

# Servomotors

## Order Catalogue



### Product ranges:

- LSN servomotors  
Stall torque: 0.26 to 60 Nm
- LST servomotors  
Stall torque: 0.1 to 115 Nm
- LSH Servomotors  
Stall torque: 0.26 to 26.3 Nm

**Order Catalogue: LSx Servomotors**

ID no.: 0814.25B.6-01

Date: 07/2014

Subject to technical change without notice.

The German version is the original of this Order Catalogue.

# Servomotors

The following double-page spread sets out the contents of the Order Catalogue.

This catalogue contains essential information on the performance capabilities of LTI synchronous servomotors. Take time to familiarise yourself with it.

# Table of contents

<b>1</b>	<b>Basic information on LTi servomotors from page ... 1-1</b>	<ul style="list-style-type: none"> <li>1.1 Selecting the right motor: LSN, LST, or LSH? ..... 1-1</li> <li>1.2 Comparison of torque characteristics ..... 1-2</li> <li>1.3 Properties of the motor types in comparison ..... 1-3</li> <li>1.4 Selection procedure ..... 1-4</li> </ul>
<b>2</b>	<b>LSN servomotor – compact and low-cost from page ... 2-1</b>	<ul style="list-style-type: none"> <li>2.1 Applications ..... 2-1</li> <li>2.2 Features of LSN servomotors ..... 2-1</li> <li>2.3 Declaration of conformity for LSN servomotors ..... 2-2</li> <li>2.4 Properties of LSN servomotors ..... 2-3</li> <li>2.5 Cooling ..... 2-3</li> <li>2.6 Order codes for the LSN series ..... 2-4</li> <li>2.7 Composition of standard version ..... 2-5</li> <li>2.8 Ordering example for LSN servomotors: ..... 2-5</li> <li>2.9 Ordering options ..... 2-5</li> <li>2.10 Encoder system options ..... 2-6</li> </ul>
<b>3</b>	<b>LST servomotor – the versatile one from page ... 3-1</b>	<ul style="list-style-type: none"> <li>3.1 Applications ..... 3-1</li> <li>3.2 Features of LST servomotors ..... 3-1</li> <li>3.3 Declaration of conformity for LST servomotors ..... 3-2</li> <li>3.4 Properties of LST servomotors ..... 3-3</li> <li>3.5 Cooling ..... 3-3</li> <li>3.6 Order codes for LST series ..... 3-4</li> <li>3.7 Composition of standard version ..... 3-5</li> <li>3.8 Ordering example for LST servomotors: ..... 3-5</li> <li>3.9 Ordering options ..... 3-5</li> <li>3.10 Encoder system options ..... 3-6</li> </ul>
<b>4</b>	<b>The LSH servomotor – the power pack from page ... 4-1</b>	<ul style="list-style-type: none"> <li>4.1 Applications ..... 4-1</li> <li>4.2 Features of LSH servomotors ..... 4-1</li> <li>4.3 Declaration of conformity for LSH servomotors ..... 4-2</li> <li>4.4 Properties of LSH servomotors ..... 4-3</li> <li>4.5 Cooling ..... 4-3</li> <li>4.6 Order codes for LSH series ..... 4-4</li> <li>4.7 Composition of standard version ..... 4-5</li> <li>4.8 Ordering example for LSH servomotors: ..... 4-5</li> <li>4.9 Ordering options ..... 4-5</li> <li>4.10 Encoder system options ..... 4-6</li> </ul>
<b>5</b>	<b>Servomotor encoders from page ... 5-1</b>	<ul style="list-style-type: none"> <li>5.1 Overview of encoder types ..... 5-1</li> </ul>
<b>6</b>	<b>Servomotor accessories from page ... 6-1</b>	<ul style="list-style-type: none"> <li>6.1 Overview of encoder and motor cables ..... 6-1</li> <li>6.2 Ready-made encoder cables ..... 6-3</li> <li>6.3 Ready-made motor cables ..... 6-5</li> </ul>
<b>7</b>	<b>Appendix from page ... 7-1</b>	<ul style="list-style-type: none"> <li>7.1 Holding brake ..... 7-1</li> </ul>



1

2.11 Typical M-n characteristic of LSN servomotors.....	2-8	2.21 Motor type: LSN-097 ( $U_{dc} = 560\text{ V}$ ).....	2-38
2.12 Permissible axial and lateral forces.....	2-9	2.22 Motor type: LSN-127 ( $U_{dc} = 560\text{ V}$ ).....	2-42
2.13 Connections.....	2-12	2.23 Motor type: LSN-158 ( $U_{dc} = 560\text{ V}$ , $n_n = 2000\text{ rpm}$ ).....	2-46
2.14 Key definitions.....	2-14	2.24 Motor type: LSN-158 ( $U_{dc} = 560\text{ V}$ , $n_n = 3000\text{ rpm}$ ).....	2-50
2.15 Overview of LSN servomotors.....	2-15	2.25 Motor type: LSN-190 ( $U_{dc} = 560\text{ V}$ , $n_n = 2000\text{ rpm}/1000\text{ rpm}$ ).....	2-54
2.16 Motor type: LSN-050 ( $U_{dc} = 320\text{ V}$ ).....	2-18	2.26 Motor type: LSN-190 ( $U_{dc} = 560\text{ V}$ , $n_n = 3000\text{ rpm}/2500\text{ rpm}$ ).....	2-58
2.17 Motor type: LSN-050 ( $U_{dc} = 560\text{ V}$ ).....	2-22		
2.18 Motor type: LSN-074 ( $U_{dc} = 320\text{ V}$ ).....	2-26		
2.19 Motor type: LSN-074 ( $U_{dc} = 560\text{ V}$ ).....	2-30		
2.20 Motor type: LSN-097 ( $U_{dc} = 320\text{ V}$ ).....	2-34		

2

3.11 Typical M-n characteristic of LST servomotors.....	3-8	3.21 Motor type: LST-097 ( $U_{dc} = 560\text{ V}$ ).....	3-34
3.12 Permissible axial and lateral forces.....	3-9	3.22 Motor type: LST-127 ( $U_{dc} = 560\text{ V}$ ).....	3-38
3.13 Connections.....	3-10	3.23 Motor type: LST-158 ( $U_{dc} = 560\text{ V}$ ).....	3-42
3.14 Key definitions.....	3-12	3.24 Motor type: LST-190 ( $U_{dc} = 560\text{ V}$ ).....	3-46
3.15 Overview of LST servomotors.....	3-13	3.25 Motor type: LST-220 ( $U_{dc} = 560\text{ V}$ ).....	3-50
3.16 Motor type: LST-037 ( $U_{dc} = 320\text{ V}$ ).....	3-14	3.26 LST servomotors for functional extra-low voltage.....	3-55
3.17 Motor type: LST-050 ( $U_{dc} = 320\text{ V}$ ).....	3-18	3.27 Motor type: LST-037 ( $U_{dc} = 24\text{ V}/48\text{ V}$ ).....	3-56
3.18 Motor type: LST-074 ( $U_{dc} = 320\text{ V}$ ).....	3-22		
3.19 Motor type: LST-074 ( $U_{dc} = 560\text{ V}$ ).....	3-26		
3.20 Motor type: LST-097 ( $U_{dc} = 320\text{ V}$ ).....	3-30		

3

4.11 Typical M-n characteristic of LSH servomotors.....	4-8	4.21 Motor type: LSH-127 ( $U_{dc} = 560\text{ V}$ ).....	4-34
4.12 Permissible axial and lateral forces.....	4-9	4.22 LSH servomotors for functional extra-low voltage.....	4-39
4.13 Connections.....	4-10	4.23 Motor type: LSH-050 ( $U_{dc} = 24\text{ V}$ ).....	4-40
4.14 Key definitions.....	4-12	4.24 Motor type: LSH-050 ( $U_{dc} = 48\text{ V}$ ).....	4-44
4.15 Overview of LSH servomotors.....	4-13	4.25 Motor type: LSH-074 ( $U_{dc} = 24\text{ V}/48\text{ V}$ ).....	4-48
4.16 Motor type: LSH-050 ( $U_{dc} = 320\text{ V}$ ).....	4-14		
4.17 Motor type: LSH-074 ( $U_{dc} = 320\text{ V}$ ).....	4-18		
4.18 Motor type: LSH-074 ( $U_{dc} = 560\text{ V}$ ).....	4-22		
4.19 Motor type: LSH-097 ( $U_{dc} = 320\text{ V}$ ).....	4-26		
4.20 Motor type: LSH-097 ( $U_{dc} = 560\text{ V}$ ).....	4-30		

4

5

6

7

Space for notes

1

A large grid of graph paper for taking notes, consisting of 20 columns and 30 rows of small squares.

6

# 1 Basic information on LTI servomotors

## 1.1 Selecting the right motor: LSN, LST, or LSH?

**Whichever variant you choose, you are sure to have picked a high-quality synchronous servomotor.**

The full range of servomotors from LTI-DRIVES features high-quality bearings and has the same unchanged flange, the same insulation system and the same encoder system. In short, the mechanism is absolutely identical and of top quality!

The LST motor differs from the LSH and LSN in the design of the stator package and the number of rotor pole pairs. While the LSH and LSN motors feature a concentrated winding, the LST relies on the conventional 6-pole stator winding with the familiar properties of a dynamic synchronous servomotor with neodymium-iron-boron magnets.

While the conventional so-called "distributed winding" provides the LST motor with a relatively large winding head, the so-called "concentrated winding" on the LSH means this feature is not needed. Especially on motors with a short panel packet, the winding head normally featured on the LST takes up half the length of the stator. This length of the stator not required for torque formation does not feature on the LSH and LSN motors. The result is a shorter motor with higher torque and up to 100 % more dynamism. Moreover, based on the savings in material and manufacturing cost we are able to offer the LSH and LSN motors as much as 20 % cheaper.

The LSN product range in turn is an enhancement of the LSH range, incorporating the Q 158 and Q 190 platforms. The winding construction is a potting compounded single pole winding. An optimised thermal design has increased the power density by a further approximately 30% compared to the LSH range. So the LSN servomotors are not only of high quality, with outstanding power density and Dynamism, they are even fit for high-end applications.

The various properties in summary:

	Preferential LSN motor types (dependent on options)	LSH motor types	LST motor types
Winding technique	Concentrated winding like H type, in one piece iron core potting compounded	Concentrated pole winding (segmented)	Conventional "distributed" winding
Structure	Rotor 10-pole (except: LSN-050 = 6-pole)	Rotor 10-pole (except: LSH-050 = 6-pole)	6-pole design
Rated frequency	up to 250 Hz at 3000 rpm (except: LSH-050 up to 225 Hz at 4500 rpm)	up to 250 Hz at 3000 rpm (except: LSH-050 up to 225 Hz at 4500 rpm)	up to 150 Hz at 3000 rpm
Smooth running	Good	Good	Very good
Sizes	LSN-050 to LSN-190	LSH-050 to LSH-127	LST-037 to LST-220

Table: LSN servomotors – preferential types, because lower-cost, technically state-of-the-art and shorter delivery lead times.

## 1.2 Comparison of torque characteristics

1

LSN-97-0750-30-320

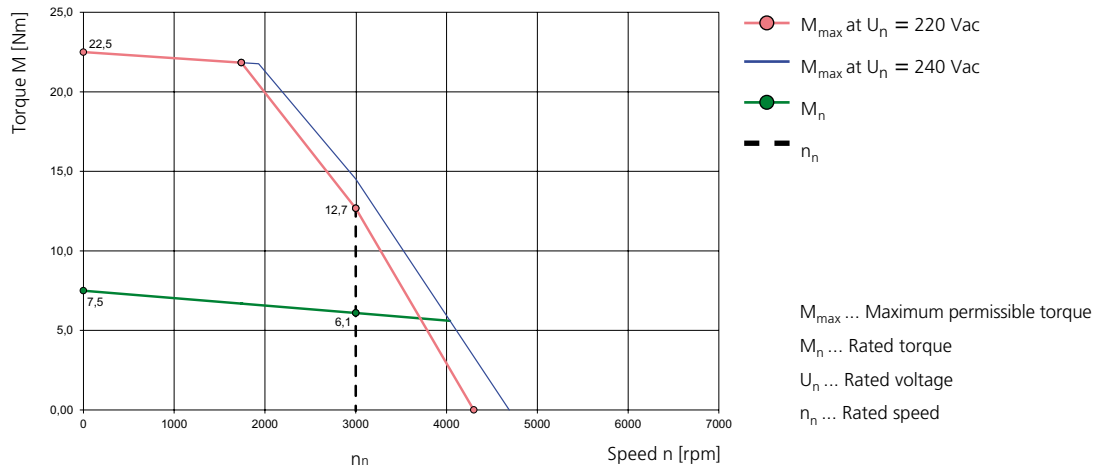

LST-97-2-30-320

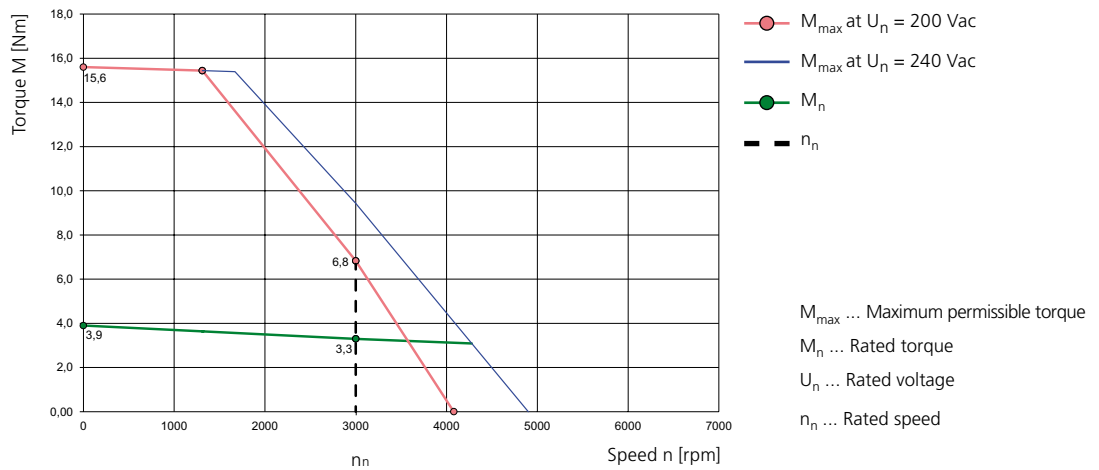

LSH-97-2-30-320

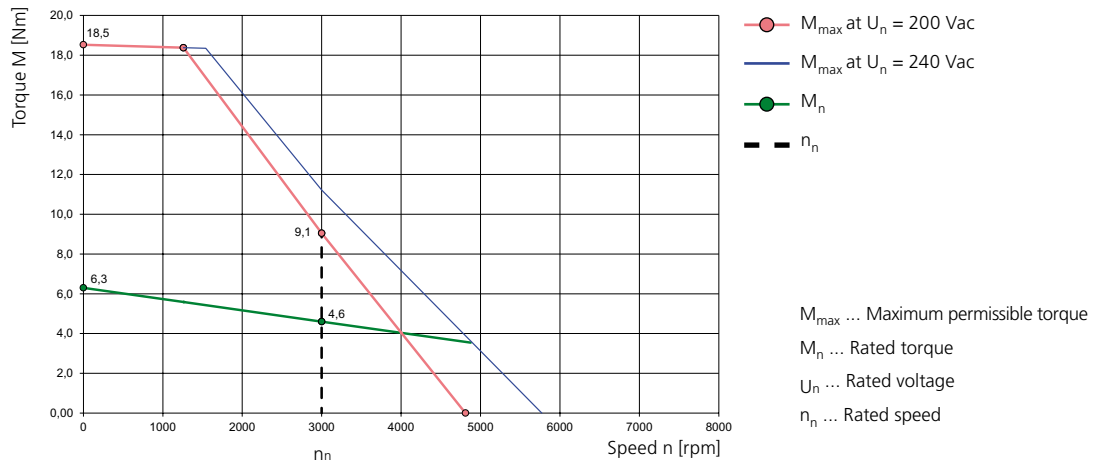



## 1.3 Properties of the motor types in comparison



The torque characteristics in the previous section and the properties set out in the following table provide valuable information which will help you choose the right motor. Also, your specific application will determine which motor type is right for you. If you are unsure, contact us. We will be glad to advise you.

Property	Servomotor		
	LSN	LSH	LST
Power density			
Dynamics			
Overload capacity			
Availability of special windings			
Suitable for Low-voltage windings			
Suitable for high stall torques			
Moment of inertia			
Suitable for high speeds			
Synchronism, cogging			
Value for money			
Wide range of encoder variants			
Wide range of size variants			
	... Top	... Good	... Standard
		... Standard	...Unsuitable

Table: Properties and suitability of servomotors

## 1.4 Selection procedure

1

Basic information		To select the correct drive and motor, you need to know the specific speed and the load cycle of the drive task at hand.
		Define the protection:IP64, IP65
		Define the supply voltage:230 V to 400 V.
		Define the platforms
		Define the maximum torque from the load cycle profile or by dimensioning via Servosoft - see c-line Drives Engineering Guide, in appendix - on our product DVD.
		Define the mean (effective) torque - see Engineering Guide.
		Define the required motor type: LSN/LST/LSH ... (page 1-3)
		Select the motor on the relevant data page in line with the following criteria: Synchronous servomotor: $n_{\max} \leq 1.1 \cdot n_{\text{rated}}$ $M_{\text{eff}} \leq M_{\text{rated}}$
		Define the required encoder system in line with requirements:resolver, absolute value encoder, pulses per revolution.
		Complete motor designation, with all required option (type code).
		Define the length of the required ready made power cable.
		Define the length of the required ready made power cable.
		Select the inverter/servocontroller for the chosen motor from the selection and ordering data based on the standard overload conditions. Select the inverter/servocontroller according to the respective motor stall current/rated current.

Space for notes

Space for notes

1

A large grid of graph paper for taking notes, consisting of 20 columns and 30 rows of small squares.

Space for notes





## 2 The LSN servomotor – compact at best price quality

### 2.1 Applications

LTI synchronous servomotors are brushless three-phase-current motors for high-end servo applications, available in all speed and voltage variants. They are particularly suitable for positioning tasks on machine tools, industrial robots, transfer lines, etc., as well as for applications entailing high dynamic and stability demands.

The standard versions of our servomotors are equipped to handle a wide range of applications. Available options include a holding brake, IP65 protection, a wide variety of temperature monitors, cable tails, high-resolution SSI encoders and Hiperface encoder, through to custom flanges and special shafts. We also optionally offer our servomotors in EX (explosion-proof) variants. Contact our drive specialists for details.

The LSN product range featuring stall torques ( $M_0$ ) from 0.28 Nm to 60 Nm (externally cooled up to 78 Nm) is an enhancement of the LSH range (section 4) incorporating the Q 158 and Q 190 platforms.

Preferential motor types available are for DC link voltages of 560 V, 320 V as well as 24 V and 48 V.

The winding construction is a potting compounded single pole winding. An optimised thermal design has increased the power density by a further approximately 30% compared to the LSH range. So the power density and dynamism of the LSN servomotors are of the highest standard.

### 2.2 Features of LSN servomotors

- Supreme power density and high dynamism
- Neodymium/iron/boron alloy (Nd-Fe-B) magnets
- Resolver (sine commutation)
- Plug-in terminals
- Good value for money
- Encapsulated winding
- UL approbation
- Various encoders available as options

## 2.3 Declaration of conformity for LSN servomotors

### EG-Konformitätserklärung



#### EC Declaration of Conformity

Der Hersteller  
*The manufacturer* LTI DRIVES GmbH  
Gewerbestraße 5-9  
35633 Lahnau

erklärt hiermit, dass die folgenden Produkte  
*declares that the following products*

Produktbezeichnung:  
*Product designation:* Synchron-Servomotor  
Synchronous Servomotor

Produkttypen:  
*Product types:* LSH, LST, LSN  
LSH, LST, LSN

den Sicherheitsbestimmungen der nachstehenden EG-Richtlinie entsprechen:  
*comply with the essential requirements of the following EC Directive:*

2006/95/EG  
2006/95/EC [Niederspannungsrichtlinie]  
[Low Voltage Directive]

und dass folgende angeführte harmonisierte Norm angewandt wurde:  
*and that the following harmonised standard has been applied:*

EN 60034-1:2004  
Drehende elektrische Maschinen - Teil 1: Bemessung und Betriebsverhalten (IEC 60034-1:2004)  
*Rotating electrical machines - Part 1: Rating and performance (IEC 60034-1:2004)*

EN 60034-5:2001+A1:2007  
Drehende elektrische Maschinen - Teil 5: Schutzarten aufgrund der Gesamtkonstruktion von drehenden elektrischen Maschinen (IP-Code) - Einteilung (IEC 60034-5:2000)  
*Rotating electrical machines - Part 5: Degrees of protection provided by the integral design of rotating electrical machines (IP code); Classification (IEC 60034-5:2000)*

EN 60034-6:1993  
Drehende elektrische Maschinen - Teil 6: Einteilung der Kühlverfahren (IC-Code) (IEC 60034-6:1991)  
*Rotating electrical machines - Part 6: Methods of cooling (IC-Code) (IEC 60034-6:1991)*

EN 60034-9:2005+A1:2007  
Drehende elektrische Maschinen - Teil 9: Geräuschgrenzwerte (IEC 60034-9:2003)  
*Rotating electrical machines - Part 9: Noise limits (IEC 60034-9:2003)*

Jahr der CE-Kennzeichnung / *Year of CE-marking:* 2005

Unterschrift / *signature*

Name / *name:*

Stellung / *position:*

Datum / *date:*

  
Dr. Josef Wiesing

Geschäftsführer / *Managing Director*

04.12.2012

Dokument: 0970.0DK.2-04

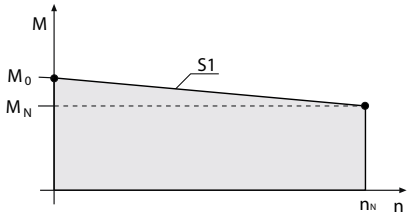

## 2.4 Properties of LSN servomotors

Machine type	Permanently excited 3-phase-current synchronous servomotor
Magnet material	Neodymium-iron-boron
Design (DIN 42948)	B5, V1, V3
Protection (DIN 40050)	IP64, IP54 to EN 60034-5 (circulating machines), IP65 optionally available
Insulating material class	Insulating material class F to VDE0530 , winding overtemperature $\Delta t = 100\text{ }^\circ\text{C}$ , ambient temperature $t_u = -20\text{ }^\circ\text{C}$ to $+40\text{ }^\circ\text{C}$ , no condensation!!!
Coating	RAL 9005 (matt black)
Shaft end on A-side	Smooth shaft (feather key and feather key way DIN 6885, tolerance band k6 as option)
Smooth running, coaxiality and axial run-out to DIN 42955	Tolerance N (normal), tolerance R (reduced) on request
Thermal motor monitoring	DIN-PTC in a stator winding (standard)
Torque load	To prevent thermal motor overloading, the effective load moment at medium RPM must not be above curve S1.
 $M_{\text{eff}} = \sqrt{\frac{S (M_n^2 \times t_n)}{t_{\text{ges}}}} \quad \bar{n} = \frac{S (n_n \times t_n)}{t_{\text{ges}}}$	
Maximum pulse torque	Typically 2 to 4 times rated torque for max. 0.2 s, depending on controller assignment
Vibration severity to ISO 2373	Grade N, optionally R
Bearing service life	The average service life under nominal conditions ( $M_{\text{max}} \leq M_N$ ) is 20,000 h
Termination mode of motor, thermistor and holding brake	via plug-in terminals
Termination mode of encoder system	Signal plug (mating plug not supplied)

## 2.5 Cooling

The specified nominal data relate to a maximum ambient temperature of  $40\text{ }^\circ\text{C}$  and mounting of the motor on an aluminium plate with a maximum temperature of  $65\text{ }^\circ\text{C}$  and installed at an altitude of max. 1,000 m above MSL.

Minimum mounting area: 2.5 x area of motor flange

Thickness of mounting area: min. 10 mm

If the motor is mounted with insulation (no heat discharge via the flange) the nominal torque must be reduced. For installations above an altitude of  $> 1000\text{ m}$  above MSL the power output must be reduced by 1 % per 100 metres. The maximum installation altitude is 4000 metres. At ambient temperatures  $> 40\text{ }^\circ\text{C}$  the power output must be reduced by 1 % per  $1^\circ\text{C}$ . The maximum ambient temperature is  $50\text{ }^\circ\text{C}$ .

## 2.6 Order codes for LTi LSN series synchronous motors



### NOTE:

Preferential types are motors and options readily available ex stock. The wide range of variants means there are many combination options. The options marked with "\*" are preferential types and can be delivered more quickly.

LSN - 074 - 0115 - 30 - 320 / D1 , B , P , X , K , S4 , G6.1S , W		Options (if available, sequence varying)	
<b>LTi synchronous motor series N</b>			
<b>Edge dimensions in mm (no flange dimensions)</b>	050 074 097 127 158 190		
<b>Stall torque</b>	0.28 Nm → <b>0028</b> 0.54 Nm → <b>0054</b> 0.75 Nm → <b>0075</b> 0.95 Nm → <b>0095</b> 1.15 Nm → <b>0115</b> 2.05 Nm → <b>0205</b> 3.50 Nm → <b>0350</b> 4.80 Nm → <b>0480</b> 5.10 Nm → <b>0510</b> 7.50 Nm → <b>0750</b> 9.60 Nm → <b>0960</b>	11.30 Nm → <b>1130</b> 12.00 Nm → <b>1200</b> 16.00 Nm → <b>1600</b> 18.00 Nm → <b>1800</b> 20.00 Nm → <b>2000</b> 24.00 Nm → <b>2400</b> 30.00 Nm → <b>3000</b> 38.00 Nm → <b>3800</b> 40.00 Nm → <b>4000</b> 44.00 Nm → <b>4400</b> 50.00 Nm → <b>5000</b> 60.00 Nm → <b>6000</b>	
<b>Rated speed (x100) in rpm</b>		30 45	
<b>DC link voltage of controller (VDC)</b>			320 560
<b>Options</b>		Thermoswitch / e.g. Klixon → <b>T0</b> (DIN-PTC double basic insulation) <b>Standard!</b> → <b>*T1</b> KTY84-130 → <b>T4</b>	
<b>Thermal protection</b>			
<b>Brake option</b>		Holding brake 24 VDC	<b>*B</b>
<b>Feather key option</b>		Feather key to DIN 6885, Sheet 1	<b>*P</b>
<b>Custom variant</b>		(e.g. special flange/shaft/housing/encoder, etc.)	<b>X</b>
<b>Cable option</b>		Cable, 1 m, open ends	<b>K</b>
<b>Termination option</b> (The A-side of the motor is the shaft face)		Angled plug, aligned to A-side Angled plug, aligned to B-side Angled plug, rotated 90° Angled/rotating plugs from size LSN-127, angled, rotating plugs with raised body, rotation angle 270°	<b>S1</b> <b>S2</b> <b>S3</b> <b>*S4</b> <b>S7</b>
<b>Options Encoder system</b> (For details see following table)		Resolver with 1 pole pair Resolver with 1 pole pair Safety Resolver with 3 pole pair Resolver with 5 pole pair Multi-turn absolute value encoder EQN 1325 Single-turn absolute value encoder ECN 1313 Single-turn absolute value encoder SRS 50 Multi-turn absolute value encoder SRM 50 Single-turn absolute value encoder SKS 36 Single-turn absolute value encoder SKS 36 Safety Multi-turn absolute value encoder SKM 36 Multi-turn absolute value encoder SKM 36 Safety Single-turn absolute value encoder SEK 37 Multi-turn absolute value encoder SEL 37 Single-turn absolute value encoder ECN 1313 Multi-turn absolute value encoder EQN 1325 Single-turn absolute value encoder ECN 1113 Multi-turn absolute value encoder EQN 1125	→ <b>*1R</b> → <b>1RY</b> → <b>3R</b> → <b>5R</b> → <b>G3</b> → <b>G5</b> → <b>G6.1S</b> → <b>G6.1M</b> → <b>G6.2S</b> → <b>G6.2SY</b> → <b>G6.2M</b> → <b>G6.2MY</b> → <b>G6.3S</b> → <b>G6.3M</b> → <b>G12.1S</b> → <b>G12.1M</b> → <b>G12.2S</b> → <b>G12.2M</b>
<b>Options Shaft packing ring</b>		Protection IP65 with shaft packing ring (approx.10mm longer) Protection IP65 without shaft packing ring	→ <b>W</b> → <b>V</b>

Table: Order codes for LSN servomotors.

The options marked with "\*" are preferential types and can be delivered more quickly.

## 2.7 Composition of standard version

- Motor shaft smooth (no feather key)
- Resolver with 1 pole pair 1R
- IP64 to DIN 40050 except flange
- IP54 to DIN VDE0530-5 / EN60034-5 (circulating machines)
- Resolver plug straight, outgoing
- Power plug straight, outgoing
- Double basic insulation (winding and PTC) T1

Table: Definition of standard version

## 2.8 Ordering example for LSN servomotors:

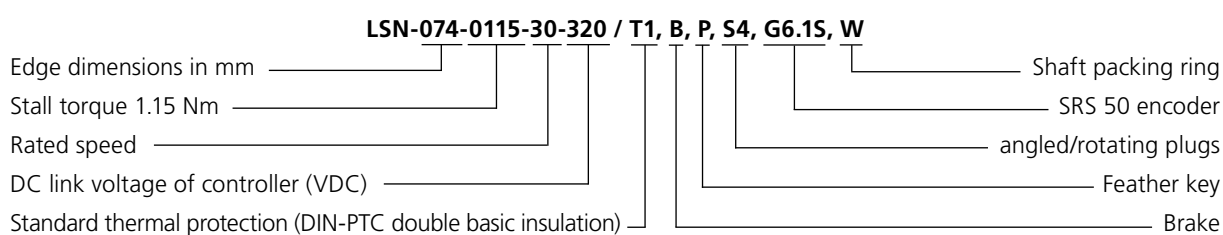

## 2.9 Ordering options

- Holding brake
- Various encoders
- Feather key to DIN 6885
- Special shaft/flange
- Special mechanism
- Servo gearing
- Cable tail
- UL approbation
- ATEX acceptance (please ask LTI-DRIVES specialist)
- etc.

## 2.10 Encoder system options



### NOTE:

Preferential types are motors and options readily available ex stock. The wide range of variants means there are many combination options. The options marked with "\*" are preferential types and can be delivered more quickly.

Ordering options	Description	Interface	Oscillations analog	Multi-turn resolution	Compatible with
*1R	Resolver with 1 pole pair	Analog	1	-	all LSN
1RY	Resolver with 1 pole pair Safety	Analog	1	-	all LSN <sup>1)</sup>
3R	Resolver with 3 pole pair	Analog	3	-	only LSN-050
5R	Resolver with 5 pole pair	Analog	5	-	from LSN-074
G3	Multi-turn absolute value encoder EQN 1325	Analog and SSI	2048	12-bit	from LSN-074
G5	Single-turn absolute value encoder ECN 1313	Analog and SSI	2048	-	from LSN-074
G6.1S	Single-turn absolute value encoder SRS 50	Analog and Hiperface	1024	-	from LSN-074
G6.1M	Multi-turn absolute value encoder SRM 50	Analog and Hiperface	1024	12-bit	from LSN-074
G6.2S	Single-turn absolute value encoder SKS 36	Analog and Hiperface	128	-	all LSN
G6.2SY	Single-turn absolute value encoder SKS 36 Safety	Analog and Hiperface	128	-	from LSN-050 <sup>1)</sup> (ServoOne safety)
G6.2M	Multi-turn absolute value encoder SKM 36	Analog and Hiperface	128	12-bit	all LSN
G6.2MY	Multi-turn absolute value encoder SKM 36Safety	Analog and Hiperface	128	12-bit	all LSN <sup>1)</sup> (ServoOne safety)
G6.3S	Single-turn absolute value encoder SEK 37	Analog and Hiperface	16	12-bit	all LSN
G6.3M	Multi-turn absolute value encoder SEL 37	Analog and Hiperface	16	12-bit	all LSN
G12.1S	Single-turn absolute value encoder ECN 1313	Analog and Endat 2.1	2048	-	from LSN-074
G12.1M	Multi-turn absolute value encoder EQN 1325	Analog and Endat 2.1	2048	12-bit	from LSN-074
G12.2S	Single-turn absolute value encoder ECN 1113	Analog and Endat 2.1	512	-	only LSN-050
G12.2M	Multi-turn absolute value encoder EQN 1125	Analog and Endat 2.1	512	12-bit	only LSN-050

Table: Explanation of encoder systems

1) Suitable for safety applications to EN 62061 and IEC 61508 and to EN ISO 13849-1

Space for notes

## 2.11 Typical M-n characteristic of LSN servomotors

The characteristic indicates how the servomotor's speed responds to increasing load.

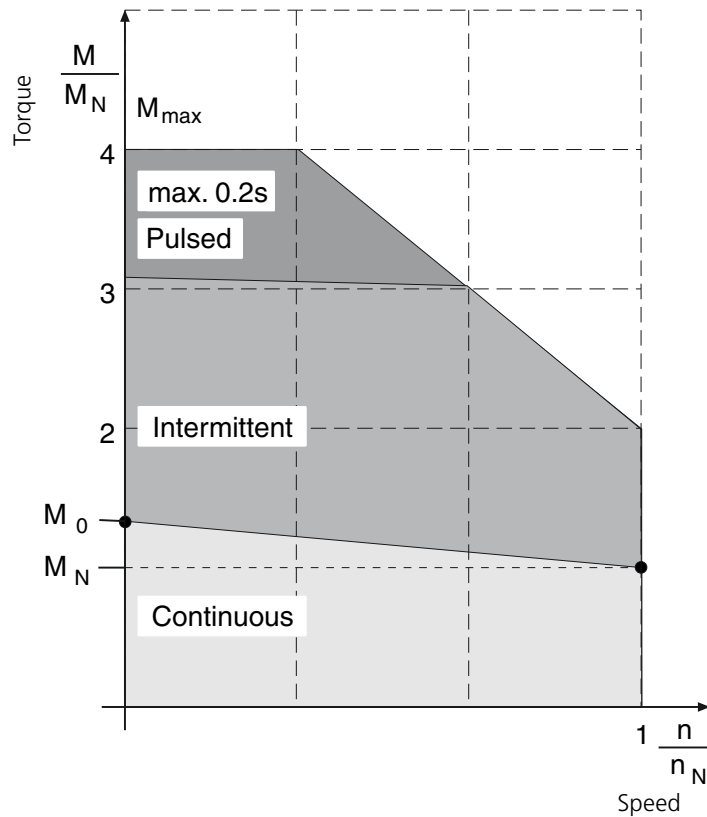

### M-n characteristic for synchronous motors

Term	Explanation
$n_N$ Rated speed	Speed at which a motor outputs the highest possible power (rated power) under full load.
$M_0$ Stall torque	Thermal limit torque of the motor at standstill. The motor can deliver this torque for an unlimited length of time.
$I_0$ Stall current	Effective value of the motor phase current required to generate the stall torque.
$M_n$ Rated torque	Thermal limit torque of the motor at rated speed $n_N$ .
$I_N$ Rated current	R.m.s. value of the motor phase current required to generate the nominal torque.
$P_N$ Rated power	Continuous power output of the motor at the nominal operation point ( $M_N, n_N$ ) at rated current $I_N$ and rated voltage $U_N$ .
$M_{MAX}, I_{MAX}$ Limit characteristic	A maximum of four times the rated current may be applied to the motors.

Table: Definition: M-n characteristic for synchronous motors

## 2.12 Permissible axial and lateral forces of LSN servomotors

### Servomotor without brake

Sizes	Radial force $F_{Rm}$ [N] at speed $n$ [rpm]					Axial force $F_{Am}$ [N] at speed $n$ [rpm]					$F_G$ [N]
	1000	2000	3000	4500	6000	1000	2000	3000	4500	6000	
LSN-050-0028	312	247	216	189	172	59	47	41	37	33	2
LSN-050-0054	338	268	234	205	186	64	51	45	39	35	2
LSN-050-0075	355	281	246	215	195	67	53	47	41	37	2
LSN-050-0095	366	291	254	222	201	70	55	48	42	38	2
LSN-074-0115	408	324	283	247	225	78	62	54	47	43	6
LSN-074-0205	472	374	327	286	260	90	71	62	54	49	6
LSN-074-0350	514	408	356	311	283	98	77	68	59	54	6
LSN-074-0480	566	449	392	343	311	108	85	75	65	59	6
LSN-097-0510	859	681	595	520	472	163	129	113	99	90	18
LSN-097-0750	942	748	653	571	519	179	142	124	108	99	18
LSN-097-0960	993	788	689	602	547	189	150	131	114	104	18
LSN-097-1130	1028	816	713	623	566	195	155	135	118	107	18
LSN-127-1200	959	761	665	581	528	182	145	126	110	100	34
LSN-127-1600	1029	817	713	623	566	196	155	136	118	108	34
LSN-127-2000	1076	854	746	652	592	204	162	142	124	113	34
LSN-127-2400	1110	881	770	672	611	211	167	146	128	116	34
LSN-158-1800	919	729	637	557	506	175	139	121	106	96	60
LSN-158-2400	986	782	684	597	543	187	149	130	113	103	60
LSN-158-3000	1034	820	717	626	569	196	156	136	119	108	60
LSN-158-3800	1069	849	741	648	588	203	161	141	123	112	60
LSN-158-4400	1097	871	761	664	604	208	165	145	126	115	60
LSN-190-3000	1752	1390	1214	1061	964	333	264	231	202	183	100
LSN-190-4000	1862	1478	1291	1128	1025	354	281	245	214	195	100
LSN-190-5000	1942	1541	1346	1176	1069	369	293	256	223	203	100
LSN-190-6000	2001	1588	1388	1212	1101	380	302	264	230	209	100

Table: Permissible axial and lateral forces of LSN servomotors up to a life of 20,000 h.  $F_G$  ... Force due to weight of rotor.

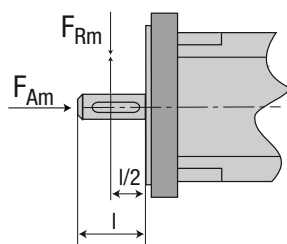

The table indicates the max. permissible lateral force  $F_{Rm}$  at the point of application  $l/2$  and the maximum permissible axial force  $F_{Am}$  for a service life of 20,000 h. A lateral force not applied in the middle of the shaft end can simply be translated to allow for the changed lever ratios.

Either the permissible radial force or the axial force may act on the motor shaft!

## Servomotor with brake

Sizes	Radial force $F_{Rm}$ [N] at speed $n$ [rpm]					Axial force $F_{Am}$ [N] at speed $n$ [rpm]					$F_G$ [N]
	1000	2000	3000	4500	6000	1000	2000	3000	4500	6000	
LSN-050-0028	356	283	247	216	196	68	54	47	41	37	2
LSN-050-0054	367	291	254	222	202	70	55	48	42	38	2
LSN-050-0075	374	297	260	227	206	71	56	49	43	39	2
LSN-050-0095	380	302	264	230	209	72	57	50	44	40	2
LSN-074-0115	431	342	299	261	237	82	65	57	50	45	6
LSN-074-0205	484	384	335	293	266	92	73	64	56	51	6
LSN-074-0350	520	413	360	315	286	99	78	68	60	54	6
LSN-074-0480	567	450	393	343	312	108	86	75	65	59	6
LSN-097-0510	881	699	611	534	485	167	133	116	101	92	18
LSN-097-0750	951	755	660	576	524	181	143	125	109	99	18
LSN-097-0960	997	791	691	604	548	189	150	131	115	104	18
LSN-097-1130	1028	816	713	623	566	195	155	135	118	108	18
LSN-127-1200	982	779	681	595	540	187	148	129	113	103	34
LSN-127-1600	1044	829	724	632	575	198	157	138	120	109	34
LSN-127-2000	1087	863	754	658	598	207	164	143	125	114	34
LSN-127-2400	1118	888	775	677	615	212	169	147	129	117	34
LSN-158-1800	1008	800	699	610	555	191	152	133	116	105	60
LSN-158-2400	1035	822	718	627	570	197	156	136	119	108	60
LSN-158-3000	1057	839	733	640	582	201	159	139	122	111	60
LSN-158-3800	1075	853	745	651	591	204	162	142	124	112	60
LSN-158-4400	1089	864	755	660	599	207	164	143	125	114	60
LSN-190-3000	1936	1537	1342	1173	1065	368	292	255	223	202	100
LSN-190-4000	1997	1585	1384	1209	1099	379	301	263	230	209	100
LSN-190-5000	2044	1622	1417	1238	1125	388	308	269	235	214	100
LSN-190-6000	2082	1652	1443	1261	1146	396	314	274	240	218	100

Table: Permissible axial and lateral forces of LSN servomotors up to a life of 20,000 h.  $F_G$  ... Force due to weight of rotor.

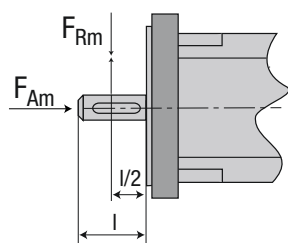

The table indicates the max. permissible lateral force  $F_{Rm}$  at the point of application  $l/2$  and the maximum permissible axial force  $F_{Am}$  for a service life of 20,000 h. A lateral force not applied in the middle of the shaft end can simply be translated to allow for the changed lever ratios.

Either the permissible radial force or the axial force may act on the motor shaft!



## Technical data – design

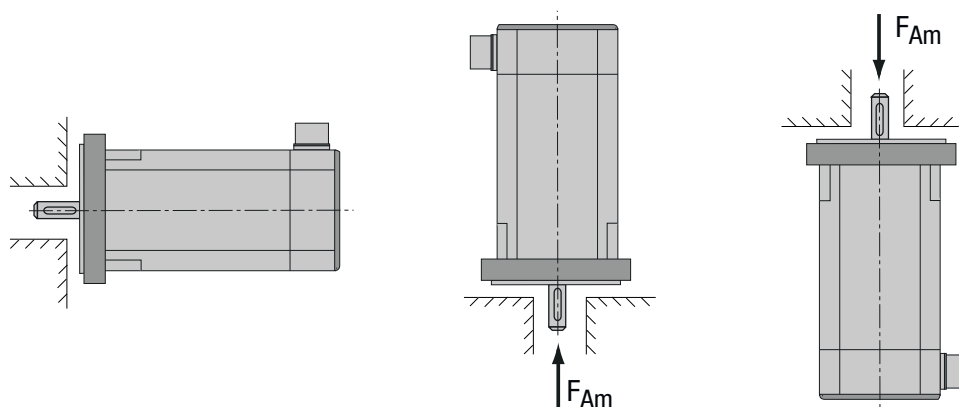

Design	B5	V1	V3
Shaft	Free shaft end	Free shaft end at bottom	Free shaft end at top
Attachment	Flange mounting Access from housing side	Flange mounting at bottom Access from housing side	Flange mounting at top Access from housing side



**NOTE:** With vertical mounting (V1) the permissible axial forces ( $F_A$ ) apply. With vertical upward mounting (V3) the permissible axial forces are reduced by the force due to weight of the rotor ( $F_G$ ).

## 2.13 Connections



LST-074-0115-30-320/S4\*, G6.1\*

Plug alignment ————┐

Plug configuration ————┘

\*Example

Standard version

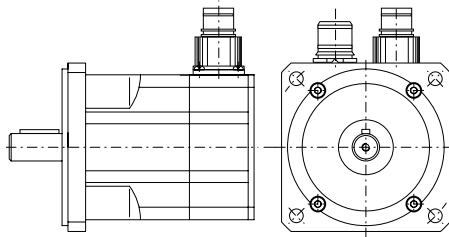

Straight plug

Version S4

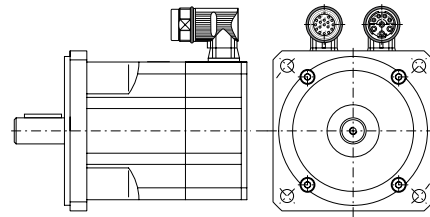

Angled/rotating plug

Version S7

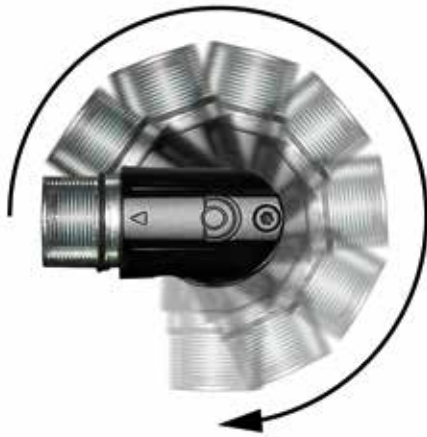

Angled plug rotating 270°

As from size LSN-127, raised bodies are used for angled, rotating plugs with a rotation angle of 270°.

## Encoder connections

### Encoder connection xR (resolver)

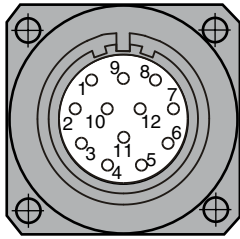

12-pin socket Junction box  
Contact pins Ø 1 mm

Pin	term	term
1	Cos +	(S1)
2	COS-	(S3)
3	SIN+	(S2)
4	SIN-	(S4)
6	REF+	(R1)
7	REF-	(R2)
11	PTC+	Motor PTC
12	PTC-	Motor PTC
5, 8, 9, 10	n. c.	Not used

Table: Encoder connection xR (resolver)

### Encoder connection Gx (optical encoder)

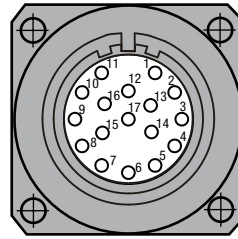

17-pin socket Junction box  
Contact pins Ø 1 mm

Pin	term G3, G5, G12.x	term G6.x
1	A+	A+
2	A-	A-
3	B+	B+
4	B -	B -
7	GND / 0V	GND / 0V
8	VCC +5 V/150 mA	-
9	-	VCC 7-12V/100mA
10	DATA+	DATA+
11	DATA-	DATA-
12	CLK+	-
13	CLK-	-
16	VCC-Sense	-
17	GND-Sense	-
5, 6, 14, 15	n. c.	n. c.

Table: Encoder connection Gx (optical encoder)

## Power connections

### Power connection

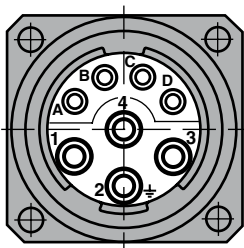

8-pin socket Junction box  
Contact pins  
for contact 1 ... 4 Ø 2 mm  
for contact A ... D Ø 1 mm

Pin	Des.	Designation
1	U	Motor phase U
2	PE	PE
3	W	Motor phase W
4	V	Motor phase V
A	Brake +	Brake+
B	Brake -	Brake -
C	PTC+	Motor PTC <sup>1)</sup>
D	PTC-	Motor PTC <sup>1)</sup>

<sup>1)</sup> For motors with resolver, not assigned

Table: Power connection of LST servomotors

## 2.14 Key definitions

<b>Stall torque <math>M_0</math> [Nm]</b>	The stall torque can be outputted for an unlimited time at speed $n=0$ rpm and under nominal ambient conditions.
<b>Rated torque <math>M_n</math> [Nm]</b>	The rated torque is outputted when the motor is drawing rated current at rated speed. The rated torque can be outputted for an unlimited time at rated speed in continuous operation.
<b>Stall current <math>I_0</math> [A]</b>	The stall current is the sine-effective current value which the motor draws at standstill in order to output the stall torque.
<b>Rated current <math>I_n</math> [A]</b>	The rated current is the sine-effective current value which the motor draws at rated speed in order to output the rated torque.
<b>Maximum permissible current (peak current) <math>I_{max}</math> [A]</b>	The peak current (sine-effective value) should not be more than 4 times the rated current. The actual value is determined by the peak current of the inverter being used.
<b>Torque constant <math>K_T</math> [Nm/A]</b>	The torque constant indicates how much torque in Nm the motor generates with 1A sine-effective current. The equation is $M=I \times K_T$
<b>Voltage constant <math>K_E</math> [V/1000 rpm]</b>	The voltage constant indicates the induced motor EMF as a sine peak value between two terminals, referred to 1000 rpm.
<b>Moment of inertia of rotor <math>J</math> [kgcm<sup>2</sup>]</b>	The constant $J$ is a measure of the mass inertia of the motor.
<b>Thermal time constant <math>T_{th}</math> [min]</b>	The constant $T_{th}$ indicates the warm-up time of the cold motor under $I_0$ load until $0.63 \times 105$ Kelvin overtemperature is reached. Under peak current the warm-up time is much shorter.
<b>Rated speed <math>n_n</math> [rpm]</b>	The rated speed is the speed at which a servomotor outputs the highest possible power – the so-called rated power – under full load.

Table: Key definitions

## 2.15 Overview of LSN servomotors



2

### Technical data

Motor type	Motor type/ Rating plate	DC link voltage $U_{dc}$ [V]	Stall torque $M_0$ [Nm]	Rated torque $M_n$ [Nm]	Rated current $I_n$ [A]	Rated speed $n_n$ [rpm]
LSN-050	LSN-050-0028-45-320	320	0.28	0.25	0.96	4500
	LSN-050-0054-45-320		0.54	0.48	1.12	4500
	LSN-050-0075-45-320		0.75	0.68	1.48	4500
	LSN-050-0095-45-320		0.95	0.85	1.70	4500
	LSN-050-0028-45-560	560	0.28	0.25	0.96	4500
	LSN-050-0054-45-560		0.54	0.48	0.90	4500
	LSN-050-0075-45-560		0.75	0.68	0.83	4500
	LSN-050-0095-45-560		0.95	0.85	1.07	4500
LSN-074	LSN-074-0115-30-320	320	1.15	1.13	2.30	3000
	LSN-074-0205-30-320		2.05	1.90	3.10	3000
	LSN-074-0350-30-320		3.50	3.00	4.30	3000
	LSN-074-0480-30-320		4.80	3.70	4.50	3000
	LSN-074-0115-30-560	560	1.15	1.13	1.30	3000
	LSN-074-0205-30-560		2.05	1.90	1.70	3000
	LSN-074-0350-30-560		3.50	3.00	2.40	3000
	LSN-074-0480-30-560		4.80	3.70	2.60	3000
LSN-097	LSN-097-0510-30-320	320	5.10	4.20	7.00	3000
	LSN-097-0750-30-320		7.50	6.10	8.80	3000
	LSN-097-0960-30-320		9.60	7.70	10.80	3000
	LSN-097-1130-30-320		11.30	8.80	10.70	3000
	LSN-097-0510-30-560	560	5.10	4.20	3.90	3000
	LSN-097-0750-30-560		7.50	6.10	5.10	3000
	LSN-097-0960-30-560		9.60	7.70	6.00	3000
	LSN-097-1130-30-560		11.30	8.80	6.90	3000

Table: Technical data of the LSN servomotor series - all values with a tolerance of  $\pm 5\%$

Motor type	Motor type/ Rating plate	DC link voltage $U_{dc}$ [V]	Stall torque $M_0$ [Nm]	Rated torque $M_n$ [Nm]	Rated current $I_n$ [A]	Rated speed $n_n$ [rpm]
LSN-127	LSN-127-1200-30-560	560	12.00	10.50	8.30	3000
	LSN-127-1600-30-560		16.00	13.80	9.90	3000
	LSN-127-2000-30-560		20.00	16.00	11.50	3000
	LSN-127-2400-30-560		24.00	20.00	14.10	3000
LSN-158	LSN-158-1800-20-560	560	18.00	14.80	8.60	2000
	LSN-158-2400-20-560		24.00	20.00	10.70	2000
	LSN-158-3000-20-560		30.00	25.30	12.90	2000
	LSN-158-3800-20-560		38.00	29.00	15.00	2000
	LSN-158-4400-20-560		44.00	36.50	17.30	2000
	LSN-158-1800-30-560	560	18.00	13.00	11.00	3000
	LSN-158-2400-30-560		24.00	17.00	13.80	3000
	LSN-158-3000-30-560		30.00	21.00	16.20	3000
	LSN-158-3800-30-560		38.00	25.00	19.70	3000
	LSN-158-4400-30-560		44.00	30.00	24.40	3000
LSN-190	LSN-190-3000-20-560	560	30.00	26.10	13.20	2000
	LSN-190-4000-20-560		40.00	32.80	15.40	2000
	LSN-190-5000-20-560		50.00	40.40	21.80	2000
	LSN-190-6000-10-560		60.00	54.00	14.60	1000
	LSN-190-3000-30-560	560	30.00	23.00	15.50	3000
	LSN-190-4000-30-560		40.00	25.00	20.10	3000
	LSN-190-5000-30-560		50.00	30.00	24.40	3000
	LSN-190-6000-25-560		60.00	36.20	20.70	2500

Table: Technical data of the LSN servomotor series - all values with a tolerance of  $\pm 5\%$

Space for notes

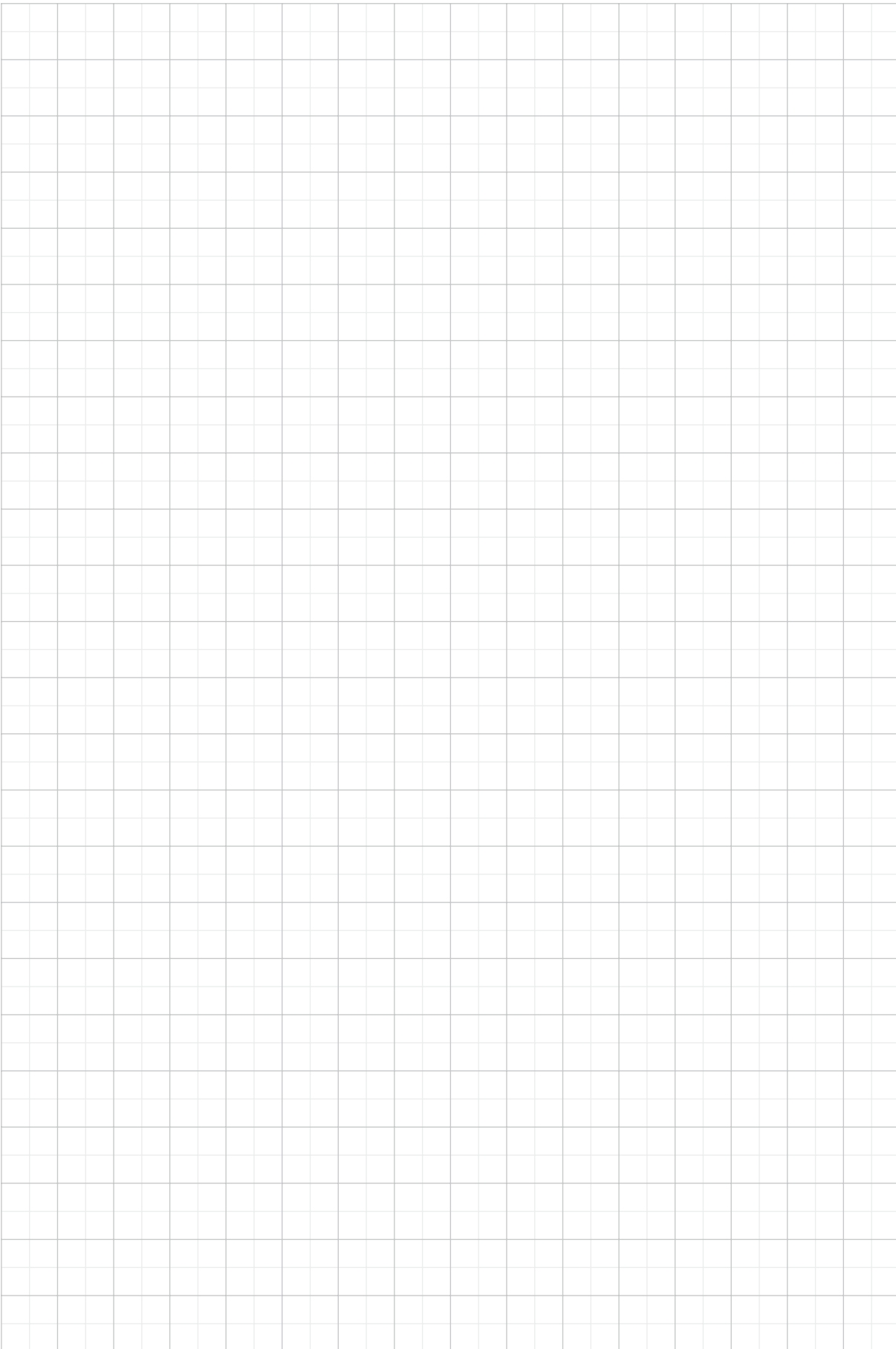
A large rectangular grid of small squares, intended for taking notes. The grid is composed of 20 columns and 30 rows of squares.

## 2.16 Motor type: LSN-050 ( $U_{dc} = 320\text{ V}$ )



2

### 2.16.1 Dimensional sketch and technical data

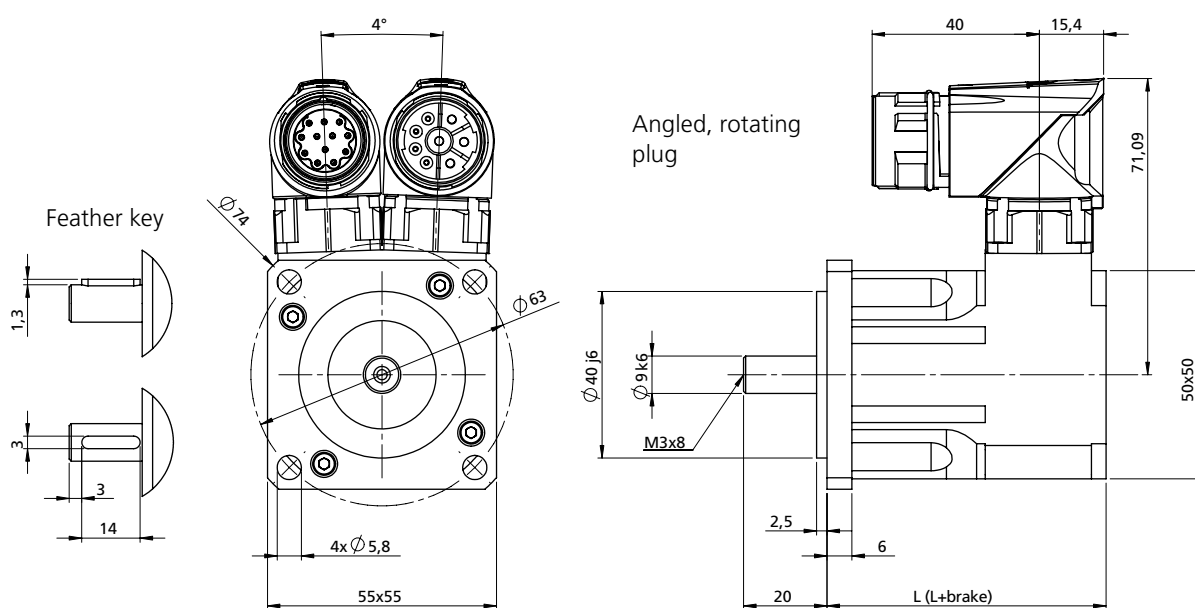

Motor type	L with resolver xR [mm]	L+brake with resolver xR [mm]	L with opt. encoder G12.xy [mm]	L+brake with opt. encoder G12.xy [mm]
LSN-050-0028	67	105	121	159
LSN-050-0054	82	120	136	174
LSN-050-0075	97	135	151	189
LSN-050-0095	112	150	166	204

Motor type	L with opt. encoder G6.1x [mm]	L+brake with opt. encoder G6.1x [mm]	L with opt. encoder G6.2x [mm]	L+brake with opt. encoder G6.2x [mm]	L with opt. encoder G6.3x [mm]	L+brake with opt. encoder G6.3x [mm]
LSN-050-0028	In preparation	In preparation	94	128	82	In preparation
LSN-050-0054	In preparation	In preparation	109	143	97	In preparation
LSN-050-0075	In preparation	In preparation	124	158	112	In preparation
LSN-050-0095	In preparation	In preparation	139	173	127	In preparation

Table: Overview of motor lengths – for overview of encoder types see section 5.1



Technical data <sup>1)</sup>	Symbol	LSN-050-0028	LSN-050-0054	LSN-050-0075	LSN-050-0095
Rated speed	$n_n$	4500 rpm	4500 rpm	4500 rpm	4500 rpm
Rated frequency	$f_N$	225 Hz	225 Hz	225 Hz	225 Hz
DC link voltage (controller)	$U_{dc}$	320 V	320 V	320 V	320 V
Rated voltage	$U_n$	220 V	220 V	220 V	220 V
Rated torque	$M_n$	0.25 Nm	0.48 Nm	0.68 Nm	0.85 Nm
Rated current	$I_n$	0.96 A	1.12 A	1.48 A	1.70 A
Rated power	$P$	0.12 kW	0.23 kW	0.32 kW	0.40 kW
Stall torque	$M_0$	0.28 Nm	0.54 Nm	0.75 Nm	0.95 Nm
Stall current	$I_0$	0.97 A	1.17 A	1.54 A	1.82 A
Maximum permissible torque	$M_{max}$	1.1 Nm	2.2 Nm	3.0 Nm	3.8 Nm
Maximum permissible current	$I_{max}$	4.5 A	5.4 A	7.1 A	8.4 A
Maximum permissible speed	$n_{max}$	12000 rpm	12000 rpm	12000 rpm	12000 rpm
Voltage constant	$K_E$	17.5 V/1000 rpm	28.0 V/1000 rpm	29.5 V/1000 rpm	31.5 V/1000 rpm
Torque constant	$K_T$	0.29 Nm/A	0.46 Nm/A	0.49 Nm/A	0.52 Nm/A
Winding resistance (2 phases)	$R_{2ph}$	28.30 $\Omega$	25.90 $\Omega$	17.00 $\Omega$	13.10 $\Omega$
Winding inductance (2 phases)	$L_{2ph}$	28.40 mH	32.30 mH	22.70 mH	19.00 mH
No load speed	$n_0$	12260 rpm	7740 rpm	7380 rpm	6950 rpm
Electrical time constant	$T_{el}$	1.0 ms	1.2 ms	1.3 ms	1.45 ms
Thermal time constant	$T_{th}$	10 min.	12 min.	15 min.	18 min.
Moment of inertia of the motor	$J$	0.000005 kgm <sup>2</sup>	0.000007 kgm <sup>2</sup>	0.000009 kgm <sup>2</sup>	0.000011 kgm <sup>2</sup>
Mass	$m$	0.76 kg	0.93 kg	1.1 kg	1.27 kg

#### Brake (optional)

Rated voltage	$U_N$	24 V $\pm$ 10 %
Rated current at 20 °C for venting	$I_N$	0.46 A
Permissible maximum speed	$n_{max}$	10000 rpm
Permissible friction energy	$W_R$	0.41 x 10 <sup>6</sup> Ws
Mass moment of inertia	$J_B$	0.0000068 kgm <sup>2</sup>
Mass	$m$	0.2 kg
Braking torque	$M_H$	2.00 Nm

#### Additional technical data

Protection	IP64, optionally IP65 or IP67
Electrical connections	Intercontec plug (x2)
Thermal motor protection	PTC, optionally thermoswitch 140° C, KTY or NTC
Nominal data	to EN 60034-1, $T_A = 40^\circ\text{C}$ , $T_{over} = 110\text{K}$ , flange temperature $\leq 65^\circ\text{C}$
Servo amplifier	Stator windings for DC link voltage $U_{dc} = 320\text{V}$ or 560 VDC, other voltages optional
Flange/shaft	to DIN 42955 N, optionally R

1) All values with a tolerance of  $\pm 10\%$ . Other windings/rated speeds possible. Subject to technical change without notice.

## 2.16.2 Characteristics

Explanations of characteristics:

The characteristic  $M_{\max}$  describes the maximum possible short-time torque at corresponding speed. It is important for dynamic processes.

The characteristic  $M_n$  indicates the thermally permissible rated torque.

The characteristics are limited by the respective maximum permissible speed  $n_{\max}$  (for  $n_{\max}$  refer to the "Technical data" table).

2

### LSN-050-0028-45-320

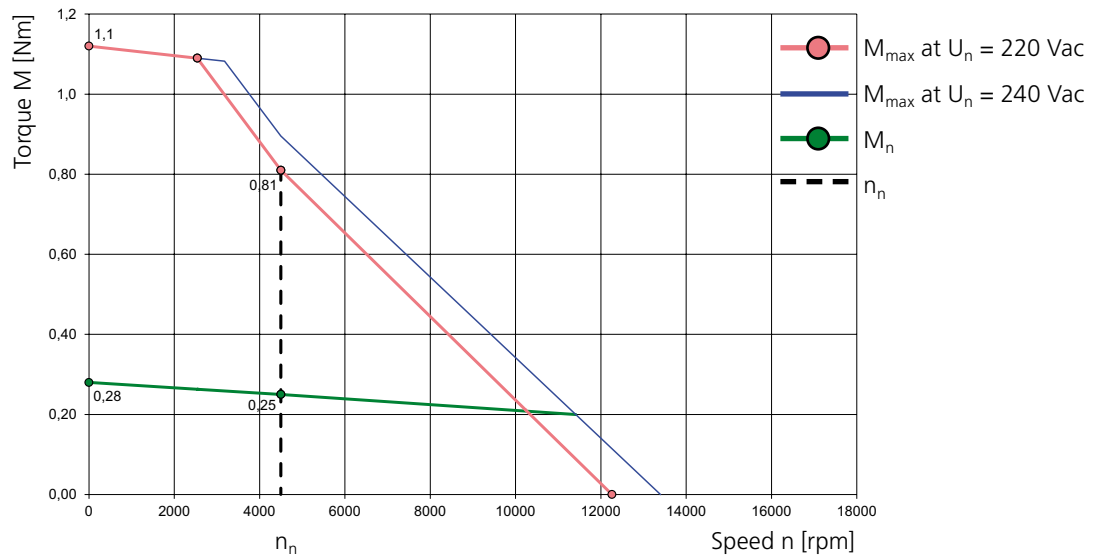

### LSN-050-0054-45-320

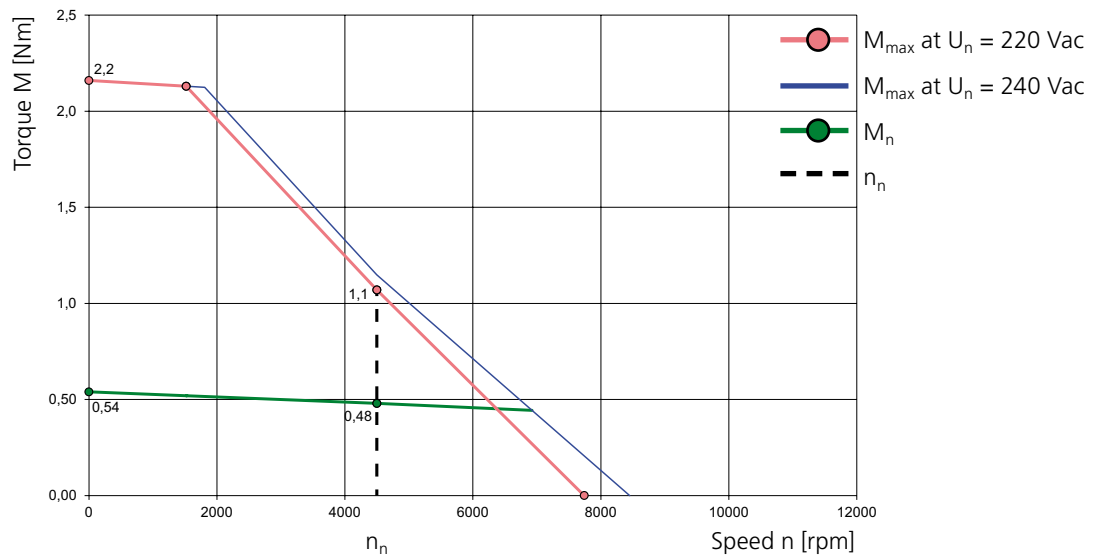

### LSN-050-0075-45-320

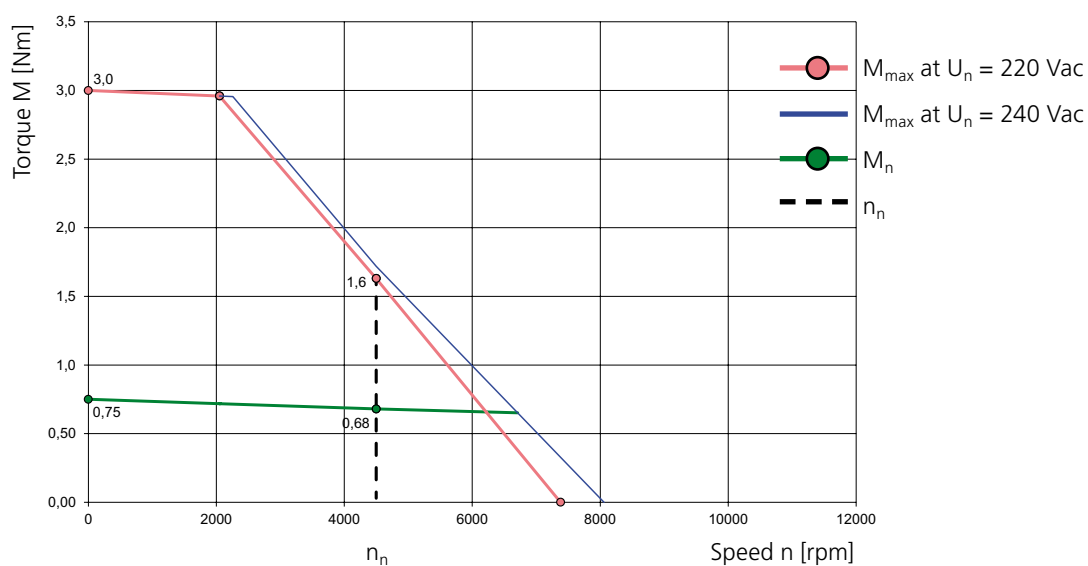

### LSN-050-0095-45-320

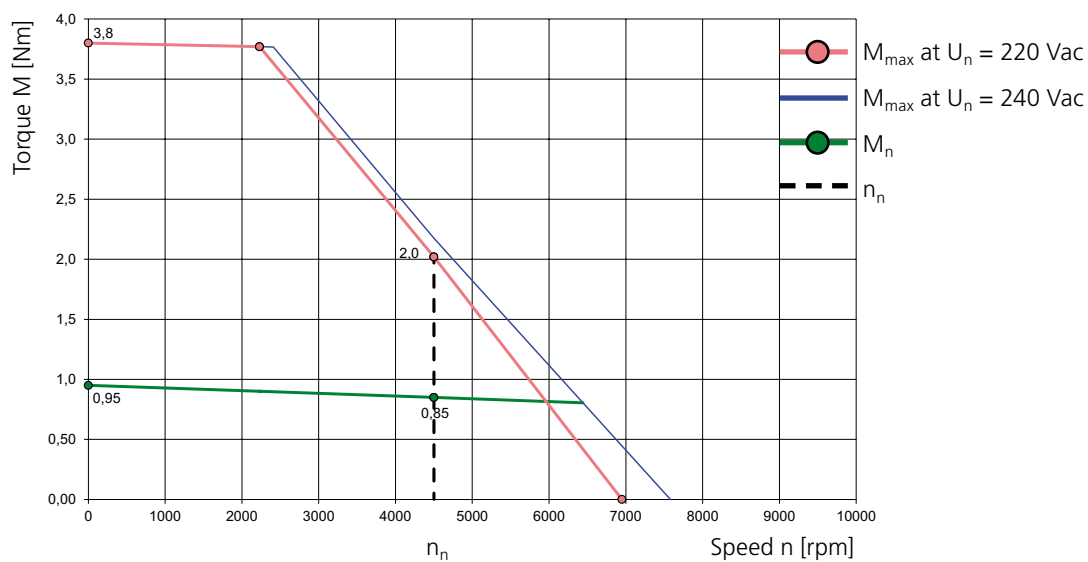

## 2.17 Motor type: LSN-050 ( $U_{dc} = 560 \text{ V}$ )



2

### 2.17.1 Dimensional sketch and technical data

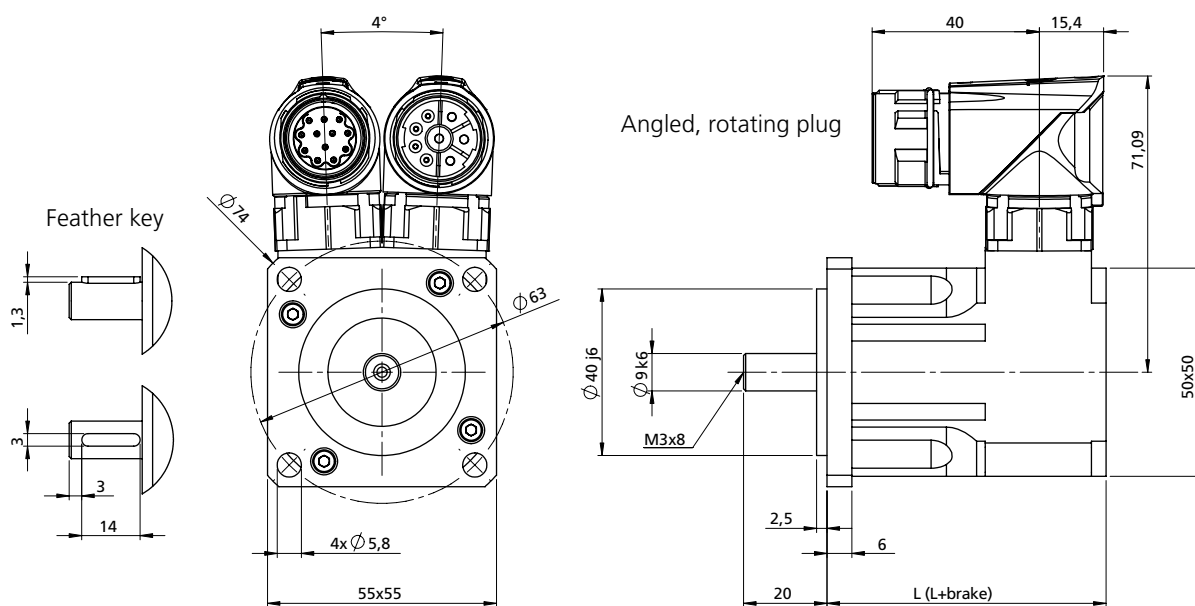

Motor type	L with resolver xR [mm]	L+brake with resolver xR [mm]	L with opt. encoder G12.xy [mm]	L+brake with opt. encoder G12.xy [mm]
LSN-050-0028	67	105	121	159
LSN-050-0054	82	120	136	174
LSN-050-0075	97	135	151	189
LSN-050-0095	112	150	166	204

Motor type	L with opt. encoder G6.1x [mm]	L+brake with opt. encoder G6.1x [mm]	L with opt. encoder G6.2x [mm]	L+brake with opt. encoder G6.2x [mm]	L with opt. encoder G6.3x [mm]	L+brake with opt. encoder G6.3x [mm]
LSN-050-0028	In preparation	In preparation	94	128	82	In preparation
LSN-050-0054	In preparation	In preparation	109	143	97	In preparation
LSN-050-0075	In preparation	In preparation	124	158	112	In preparation
LSN-050-0095	In preparation	In preparation	139	173	127	In preparation

Table: Overview of motor lengths – for overview of encoder types see section 5.1

Technical data <sup>1)</sup>	Symbol	LSN-050-0028	LSN-050-0054	LSN-050-0075	LSN-050-0095
Rated speed	$n_n$	4500 rpm	4500 rpm	4500 rpm	4500 rpm
Rated frequency	$f_N$	225 Hz	225 Hz	225 Hz	225 Hz
DC link voltage (controller)	$U_{dc}$	560 V	560 V	560 V	560 V
Rated voltage	$U_n$	380 V	380 V	380 V	380 V
Rated torque	$M_n$	0.25 Nm	0.48 Nm	0.68 Nm	0.85 Nm
Rated current	$I_n$	0.96 A	0.90 A	0.83 A	1.07 A
Rated power	$P$	0.12 kW	0.23 kW	0.32 kW	0.40 kW
Stall torque	$M_0$	0.28 Nm	0.54 Nm	0.75 Nm	0.95 Nm
Stall current	$I_0$	0.97 A	0.93 A	0.86 A	1.15 A
Maximum permissible torque	$M_{max}$	1.1 Nm	2.2 Nm	3.0 Nm	3.8 Nm
Maximum permissible current	$I_{max}$	4.5 A	4.3 A	3.9 A	5.3 A
Maximum permissible speed	$n_{max}$	12000 rpm	12000 rpm	12000 rpm	12000 rpm
Voltage constant	$K_E$	17.5 V/1000 rpm	35.0 V/1000 rpm	53.0 V/1000 rpm	50.0 V/1000 rpm
Torque constant	$K_T$	0.29 Nm/A	0.58 Nm/A	0.88 Nm/	0.83 Nm/A
Winding resistance (2 phases)	$R_{2ph}$	28.30 $\Omega$	41.10 $\Omega$	54.00 $\Omega$	33.60 $\Omega$
Winding inductance (2 phases)	$L_{2ph}$	28.40 mH	51.00 mH	72.00 mH	48.50 mH
No load speed	$n_0$	21170 rpm	10710 rpm	7100 rpm	7560 rpm
Electrical time constant	$T_{el}$	1.0 ms	1.2 ms	1.3 ms	1.45 ms
Thermal time constant	$T_{th}$	10 min.	12 min.	15 min.	18 min.
Moment of inertia of the motor	$J$	0.000005 kgm <sup>2</sup>	0.000007 kgm <sup>2</sup>	0.000009 kgm <sup>2</sup>	0.000011 kgm <sup>2</sup>
Mass	$m$	0.76 kg	0.93 kg	1.1 kg	1.27 kg

#### Brake (optional)

Rated voltage	$U_N$	24 V $\pm$ 10 %
Rated current at 20 °C for venting	$I_N$	0.46 A
Permissible maximum speed	$n_{max}$	10000 rpm
Permissible friction energy	$W_R$	0.41 x 10 <sup>6</sup> Ws
Mass moment of inertia	$J_B$	0.0000068 kgm <sup>2</sup>
Mass	$m$	0.2 kg
Braking torque	$M_H$	2.00 Nm

#### Additional technical data

Protection	IP64, optionally IP65 or IP67
Electrical connections	Intercontec plug (x2)
Thermal motor protection	PTC, optionally thermoswitch 140° C, KTY or NTC
Nominal data	to EN 60034-1, $T_A = 40^\circ \text{C}$ , $T_{over} = 110 \text{K}$ , flange temperature $\leq 65^\circ \text{C}$
Servo amplifier	Stator windings for DC link voltage $U_{dc} = 320 \text{V}$ or 560 VDC, other voltages optional
Flange/shaft	to DIN 42955 N, optionally R

<sup>1)</sup> All values with a tolerance of  $\pm 10\%$ . Other windings/rated speeds possible. Subject to technical change without notice.

## 2.17.2 Characteristics

Explanations of characteristics:

The characteristic  $M_{max}$  describes the maximum possible short-time torque at corresponding speed. It is important for dynamic processes.

The characteristic  $M_n$  indicates the thermally permissible rated torque.

The characteristics are limited by the respective maximum permissible speed  $n_{max}$  (for  $n_{max}$  refer to the "Technical data" table).

2

### LSN-050-0028-45-560

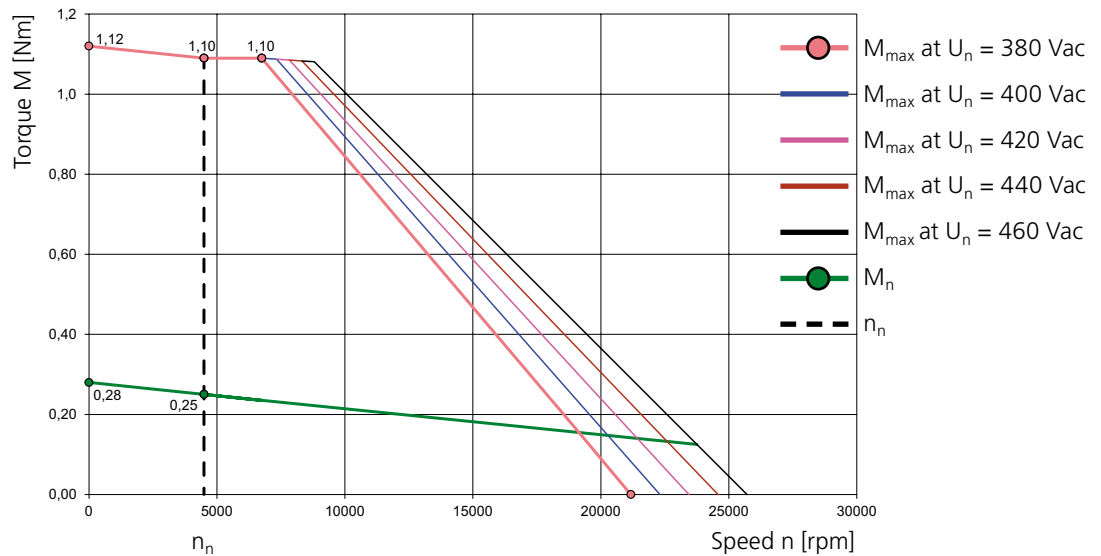

### LSN-050-0054-45-560

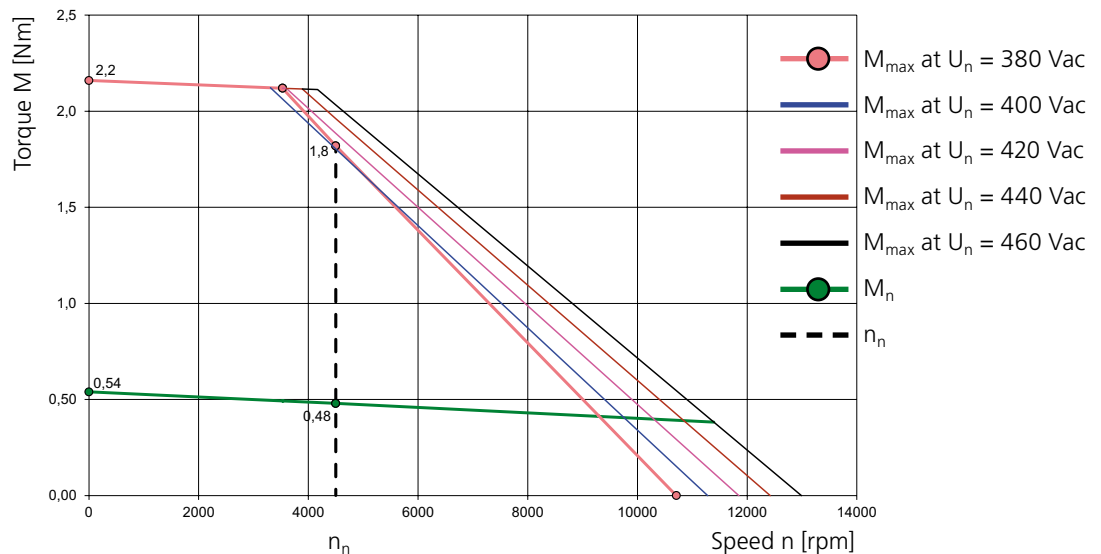

**LSN-050-0075-45-560**

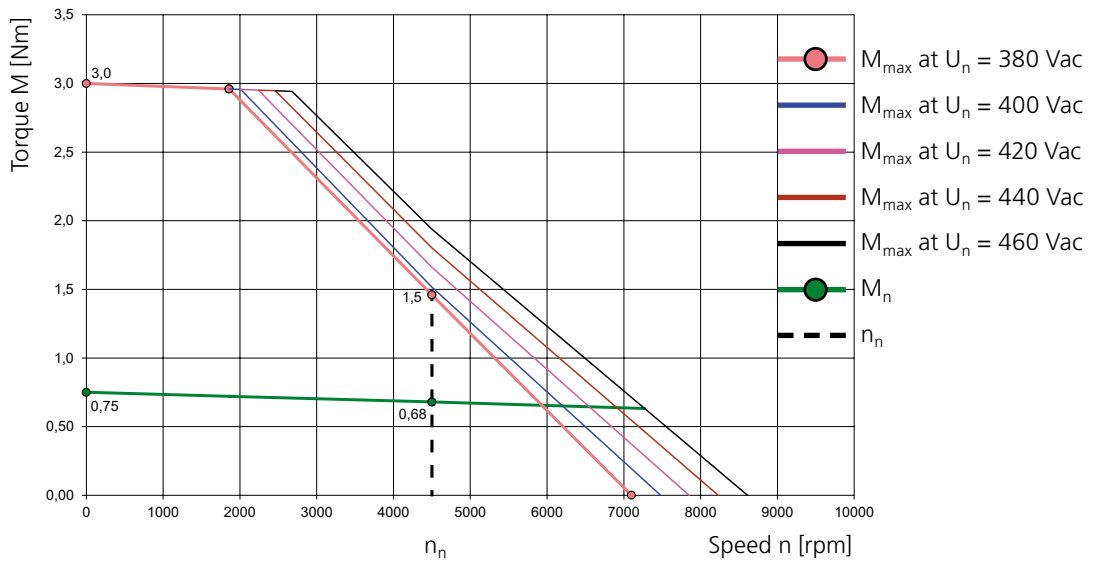

**LSN-050-0095-45-560**

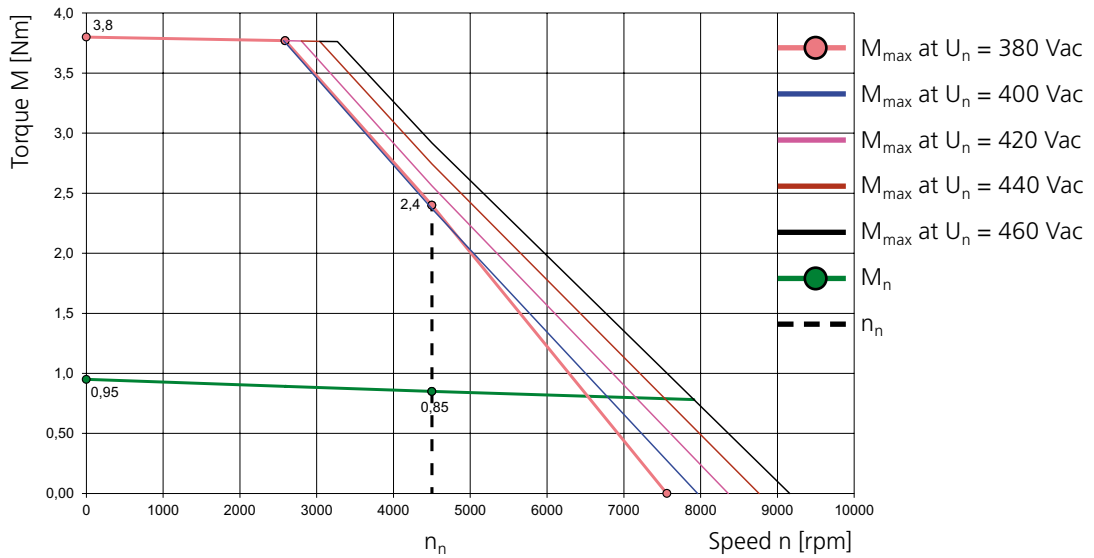

## 2.18 Motor type: LSN-074 ( $U_{dc} = 320\text{ V}$ )



### 2.18.1 Dimensional sketch and technical data

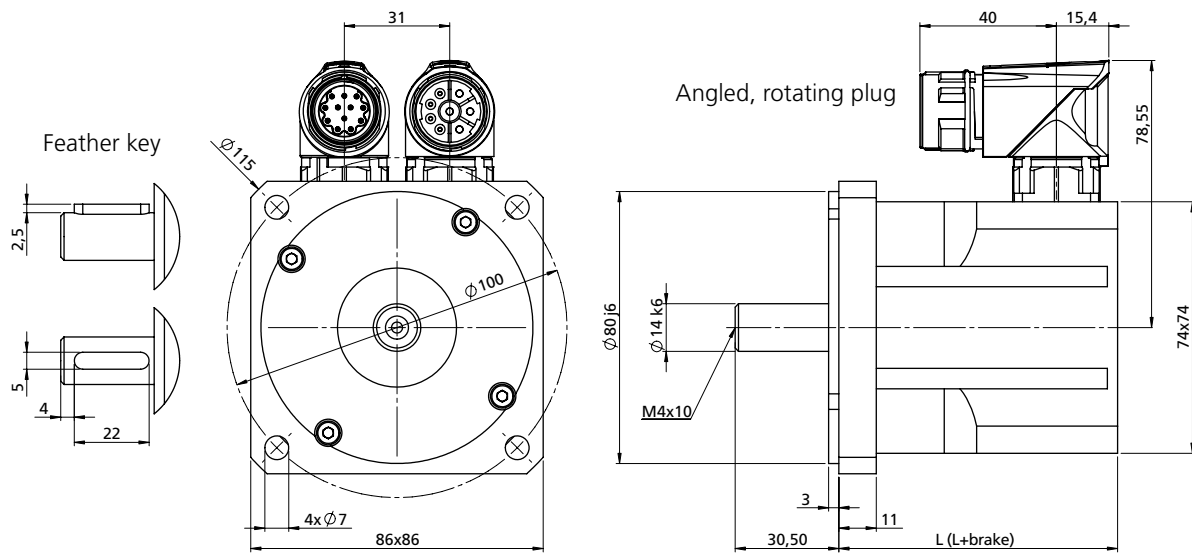

Motor type	L with resolver xR [mm]	L+brake with resolver xR [mm]	L with opt. encoder G12.xy [mm]	L+brake with opt. encoder G12.xy [mm]
LSN-074-0115	82	120	123	165.5
LSN-074-0205	100	138	141	183.5
LSN-074-0350	136	174	177	219.5
LSN-074-0480	172	210	213	In preparation

Motor type	L with opt. encoder G6.1x [mm]	L+brake with opt. encoder G6.1x [mm]	L with opt. encoder G6.2x [mm]	L+brake with opt. encoder G6.2x [mm]	L with opt. encoder G6.3x [mm]	L+brake with opt. encoder G6.3x [mm]
LSN-074-0115	101,5	148	99	In preparation	82	132
LSN-074-0205	119,5	166	117	In preparation	100	150
LSN-074-0350	155,5	202	153	In preparation	136	186
LSN-074-0480	191,5	238	189	In preparation	172	222

Table: Overview of motor lengths – for overview of encoder types see section 5.1



Technical data <sup>1)</sup>	Symbol	LSN-074-0115	LSN-074-0205	LSN-074-0350	LSN-074-0480
Rated speed	$n_n$	3000 rpm	3000 rpm	3000 rpm	3000 rpm
Rated frequency	$f_N$	250 Hz	250 Hz	250 Hz	250 Hz
DC link voltage (controller)	$U_{dc}$	320 V	320 V	320 V	320 V
Rated voltage	$U_n$	220 V	220 V	220 V	220 V
Rated torque	$M_n$	1.13 Nm	1.90 Nm	3.00 Nm	3.70 Nm
Rated current	$I_n$	2.30 A	3.10 A	4.30 A	4.50 A
Rated power	$P$	0.36 kW	0.60 kW	0.94 kW	1.16 kW
Stall torque	$M_0$	1.15 Nm	2.05 Nm	3.50 Nm	4.80 Nm
Stall current	$I_0$	2.00 A	2.80 A	4.20 A	4.80 A
Maximum permissible torque	$M_{max}$	3.50 Nm	6.20 Nm	10.50 Nm	14.40 Nm
Maximum permissible current	$I_{max}$	9.2 A	12.7 A	19.4 A	17.3 A
Maximum permissible speed	$n_{max}$	12000 rpm	12000 rpm	12000 rpm	12000 rpm
Voltage constant	$K_E$	34.5 V/1000 rpm	44.5 V/1000 rpm	50.0 V/1000 rpm	60.0 V/1000 rpm
Torque constant	$K_T$	0.57 Nm/A	0.74 Nm/A	0.83 Nm/	0.99 Nm/A
Winding resistance (2 phases)	$R_{2ph}$	8.40 $\Omega$	5.40 $\Omega$	2.80 $\Omega$	2.50 $\Omega$
Winding inductance (2 phases)	$L_{2ph}$	18.0 mH	13.3 mH	8.1 mH	7.5 mH
No load speed	$n_0$	6320 rpm	4920 rpm	4390 rpm	3660 rpm
Electrical time constant	$T_{el}$	2.1 ms	2.5 ms	2.9 ms	3.0 ms
Thermal time constant	$T_{th}$	21 min.	23 min.	27 min.	30 min.
Moment of inertia of the motor	$J$	0.000031 kgm <sup>2</sup>	0.000055 kgm <sup>2</sup>	0.000104 kgm <sup>2</sup>	0.000152 kgm <sup>2</sup>
Mass	$m$	1.50 kg	2.00 kg	2.90 kg	3.80 kg

Brake (optional)	
Rated voltage	$U_N$ 24 V $\pm$ 10 %
Rated current at 20 °C for venting	$I_N$ 0.50 A
Permissible maximum speed	$n_{max}$ 10000 rpm
Permissible friction energy	$W_R$ 0.58 x 10 <sup>6</sup> Ws
Mass moment of inertia	$J_B$ 0.000018 kgm <sup>2</sup>
Mass	$m$ 0.47 kg
Braking torque	$M_H$ 4.50 Nm

Additional technical data	
Protection	IP64, optionally IP65 or IP67
Electrical connections	Intercontec plug (x2)
Thermal motor protection	PTC, optionally thermoswitch 140° C, KTY or NTC
Nominal data	to EN 60034-1, $T_A = 40^\circ C$ , $T_{over} = 110 K$ , flange temperature $\leq 65^\circ C$
Servo amplifier	Stator windings for DC link voltage $U_{dc} = 320 V$ or 560 VDC, other voltages optional
Flange/shaft	to DIN 42955 N, optionally R

1) All values with a tolerance of  $\pm 10\%$ . Other windings/rated speeds possible. Subject to technical change without notice.

## 2.18.2 Characteristics

Explanations of characteristics:

The characteristic  $M_{\max}$  describes the maximum possible short-time torque at corresponding speed. It is important for dynamic processes.

The characteristic  $M_n$  indicates the thermally permissible rated torque.

The characteristics are limited by the respective maximum permissible speed  $n_{\max}$  (for  $n_{\max}$  refer to the "Technical data" table).

2

### LSN-074-0115-30-320

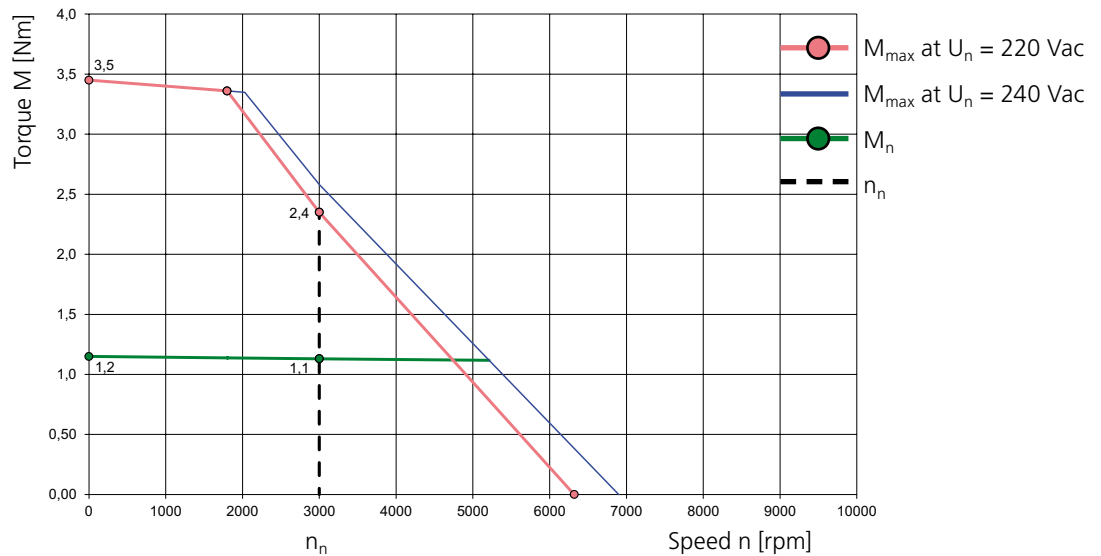

### LSN-074-0205-30-320

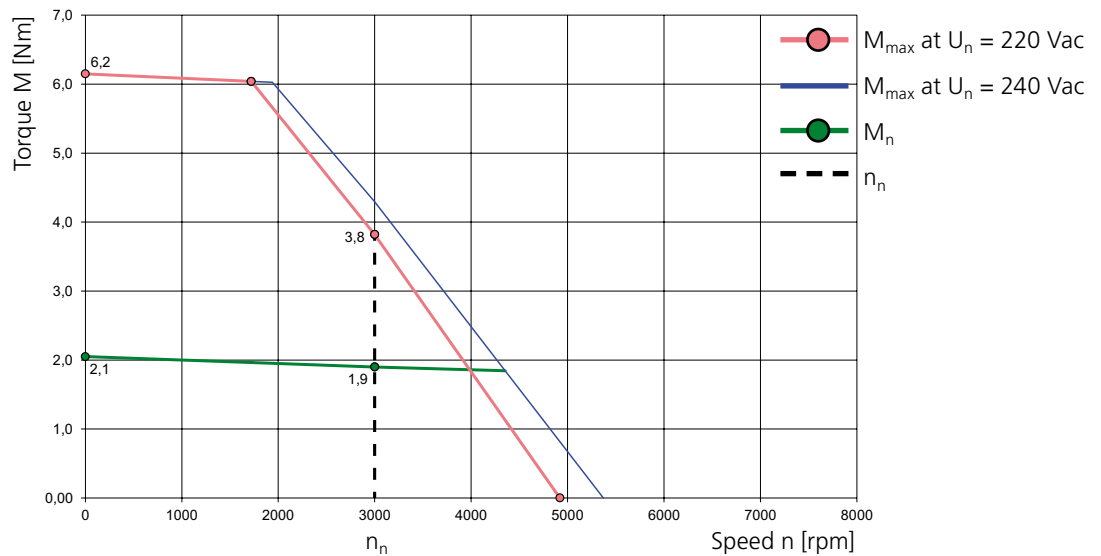

### LSN-074-0350-30-320

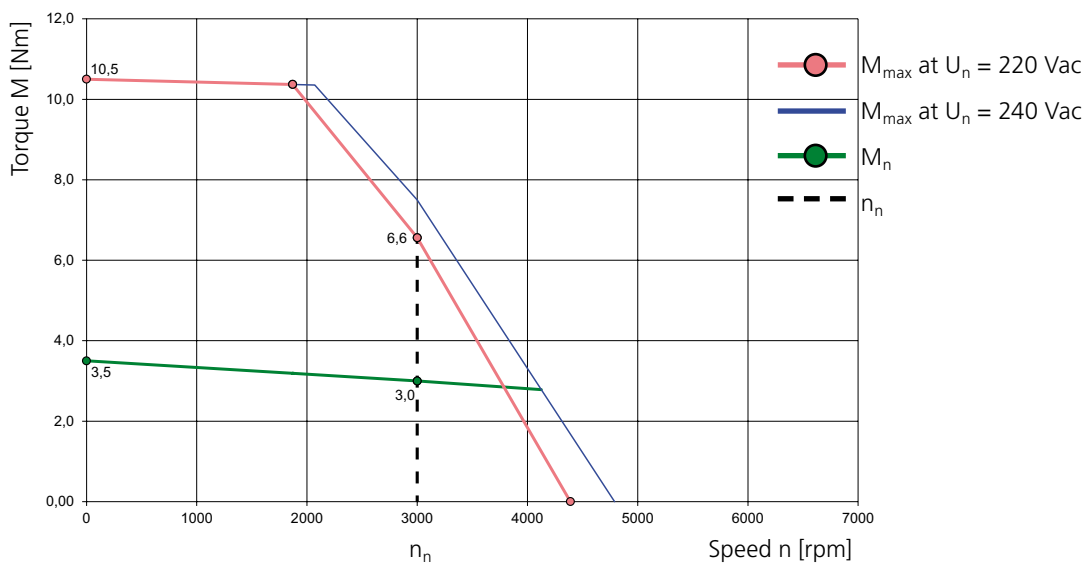

### LSN-074-0480-30-320

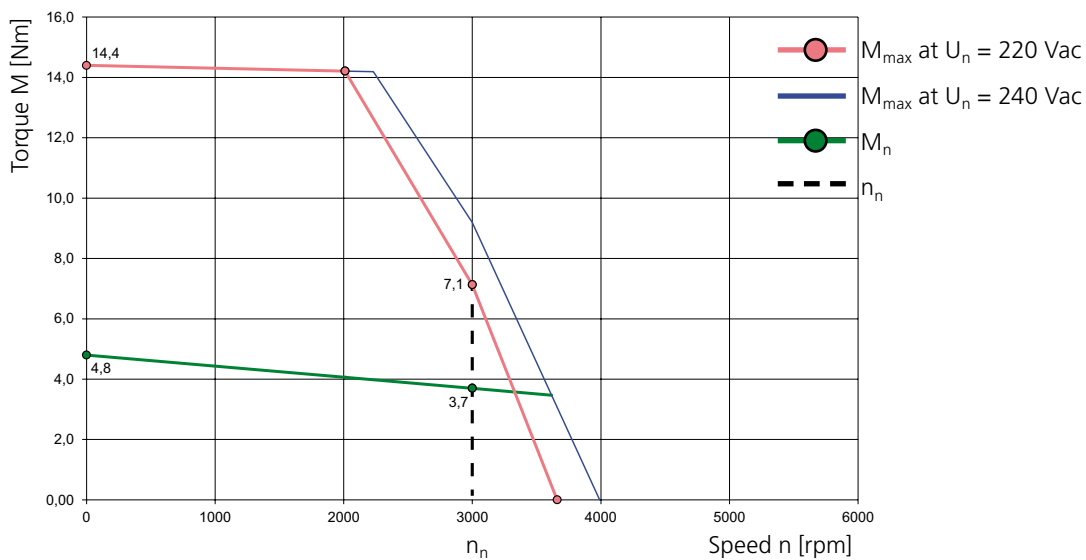

2.19 Motor type:  
LSN-074  
( $U_{dc} = 560 \text{ V}$ )



2

2.19.1 Dimensional sketch and technical data

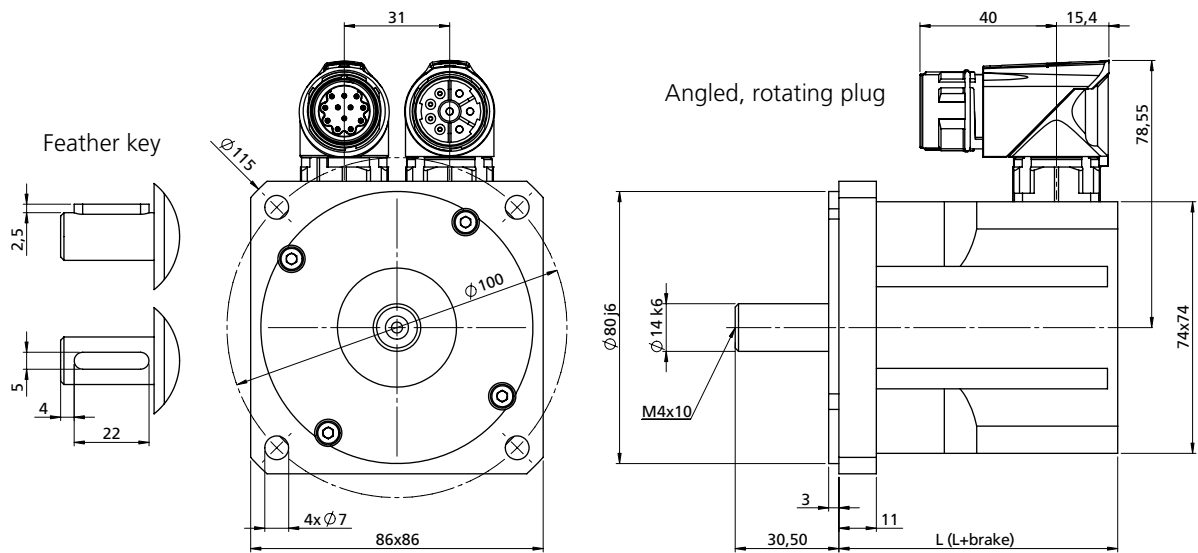

Motor type	L with resolver xR [mm]	L+brake with resolver xR [mm]	L with opt. encoder G12.xy [mm]	L+brake with opt. encoder G12.xy [mm]
LSN-074-0115	82	120	123	165.5
LSN-074-0205	100	138	141	183.5
LSN-074-0350	136	174	177	219.5
LSN-074-0480	172	210	213	In preparation

Motor type	L with opt. encoder G6.1x [mm]	L+brake with opt. encoder G6.1x [mm]	L with opt. encoder G6.2x [mm]	L+brake with opt. encoder G6.2x [mm]	L with opt. encoder G6.3x [mm]	L+brake with opt. encoder G6.3x [mm]
LSN-074-0115	101,5	148	99	In preparation	82	132
LSN-074-0205	119,5	166	117	In preparation	100	150
LSN-074-0350	155,5	202	153	In preparation	136	186
LSN-074-0480	191,5	238	189	In preparation	172	222

Table: Overview of motor lengths – for overview of encoder types see section 5.1

Technical data <sup>1)</sup>	Symbol	LSN-074-0115	LSN-074-0205	LSN-074-0350	LSN-074-0480
Rated speed	$n_n$	3000 rpm	3000 rpm	3000 rpm	3000 rpm
Rated frequency	$f_N$	250 Hz	250 Hz	250 Hz	250 Hz
DC link voltage (controller)	$U_{dc}$	560 V	560 V	560 V	560 V
Rated voltage	$U_n$	380 V	380 V	380 V	380 V
Rated torque	$M_n$	1.13 Nm	1.90 Nm	3.00 Nm	3.70 Nm
Rated current	$I_n$	1.30 A	1.70 A	2.40 A	2.60 A
Rated power	$P$	0.36 kW	0.60 kW	0.94 kW	1.16 kW
Stall torque	$M_0$	1.15 Nm	2.05 Nm	3.50 Nm	4.80 Nm
Stall current	$I_0$	1.10 A	1.60 A	2.40 A	2.80 A
Maximum permissible torque	$M_{max}$	3.50 Nm	6.20 Nm	10.50 Nm	14.40 Nm
Maximum permissible current	$I_{max}$	5.0 A	7.2 A	10.9 A	10.1 A
Maximum permissible speed	$n_{max}$	12000 rpm	12000 rpm	12000 rpm	12000 rpm
Voltage constant	$K_E$	63.0 V/1000 rpm	79.0 V/1000 rpm	89.0 V/1000 rpm	103.0 V/1000 rpm
Torque constant	$K_T$	1.04 Nm/A	1.31 Nm/A	1.47 Nm/	1.70 Nm/A
Winding resistance (2 phases)	$R_{2ph}$	27.80 $\Omega$	17.30 $\Omega$	8.90 $\Omega$	7.50 $\Omega$
Winding inductance (2 phases)	$L_{2ph}$	59.3 mH	42.4 mH	25.5 mH	22.7 mH
No load speed	$n_0$	5980 rpm	4790 rpm	4260 rpm	3680 rpm
Electrical time constant	$T_{el}$	2.1 ms	2.5 ms	2.9 ms	3.0 ms
Thermal time constant	$T_{th}$	21 min.	23 min.	27 min.	30 min.
Moment of inertia of the motor	$J$	0.000031 kgm <sup>2</sup>	0.000055 kgm <sup>2</sup>	0.000104 kgm <sup>2</sup>	0.000152 kgm <sup>2</sup>
Mass	$m$	1.50 kg	2.00 kg	2.90 kg	3.80 kg

#### Brake (optional)

Rated voltage	$U_N$	24 V $\pm$ 10 %
Rated current at 20 °C for venting	$I_N$	0.50 A
Permissible maximum speed	$n_{max}$	10000 rpm
Permissible friction energy	$W_R$	0.58 x 10 <sup>6</sup> Ws
Mass moment of inertia	$J_B$	0.000018 kgm <sup>2</sup>
Mass	$m$	0.47 kg
Braking torque	$M_H$	4.50 Nm

#### Additional technical data

Protection	IP64, optionally IP65 or IP67
Electrical connections	Intercontec plug (x2)
Thermal motor protection	PTC, optionally thermoswitch 140° C, KTY or NTC
Nominal data	to EN 60034-1, $T_A = 40^\circ \text{C}$ , $T_{over} = 110 \text{K}$ , flange temperature $\leq 65^\circ \text{C}$
Servo amplifier	Stator windings for DC link voltage $U_{dc} = 320 \text{V}$ or 560 VDC, other voltages optional
Flange/shaft	to DIN 42955 N, optionally R

<sup>1)</sup> All values with a tolerance of  $\pm 10\%$ . Other windings/rated speeds possible. Subject to technical change without notice.

## 2.19.2 Characteristics

Explanations of characteristics:

The characteristic  $M_{\max}$  describes the maximum possible short-time torque at corresponding speed. It is important for dynamic processes.

The characteristic  $M_n$  indicates the thermally permissible rated torque.

The characteristics are limited by the respective maximum permissible speed  $n_{\max}$  (for  $n_{\max}$  refer to the "Technical data" table).

2

### LSN-074-0115-30-560

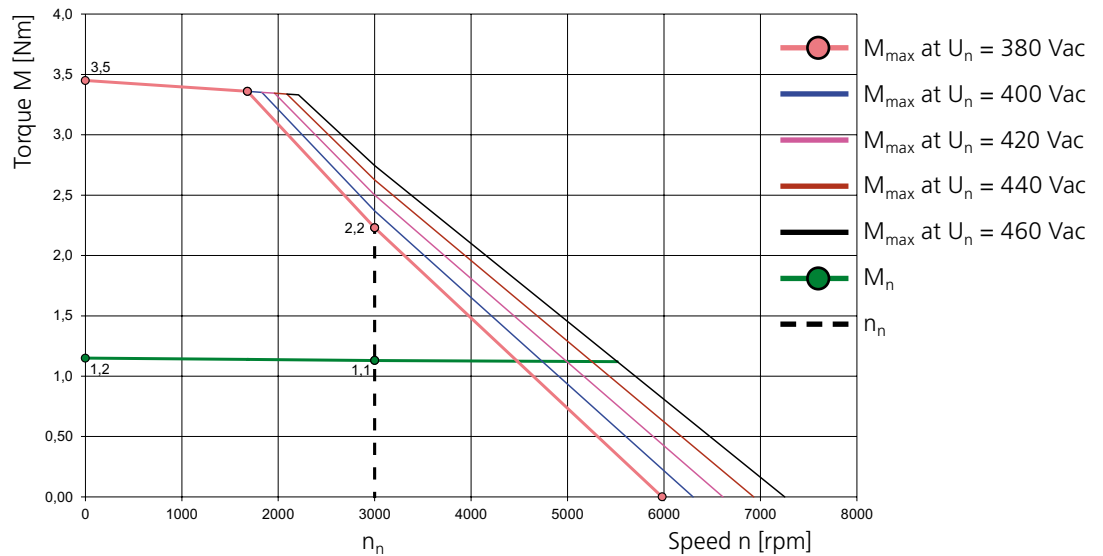

### LSN-074-0205-30-560

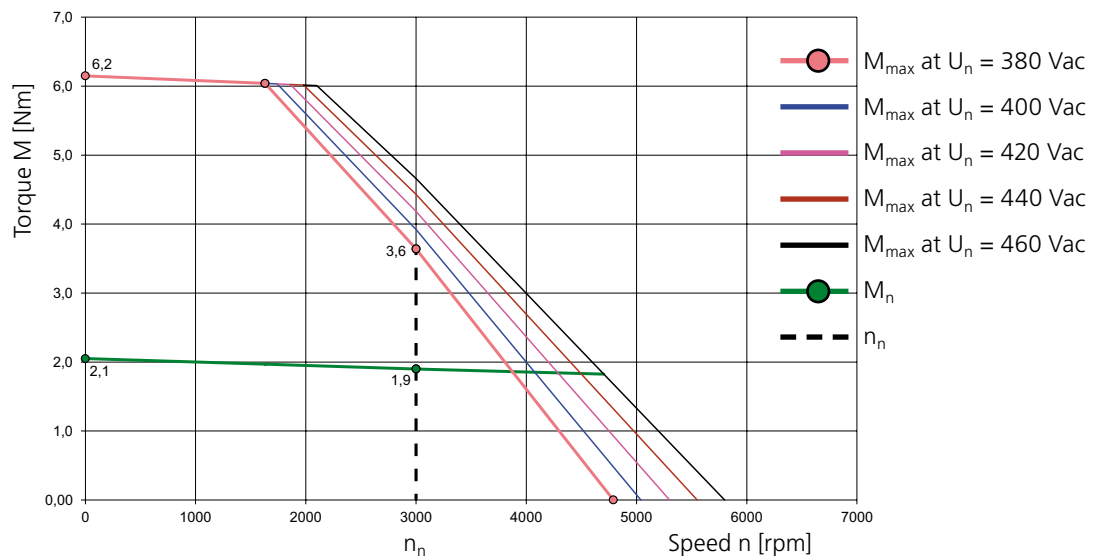

### LSN-074-0350-30-560

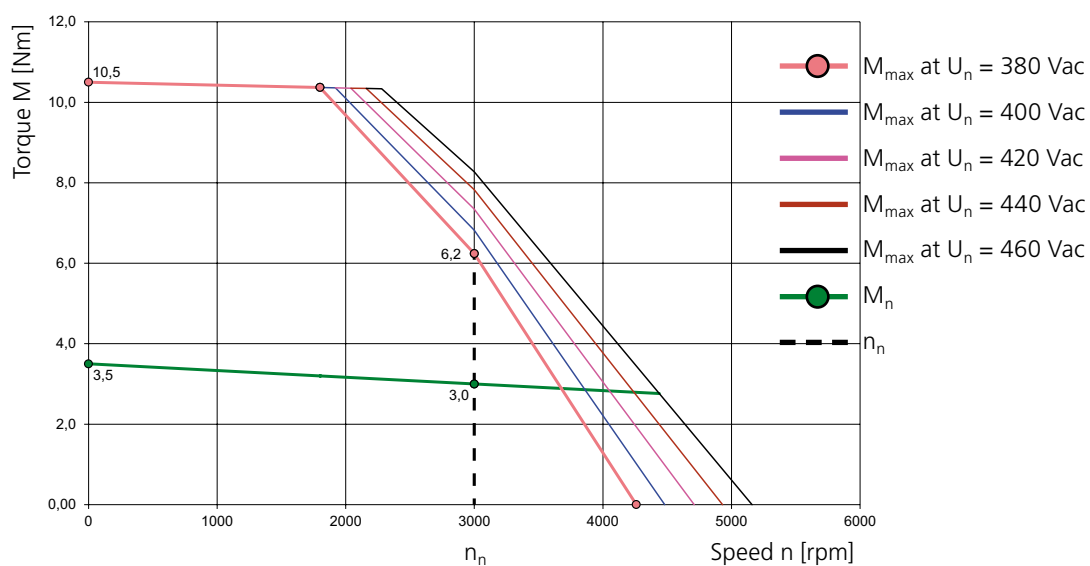

### LSN-074-0480-30-560

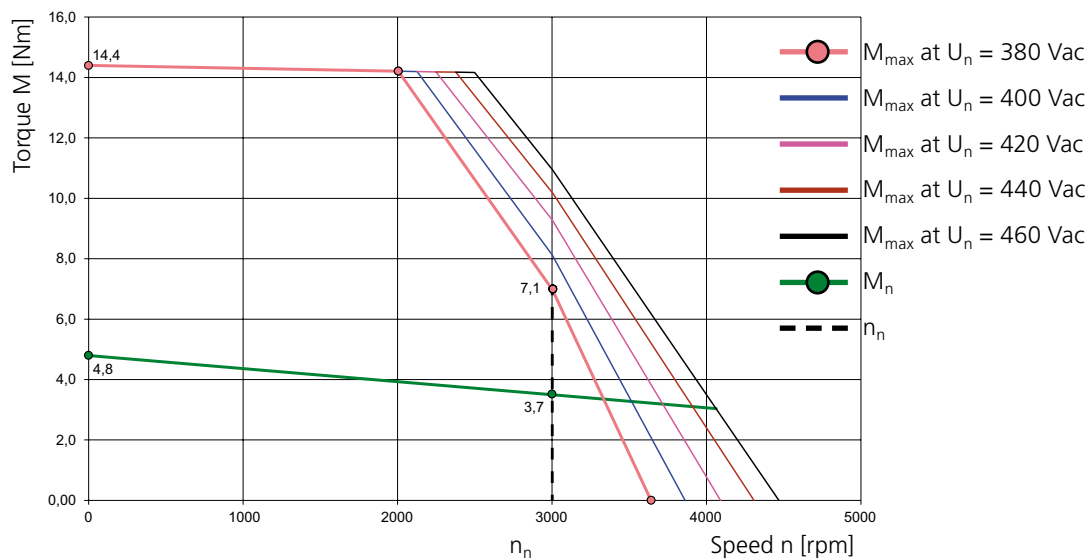

## 2.20 Motor type: LSN-097 ( $U_{dc} = 320\text{ V}$ )



2

### 2.20.1 Dimensional sketch and technical data

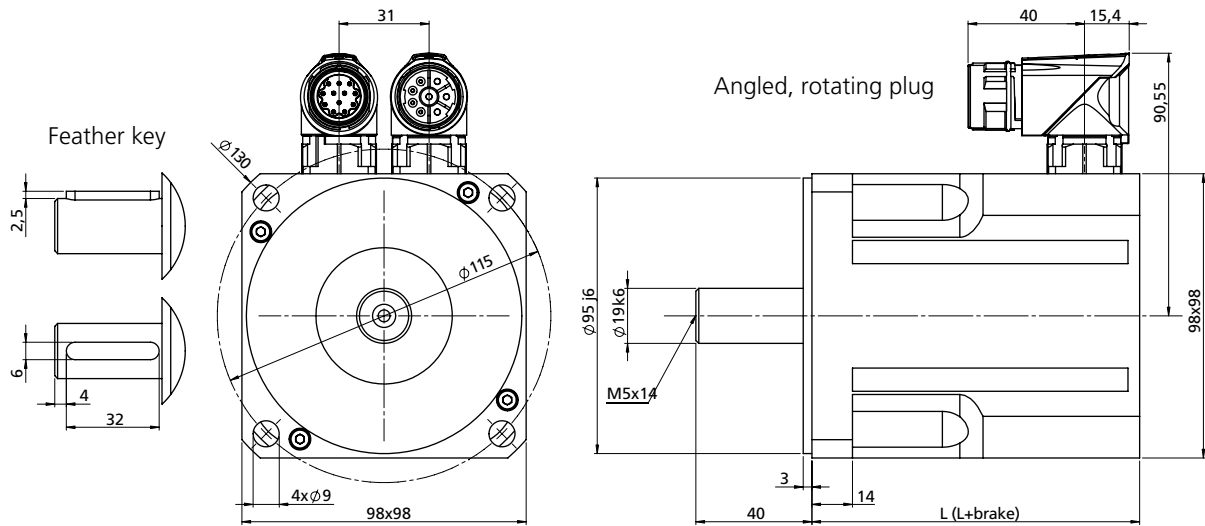

Motor type	L with resolver xR [mm]	L+brake with resolver xR [mm]	L with opt. encoder G12.xy [mm]	L+brake with opt. encoder G12.xy [mm]
LSN-097-0510	113	154	150	190.5
LSN-097-0750	143	184	180	220.5
LSN-097-0960	173	214	210	250.5
LSN-097-1130	203	244	240	280.5

Motor type	L with opt. encoder G6.1x [mm]	L+brake with opt. encoder G6.1x [mm]	L with opt. encoder G6.2x [mm]	L+brake with opt. encoder G6.2x [mm]	L with opt. encoder G6.3x [mm]	L+brake with opt. encoder G6.3x [mm]
LSN-097-0510	135	184	132	In preparation	113	158
LSN-097-0750	165	214	162	In preparation	143	188
LSN-097-0960	195	244	192	In preparation	173	218
LSN-097-1130	225	274	222	In preparation	203	248

Table: Overview of motor lengths – for overview of encoder types see section 5.1



Technical data <sup>1)</sup>	Symbol	LSN-097-0510	LSN-097-0750	LSN-097-0960	LSN-097-1130
Rated speed	$n_n$	3000 rpm	3000 rpm	3000 rpm	3000 rpm
Rated frequency	$f_N$	250 Hz	250 Hz	250 Hz	250 Hz
DC link voltage (controller)	$U_{dc}$	320 V	320 V	320 V	320 V
Rated voltage	$U_n$	220 V	220 V	220 V	220 V
Rated torque	$M_n$	4.20 Nm	6.10 Nm	7.70 Nm	8.80 Nm
Rated current	$I_n$	7.00 A	8.80 A	10.80 A	10.70 A
Rated power	$P$	1.32 kW	1.92 kW	2.42 kW	2.76 kW
Stall torque	$M_0$	5.10 Nm	7.50 Nm	9.60 Nm	11.30 Nm
Stall current	$I_0$	6.8 A	8.9 A	10.7 A	11.0 A
Maximum permissible torque	$M_{max}$	15.3 Nm	22.5 Nm	28.8 Nm	34.0 Nm
Maximum permissible current	$I_{max}$	31.0 A	40.7 A	49.2 A	41.0 A
Maximum permissible speed	$n_{max}$	9000 rpm	9000 rpm	9000 rpm	9000 rpm
Voltage constant	$K_E$	45.5 V/1000 rpm	51.0 V/1000 rpm	54.0 V/1000 rpm	62.0 V/1000 rpm
Torque constant	$K_T$	0.75 Nm/A	0.84 Nm/A	0.89 Nm/	1.03 Nm/A
Winding resistance (2 phases)	$R_{2ph}$	1.24 $\Omega$	0.79 $\Omega$	0.62 $\Omega$	0.61 $\Omega$
Winding inductance (2 phases)	$L_{2ph}$	6.8 mH	4.8 mH	3.6 mH	3.8 mH
No load speed	$n_0$	4800 rpm	4300 rpm	4060 rpm	3540 rpm
Electrical time constant	$T_{el}$	5.5 ms	6.1 ms	5.8 ms	6.2 ms
Thermal time constant	$T_{th}$	25 min.	30 min.	35 min.	40 min.
Moment of inertia of the motor	$J$	0.000204 kgm <sup>2</sup>	0.000326 kgm <sup>2</sup>	0.000449 kgm <sup>2</sup>	0.000570 kgm <sup>2</sup>
Mass	$m$	3.80 kg	5.10 kg	6.40 kg	7.70 kg

#### Brake (optional)

Rated voltage	$U_N$	24 V $\pm$ 10 %
Rated current at 20 °C for venting	$I_N$	0.75 A
Permissible maximum speed	$n_{max}$	10000 rpm
Permissible friction energy	$W_R$	0.89 x 10 <sup>6</sup> Ws
Mass moment of inertia	$J_B$	0.000054 kgm <sup>2</sup>
Mass	$m$	0.82 kg
Braking torque	$M_H$	9.00 Nm

#### Additional technical data

Protection	IP64, optionally IP65 or IP67
Electrical connections	Intercontec plug (x2)
Thermal motor protection	PTC, optionally thermoswitch 140° C, KTY or NTC
Nominal data	to EN 60034-1, $T_A = 40^\circ$ C, $T_{over} = 110$ K, flange temperature $\leq 65^\circ$ C
Servo amplifier	Stator windings for DC link voltage $U_{dc} = 320$ V or 560 VDC, other voltages optional
Flange/shaft	to DIN 42955 N, optionally R

<sup>1)</sup> All values with a tolerance of  $\pm 10\%$ . Other windings/rated speeds possible. Subject to technical change without notice.

## 2.2.0.2 Characteristics

Explanations of characteristics:

The characteristic  $M_{\max}$  describes the maximum possible short-time torque at corresponding speed. It is important for dynamic processes.

The characteristic  $M_n$  indicates the thermally permissible rated torque.

The characteristics are limited by the respective maximum permissible speed  $n_{\max}$  (for  $n_{\max}$  refer to the "Technical data" table).

2

### LSN-097-0510-30-320

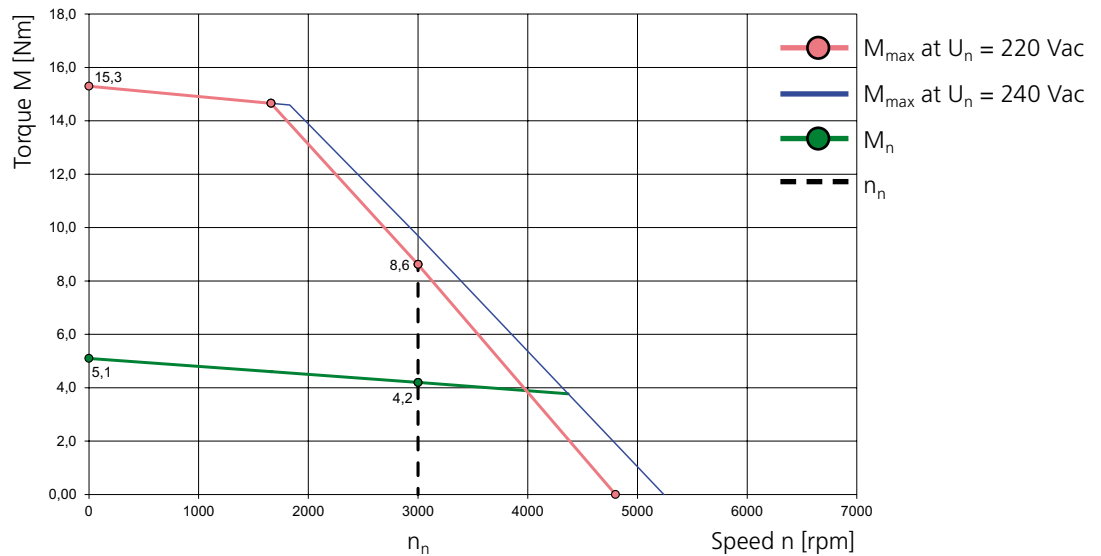

### LSN-097-0750-30-320

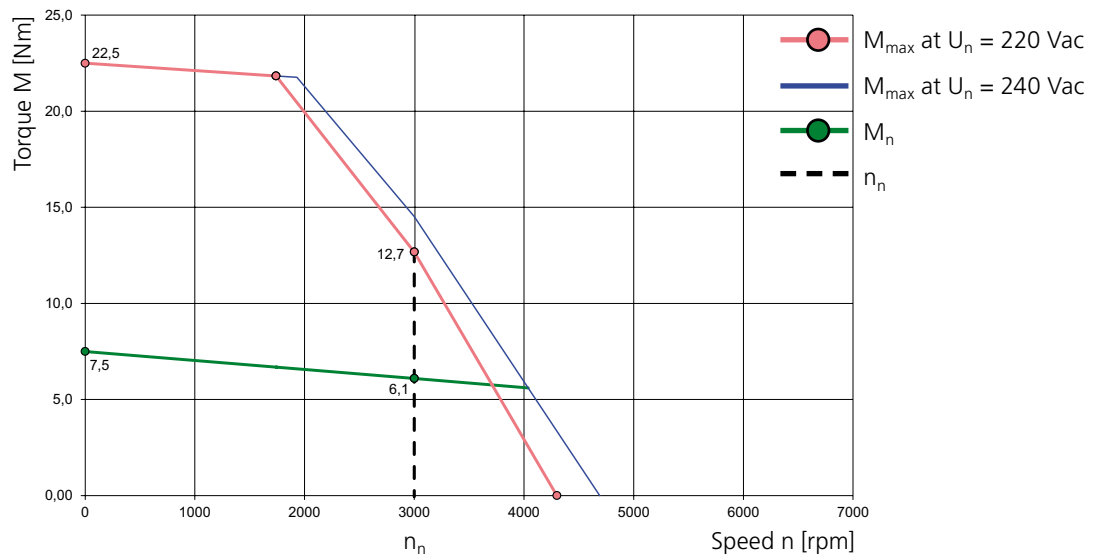

### LSN-097-0960-30-320

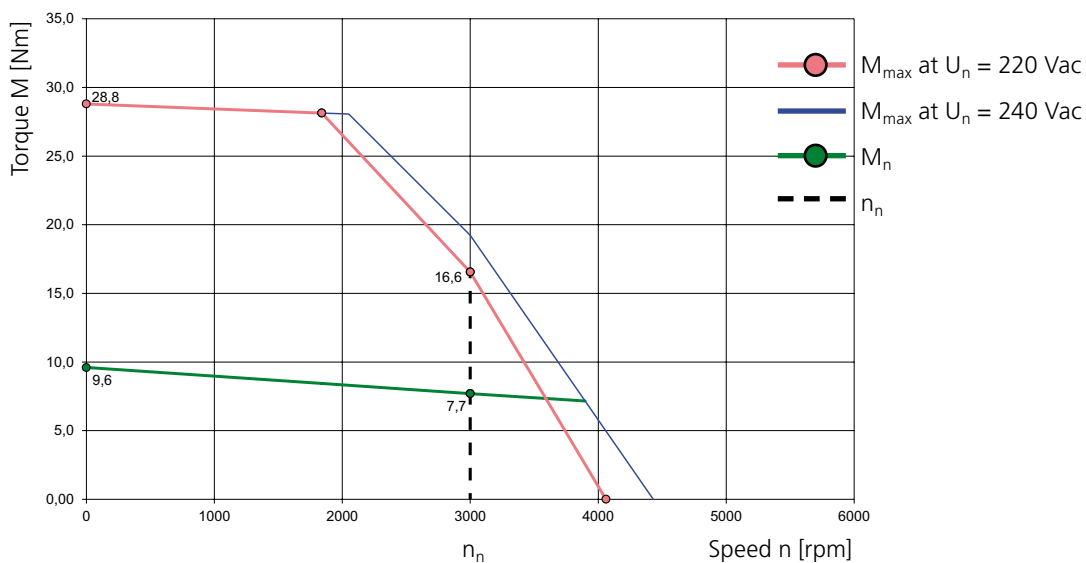

### LSN-097-1130-30-320

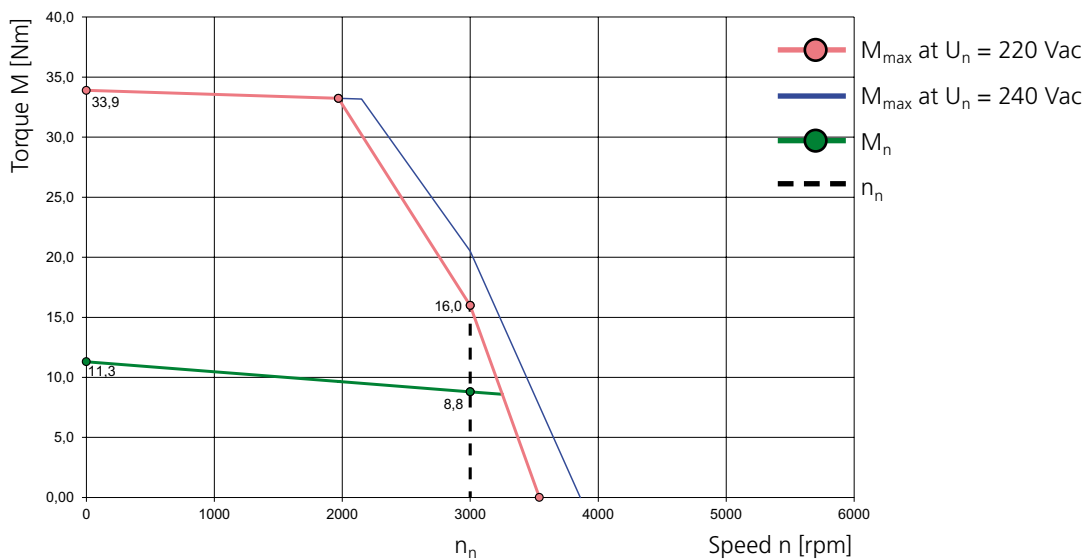

## 2.21 Motor type: LSN-097 ( $U_{dc} = 560\text{ V}$ )



### 2.21.1 Dimensional sketch and technical data

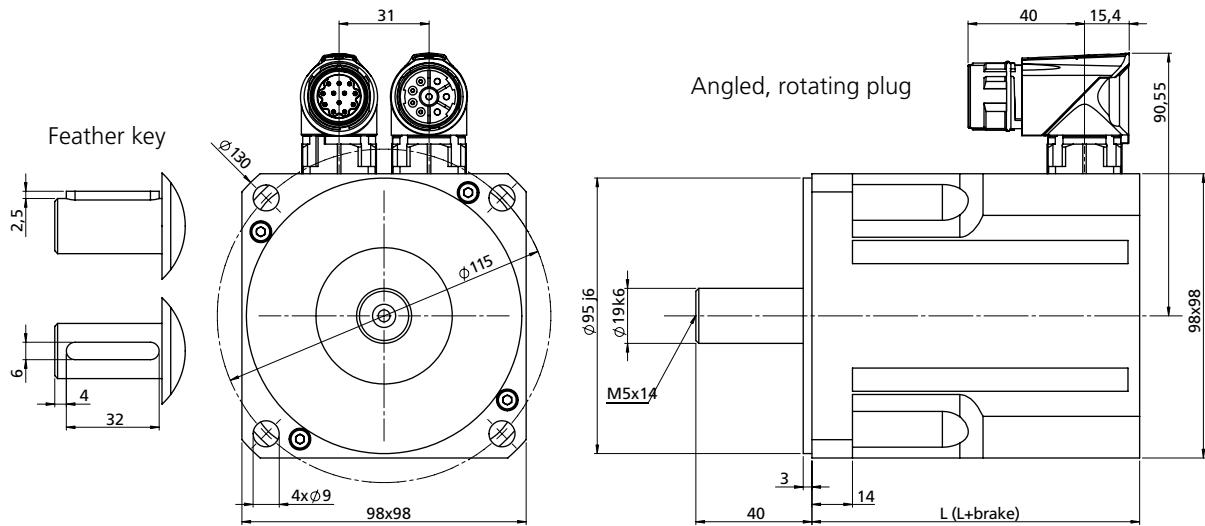

Motor type	L with resolver xR [mm]	L+brake with resolver xR [mm]	L with opt. encoder G12.xy [mm]	L+brake with opt. encoder G12.xy [mm]
LSN-097-0510	113	154	150	190.5
LSN-097-0750	143	184	180	220.5
LSN-097-0960	173	214	210	250.5
LSN-097-1130	203	244	240	280.5

Motor type	L with opt. encoder G6.1x [mm]	L+brake with opt. encoder G6.1x [mm]	L with opt. encoder G6.2x [mm]	L+brake with opt. encoder G6.2x [mm]	L with opt. encoder G6.3x [mm]	L+brake with opt. encoder G6.3x [mm]
LSN-097-0510	135	184	132	In preparation	113	158
LSN-097-0750	165	214	162	In preparation	143	188
LSN-097-0960	195	244	192	In preparation	173	218
LSN-097-1130	225	274	222	In preparation	203	248

Table: Overview of motor lengths – for overview of encoder types see section 5.1

Technical data <sup>1)</sup>	Symbol	LSN-097-0510	LSN-097-0750	LSN-097-0960	LSN-097-1130
Rated speed	$n_n$	3000 rpm	3000 rpm	3000 rpm	3000 rpm
Rated frequency	$f_N$	250 Hz	250 Hz	250 Hz	250 Hz
DC link voltage (controller)	$U_{dc}$	560 V	560 V	560 V	560 V
Rated voltage	$U_n$	380 V	380 V	380 V	380 V
Rated torque	$M_n$	4.20 Nm	6.10 Nm	7.70 Nm	8.80 Nm
Rated current	$I_n$	3.90 A	5.10 A	6.00 A	6.90 A
Rated power	$P$	1.32 kW	1.92 kW	2.42 kW	2.76 kW
Stall torque	$M_0$	5.10 Nm	7.50 Nm	9.60 Nm	11.30 Nm
Stall current	$I_0$	3.8 A	5.2 A	6.0 A	7.1 A
Maximum permissible torque	$M_{max}$	15.3 Nm	22.5 Nm	28.8 Nm	34.0 Nm
Maximum permissible current	$I_{max}$	17.4 A	23.8 A	27.4 A	27.0 A
Maximum permissible speed	$n_{max}$	9000 rpm	9000 rpm	9000 rpm	9000 rpm
Voltage constant	$K_E$	81.0 V/1000 rpm	87.0 V/1000 rpm	97.0 V/1000 rpm	96.0 V/1000 rpm
Torque constant	$K_T$	1.34 Nm/A	1.44 Nm/A	1.60 Nm/	1.59 Nm/A
Winding resistance (2 phases)	$R_{2ph}$	4.00 $\Omega$	2.29 $\Omega$	2.00 $\Omega$	1.49 $\Omega$
Winding inductance (2 phases)	$L_{2ph}$	21.7 mH	13.5 mH	11.9 mH	9.1 mH
No load speed	$n_0$	4650 rpm	4350 rpm	3910 rpm	3950 rpm
Electrical time constant	$T_{el}$	5.5 ms	5.9 ms	6.0 ms	6.1 ms
Thermal time constant	$T_{th}$	25 min.	30 min.	35 min.	40 min.
Moment of inertia of the motor	$J$	0.000204 kgm <sup>2</sup>	0.000326 kgm <sup>2</sup>	0.000449 kgm <sup>2</sup>	0.000570 kgm <sup>2</sup>
Mass	$m$	3.80 kg	5.10 kg	6.40 kg	7.70 kg

#### Brake (optional)

Rated voltage	$U_N$	24 V $\pm$ 10 %
Rated current at 20 °C for venting	$I_N$	0.75 A
Permissible maximum speed	$n_{max}$	10000 rpm
Permissible friction energy	$W_R$	0.89 x 10 <sup>6</sup> Ws
Mass moment of inertia	$J_B$	0.000054 kgm <sup>2</sup>
Mass	$m$	0.82 kg
Braking torque	$M_H$	9.00 Nm

#### Additional technical data

Protection	IP64, optionally IP65 or IP67
Electrical connections	Intercontec plug (x2)
Thermal motor protection	PTC, optionally thermoswitch 140° C, KTY or NTC
Nominal data	to EN 60034-1, $T_A = 40^\circ \text{C}$ , $T_{over} = 110 \text{K}$ , flange temperature $\leq 65^\circ \text{C}$
Servo amplifier	Stator windings for DC link voltage $U_{dc} = 320 \text{V}$ or 560 VDC, other voltages optional
Flange/shaft	to DIN 42955 N, optionally R

<sup>1)</sup> All values with a tolerance of  $\pm 10\%$ . Other windings/rated speeds possible. Subject to technical change without notice.

## 2.21.2 Characteristics

Explanations of characteristics:

The characteristic  $M_{\max}$  describes the maximum possible short-time torque at corresponding speed. It is important for dynamic processes.

The characteristic  $M_n$  indicates the thermally permissible rated torque.

The characteristics are limited by the respective maximum permissible speed  $n_{\max}$  (for  $n_{\max}$  refer to the "Technical data" table).

2

### LSN-097-0510-30-560

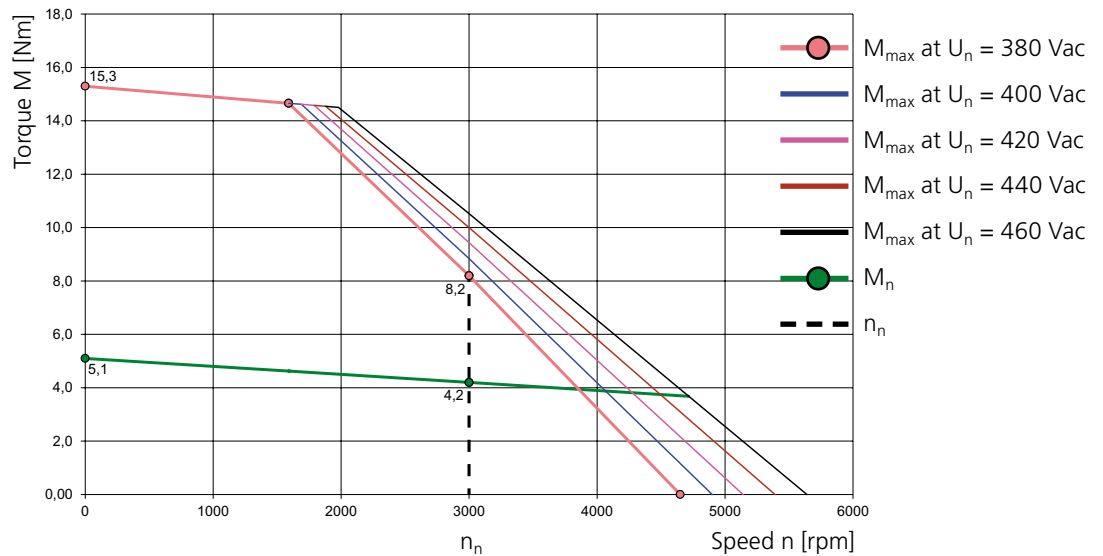

### LSN-097-0750-30-560

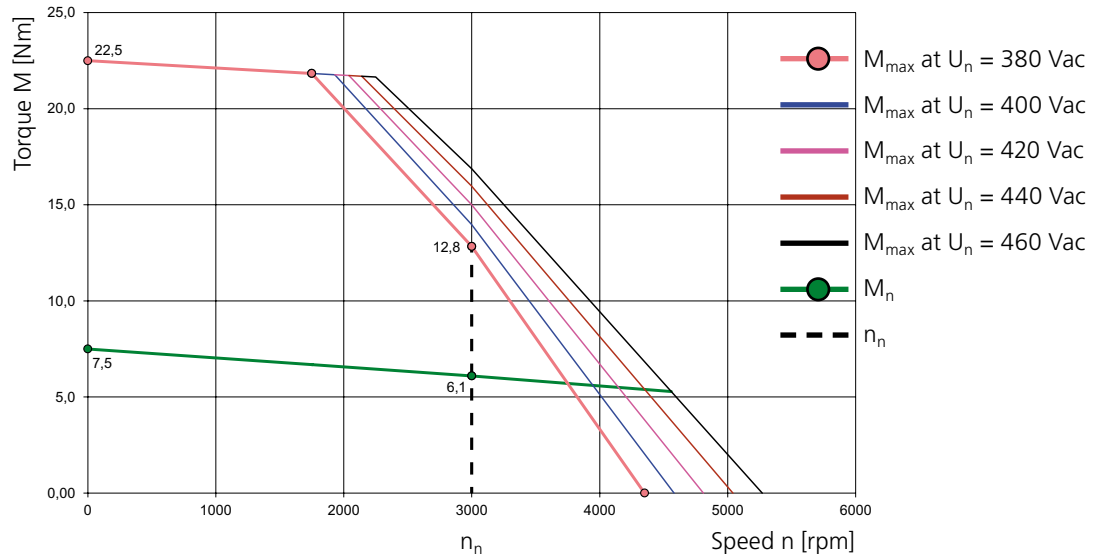

### LSN-097-0960-30-560

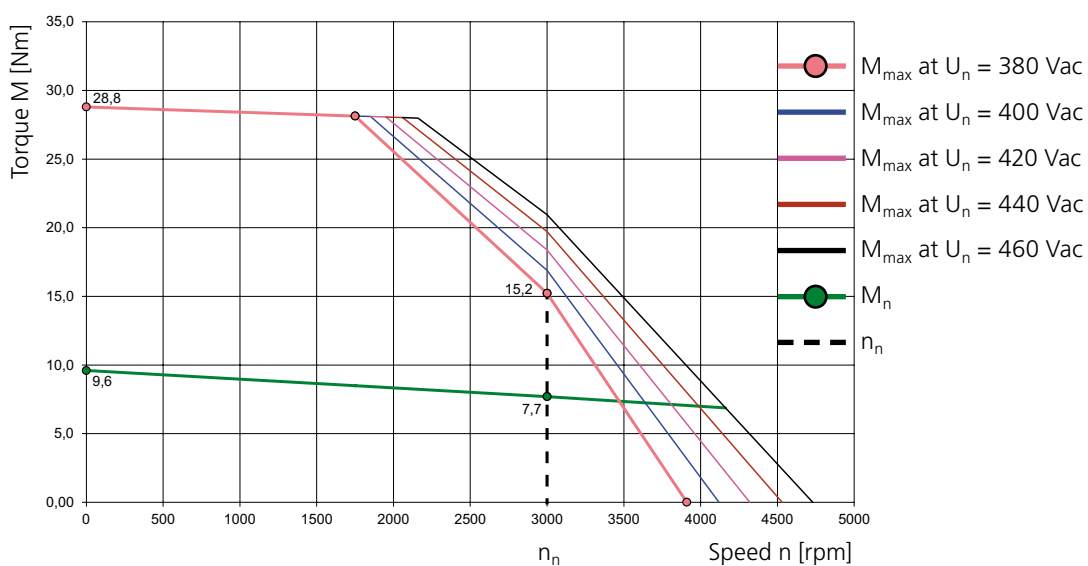

### LSN-097-1130-30-560

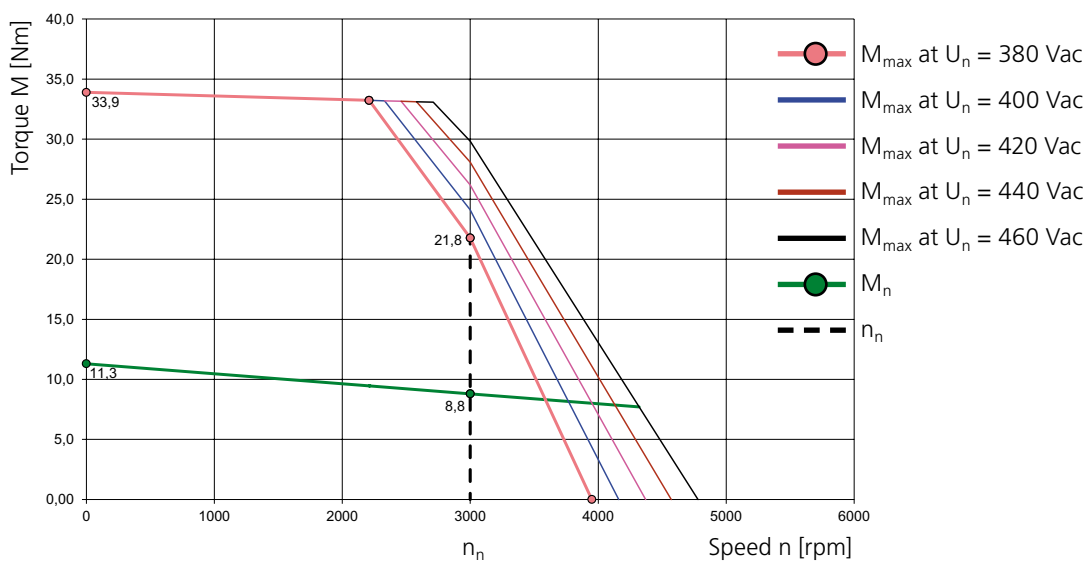

## 2.22 Motor type: LSN-127 ( $U_{dc} = 560 \text{ V}$ )



### 2.22.1 Dimensional sketch and technical data

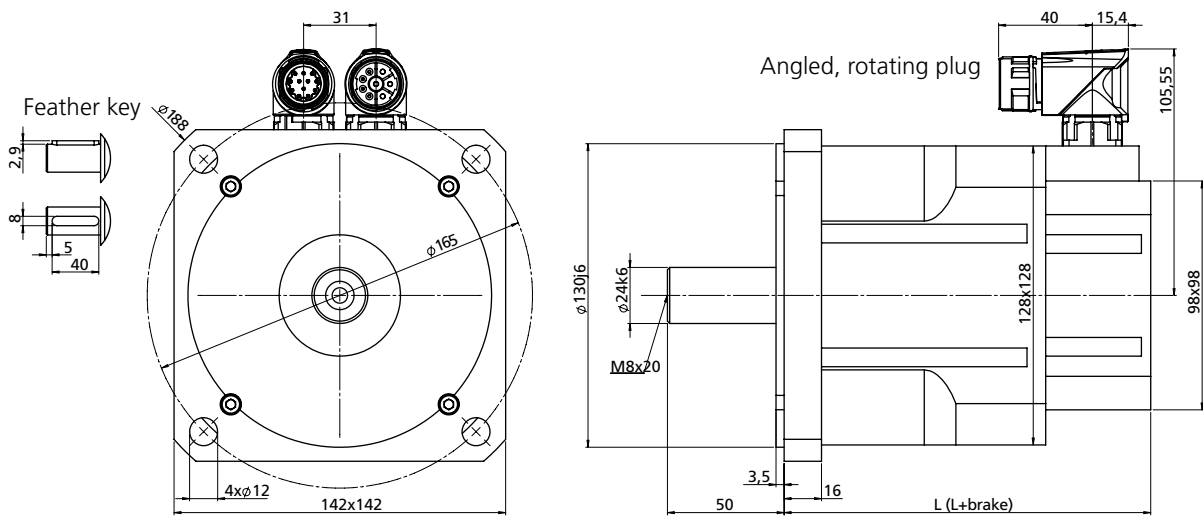

Motor type	L with resolver xR [mm]	L+brake with resolver xR [mm]	L with opt. encoder G12.xy [mm]	L+brake with opt. encoder G12.xy [mm]
LSN-127-1200	145	181	177	224
LSN-127-1600	175	211	207	254
LSN-127-2000	205	241	237	284
LSN-127-2400	235	271	267	314

Motor type	L with opt. encoder G6.1x [mm]	L+brake with opt. encoder G6.1x [mm]	L with opt. encoder G6.2x [mm]	L+brake with opt. encoder G6.2x [mm]	L with opt. encoder G6.3x [mm]	L+brake with opt. encoder G6.3x [mm]
LSN-127-1200	173	209	157	206	166	179,5*
LSN-127-1600	203	239	187	236	196	209,5*
LSN-127-2000	233	269	217	266	226	239,5*
LSN-127-2400	263	299	247	296	256	269,5*

Table: Overview of motor lengths – for overview of encoder types see section 5.1



Technical data <sup>1)</sup>	Symbol	LSN-127-1200	LSN-127-1600	LSN-127-2000	LSN-127-2400
Rated speed	$n_n$	3000 rpm	3000 rpm	3000 rpm	3000 rpm
Rated frequency	$f_N$	250 Hz	250 Hz	166.67 Hz	166.67 Hz
DC link voltage (controller)	$U_{dc}$	560 V	560 V	560 V	560 V
Rated voltage	$U_n$	380 V	380 V	380 V	380 V
Rated torque	$M_n$	10.50 Nm	13.80 Nm	16.00 Nm	20.00 Nm
Rated current	$I_n$	8.30 A	9.90 A	11.50 A	14.10 A
Rated power	$P$	3.30 kW	4.33 kW	5.03 kW	6.28 kW
Stall torque	$M_0$	12.0 Nm	16.0 Nm	20.0 Nm	24.0 Nm
Stall current	$I_0$	8,0 A	10.1 A	11.6 A	13.8 A
Maximum permissible torque	$M_{max}$	36.0 Nm	48.0 Nm	60.0 Nm	72.0 Nm
Maximum permissible current	$I_{max}$	29.0 A	36.0 A	40.0 A	47.0 A
Maximum permissible speed	$n_{max}$	9000 rpm	9000 rpm	9000 rpm	9000 rpm
Voltage constant	$K_E$	91.0 V/1000 rpm	96.0 V/1000 rpm	104.0 V/1000 rpm	105.0 V/1000 rpm
Torque constant	$K_T$	1.51 Nm/A	1.59 Nm/A	1.72 Nm/	1.74 Nm/A
Winding resistance (2 phases)	$R_{2ph}$	1.33 $\Omega$	0.88 $\Omega$	0.72 $\Omega$	0.56 $\Omega$
Winding inductance (2 phases)	$L_{2ph}$	10.9 mH	7.5 mH	6.3 mH	4.9 mH
No load speed	$n_0$	4170 rpm	3950 rpm	3650 rpm	3650 rpm
Electrical time constant	$T_{el}$	8.2 ms	8.5 ms	8.8 ms	8.8 ms
Thermal time constant	$T_{th}$	45 min.	55 min.	65 min.	75 min.
Moment of inertia of the motor	$J$	0.00096 kgm <sup>2</sup>	0.00133 kgm <sup>2</sup>	0.00171 kgm <sup>2</sup>	0.00208 kgm <sup>2</sup>
Mass	$m$	7.50 kg	9.50 kg	11.5 kg	13.5 kg

#### Brake (optional)

Rated voltage	$U_N$	24 V $\pm$ 10 %
Rated current at 20 °C for venting	$I_N$	1.00 A
Permissible maximum speed	$n_{max}$	10000 rpm
Permissible friction energy	$W_R$	1.29 x 10 <sup>6</sup> Ws
Mass moment of inertia	$J_B$	0.000166 kgm <sup>2</sup>
Mass	$m$	1.80 kg
Braking torque	$M_H$	18.00 Nm

#### Additional technical data

Protection	IP64, optionally IP65 or IP67
Electrical connections	Intercontec plug (x2)
Thermal motor protection	PTC, optionally thermoswitch 140° C, KTY or NTC
Nominal data	to EN 60034-1, $T_A = 40^\circ \text{C}$ , $T_{over} = 110 \text{K}$ , flange temperature $\leq 65^\circ \text{C}$
Servo amplifier	Stator windings for DC link voltage $U_{dc} = 320 \text{V}$ or 560 VDC, other voltages optional
Flange/shaft	to DIN 42955 N, optionally R

<sup>1)</sup> All values with a tolerance of  $\pm 10\%$ . Other windings/rated speeds possible. Subject to technical change without notice.

## 2.22.2 Characteristics

Explanations of characteristics:

The characteristic  $M_{\max}$  describes the maximum possible short-time torque at corresponding speed. It is important for dynamic processes.

The characteristic  $M_n$  indicates the thermally permissible rated torque.

The characteristics are limited by the respective maximum permissible speed  $n_{\max}$  (for  $n_{\max}$  refer to the "Technical data" table).

2

### LSN-127-1200-30-560

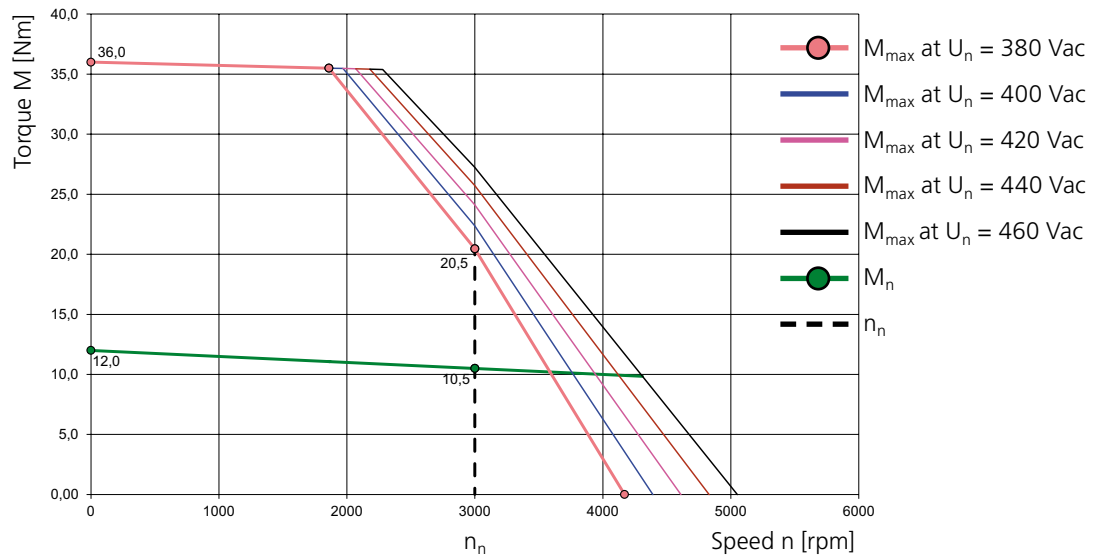

### LSN-127-1600-30-560

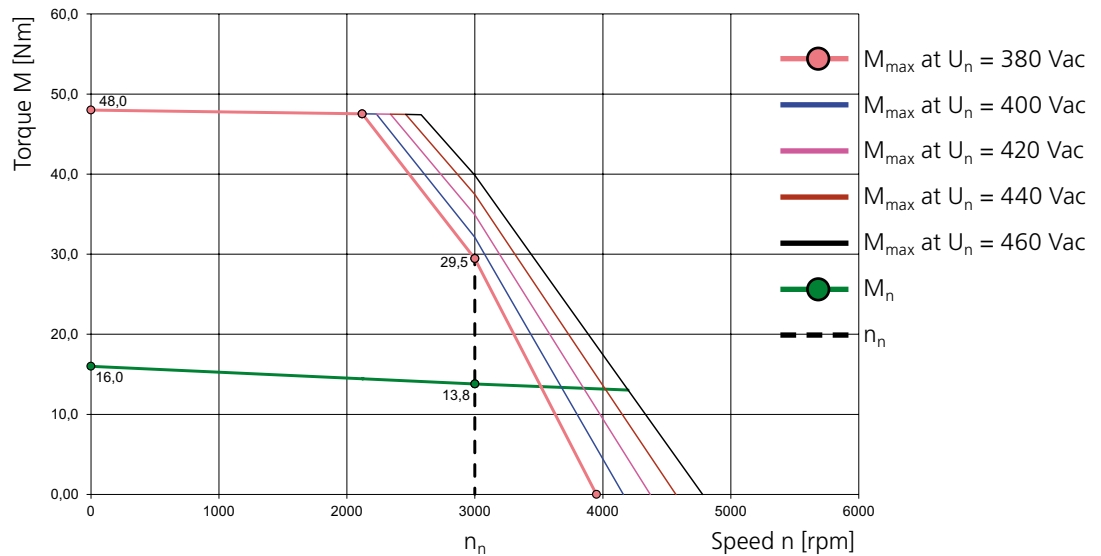

### LSN-127-2000-30-560

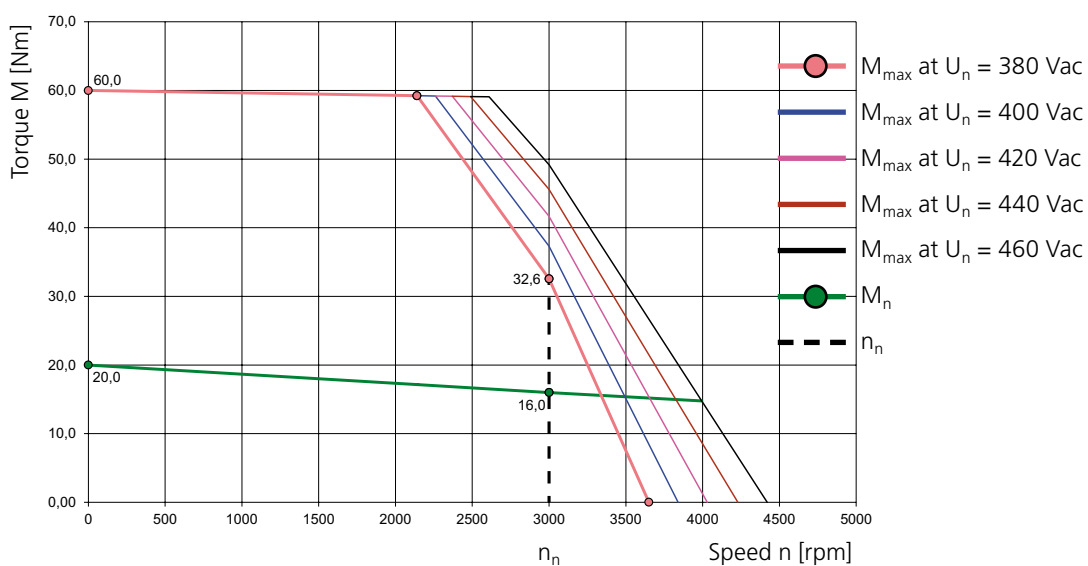

### LSN-127-2400-30-560

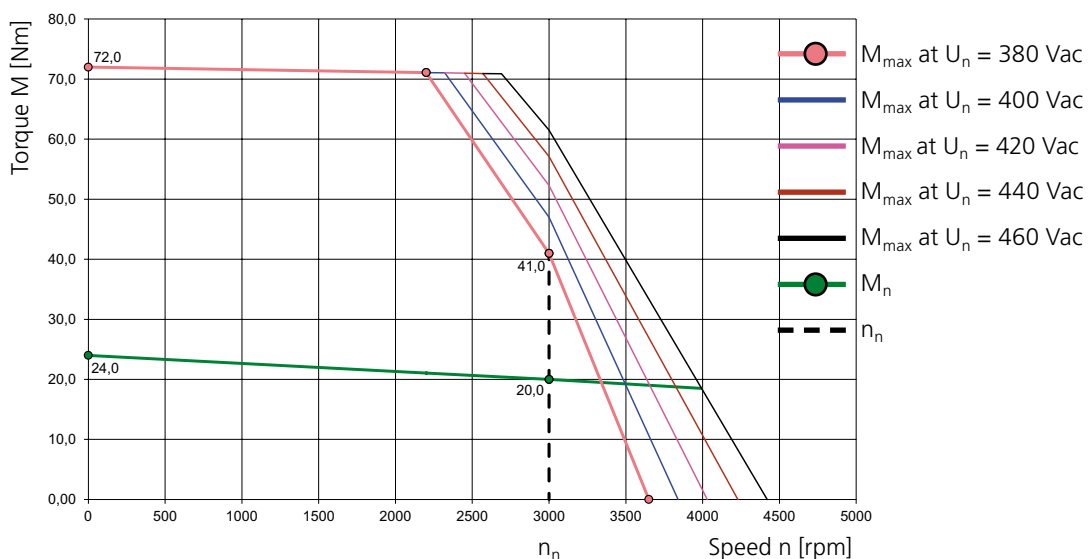



## 2.23 Motor type: LSN-158 ( $U_{dc} = 560 \text{ V}$ , $n_n = 2000 \text{ rpm}$ )

### 2.23.1 Dimensional sketch and technical data

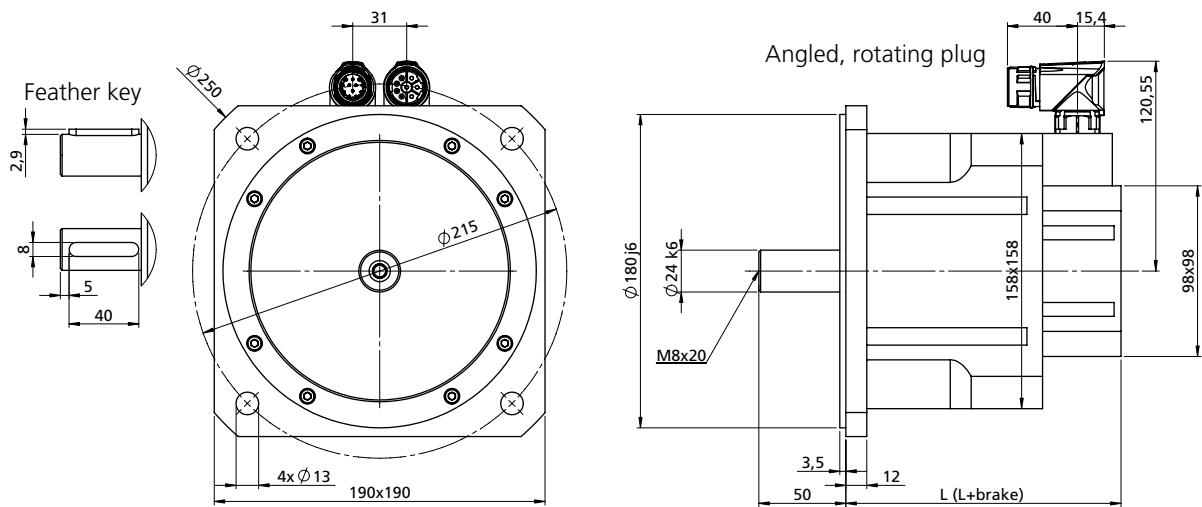

Motor type	L with resolver xR [mm]	L+brake with resolver xR [mm]	L with opt. encoder G12.xy [mm]	L+brake with opt. encoder G12.xy [mm]
LSN-158-1800	158	222	In preparation	In preparation
LSN-158-2400	183	247	In preparation	In preparation
LSN-158-3000	208	272	In preparation	In preparation
LSN-158-3800	233	297	In preparation	In preparation
LSN-158-4400	258	322	In preparation	In preparation

Motor type	L with opt. encoder G6.1x [mm]	L+brake with opt. encoder G6.1x [mm]	L with opt. encoder G6.2x [mm]	L+brake with opt. encoder G6.2x [mm]	L with opt. encoder G6.3x [mm]	L+brake with opt. encoder G6.3x [mm]
LSN-158-1800	161	In preparation	158	In preparation	In preparation	158
LSN-158-2400	186	In preparation	183	In preparation	In preparation	183
LSN-158-3000	211	In preparation	208	In preparation	In preparation	208
LSN-158-3800	236	In preparation	233	In preparation	In preparation	233
LSN-158-4400	261	In preparation	258	In preparation	In preparation	258

Table: Overview of motor lengths – for overview of encoder types see section 5.1

Technical data <sup>1)</sup>	Sym- bol	LSN-158- 1800-20	LSN-158- 2400-20	LSN-158- 3000-20	LSN-158- 3800-20	LSN-158- 4400-20
Rated speed	$n_n$	2000 rpm	2000 rpm	2000 rpm	2000 rpm	2000 rpm
Rated frequency	$f_N$	166.67 Hz	166.67 Hz	166.67 Hz	166.67 Hz	166.67 Hz
DC link voltage (controller)	$U_{dc}$	560 V	560 V	560 V	560 V	560 V
Rated voltage	$U_n$	380 V	380 V	380 V	380 V	380 V
Rated torque	$M_n$	14.80 Nm	20.00 Nm	25.30 Nm	29.00 Nm	36.50 Nm
Rated current	$I_n$	8.60 A	10.70 A	12.90 A	15.00 A	17.30 A
Rated power	$P$	3.01 kW	4.19 kW	5.30 kW	6.07 kW	7.64 kW
Stall torque	$M_0$	18.0 Nm	24.0 Nm	30.0 Nm	38.0 Nm	44.0 Nm
Stall current	$I_0$	8.9 A	10.8 A	12.8 A	16.7 A	17.7 A
Maximum permissible torque	$M_{max}$	51.0 Nm	72.0 Nm	90.0 Nm	114.0 Nm	132.0 Nm
Maximum permissible current	$I_{max}$	33.0 A	42.0 A	46.0 A	64.0 A	64.0 A
Maximum permissible speed	$n_{max}$	6000 rpm	6000 rpm	6000 rpm	6000 rpm	6000 rpm
Voltage constant	$K_E$	123.0 V/ 1000 rpm	134.0 V/ 1000 rpm	142.0 V/ 1000 rpm	138.0 V/ 1000 rpm	150.0 V/ 1000 rpm
Torque constant	$K_T$	2.00 Nm/A	2.20 Nm/A	2.40 Nm/A	2.30 Nm/A	2.50 Nm/A
Winding resistance (2 phases)	$R_{2ph}$	1.19 $\Omega$	0.81 $\Omega$	0.63 $\Omega$	0.52 $\Omega$	0.49 $\Omega$
Winding inductance (2 phases)	$L_{2ph}$	13.7 mH	10.8 mH	9.2 mH	7.2 mH	7.0 mH
No load speed	$n_0$	3090 rpm	2830 rpm	5130 rpm	2750 rpm	2750 rpm
Electrical time constant	$T_{el}$	11.5 ms	13.3 ms	14.5 ms	13.8 ms	14.4 ms
Thermal time constant	$T_{th}$	42 min.	47 min.	52 min.	57 min.	62 min.
Moment of inertia of the motor	$J$	0.00185 kgm <sup>2</sup>	0.00256 kgm <sup>2</sup>	0.00327 kgm <sup>2</sup>	0.00399 kgm <sup>2</sup>	0.00470 kgm <sup>2</sup>
Mass	$m$	10.1 kg	12.8 kg	15.5 kg	18.3 kg	21.0 kg

#### Brake (optional)

Rated voltage	$U_N$	24 V $\pm$ 10 %
Rated current at 20 °C for venting	$I_N$	1.10 A
Permissible maximum speed	$n_{max}$	10000 rpm
Permissible friction energy	$W_R$	2.90 x 10 <sup>6</sup> Ws
Mass moment of inertia	$J_B$	0.000556 kgm <sup>2</sup>
Mass	$m$	2.85 kg
Braking torque	$M_H$	36.00 Nm

#### Additional technical data

Protection	IP64, optionally IP65 or IP67
Electrical connections	Intercontec plug (x2)
Thermal motor protection	PTC, optionally thermoswitch 140° C, KTY or NTC
Nominal data	to EN 60034 <sup>-1</sup> , $T_A = 40^\circ \text{C}$ , $T_{over} = 110 \text{K}$ , flange temperature $\leq 65^\circ \text{C}$
Servo amplifier	Stator windings for DC link voltage $U_{dc} = 320 \text{V}$ or 560 VDC, other voltages optional
Flange/shaft	to DIN 42955 N, optionally R

1) All values with a tolerance of  $\pm 10\%$ . Other windings/rated speeds possible. Subject to technical change without notice.

## 2.23.2 Characteristics

Explanations of characteristics:

The characteristic  $M_{\max}$  describes the maximum possible short-time torque at corresponding speed. It is important for dynamic processes.

The characteristic  $M_n$  indicates the thermally permissible rated torque.

The characteristics are limited by the respective maximum permissible speed  $n_{\max}$  (for  $n_{\max}$  refer to the "Technical data" table).

2

### LSN-158-1800-20-560

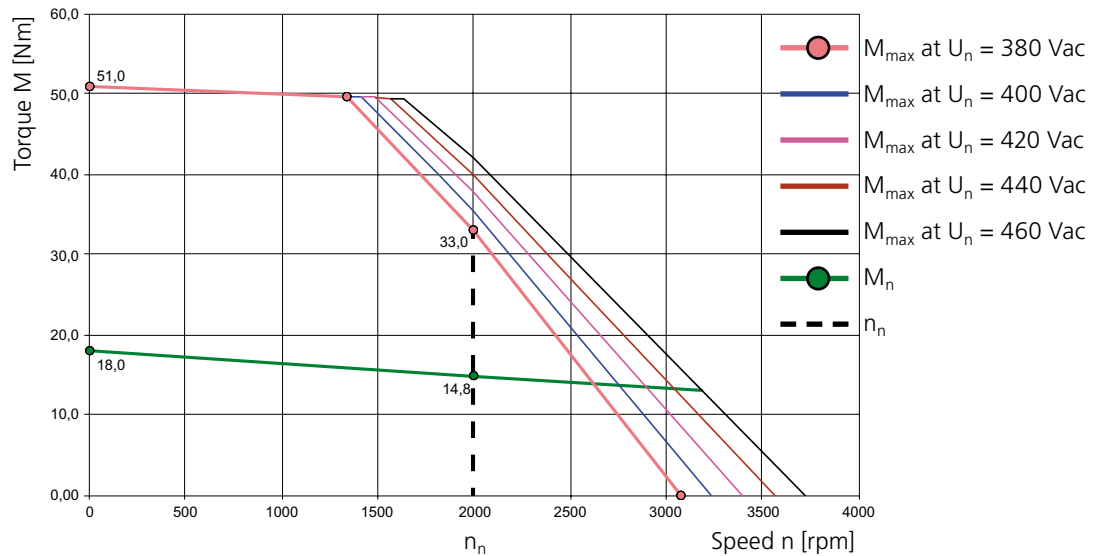

### LSN-158-2400-20-560

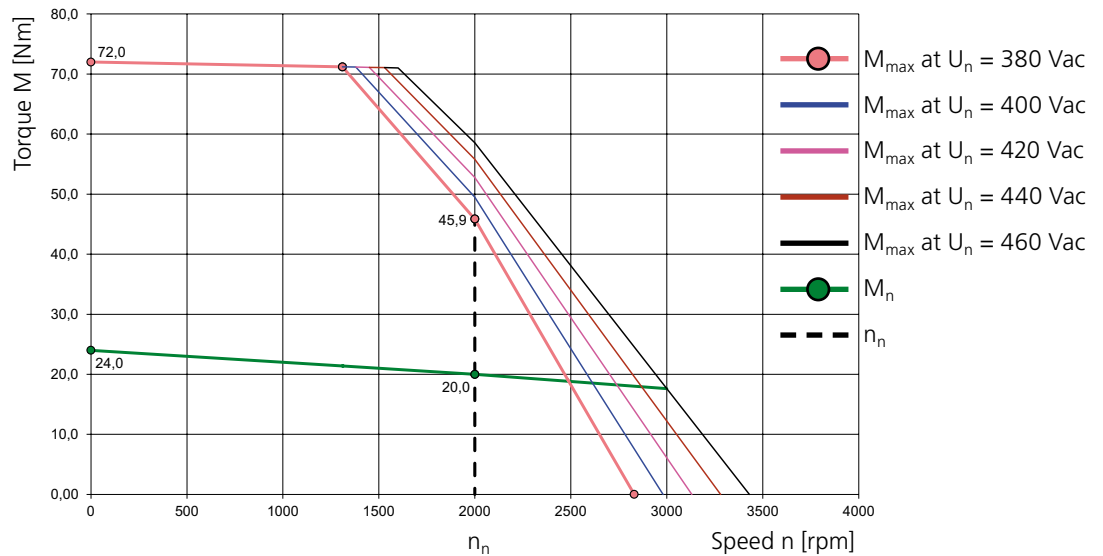

### LSN-158-3000-20-560

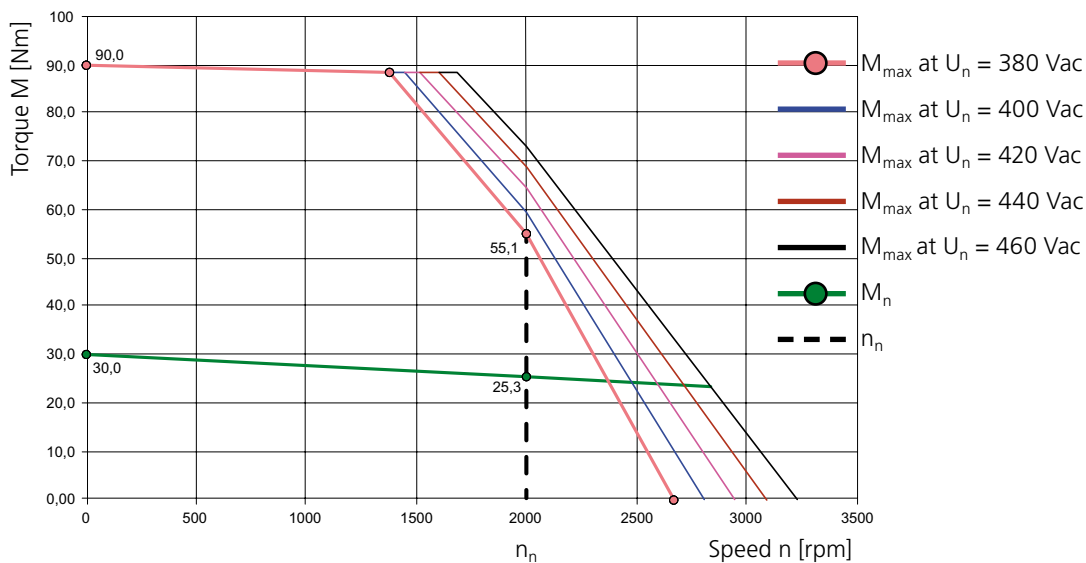

### LSN-158-3800-20-560

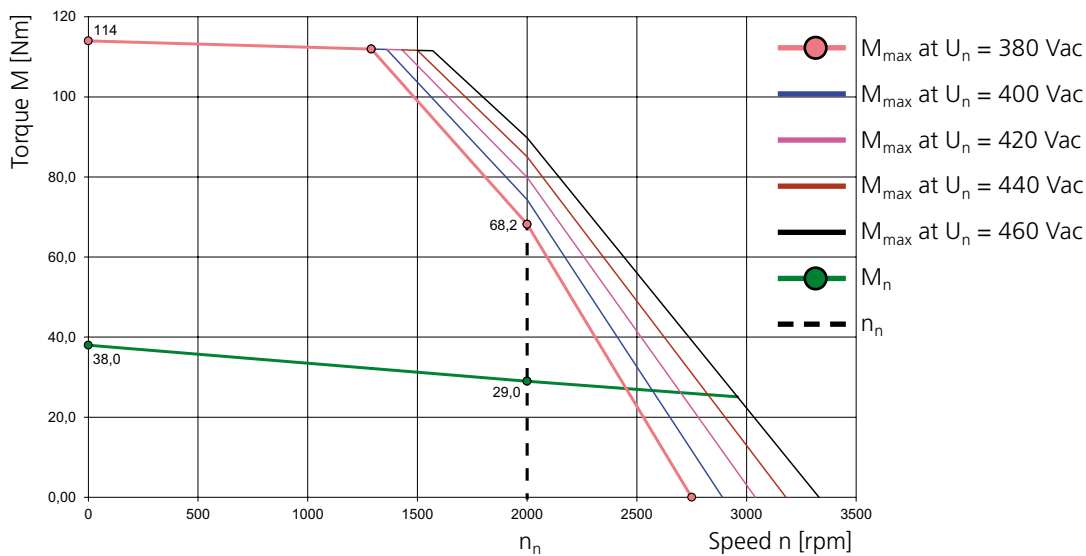

### LSN-158-4400-20-560

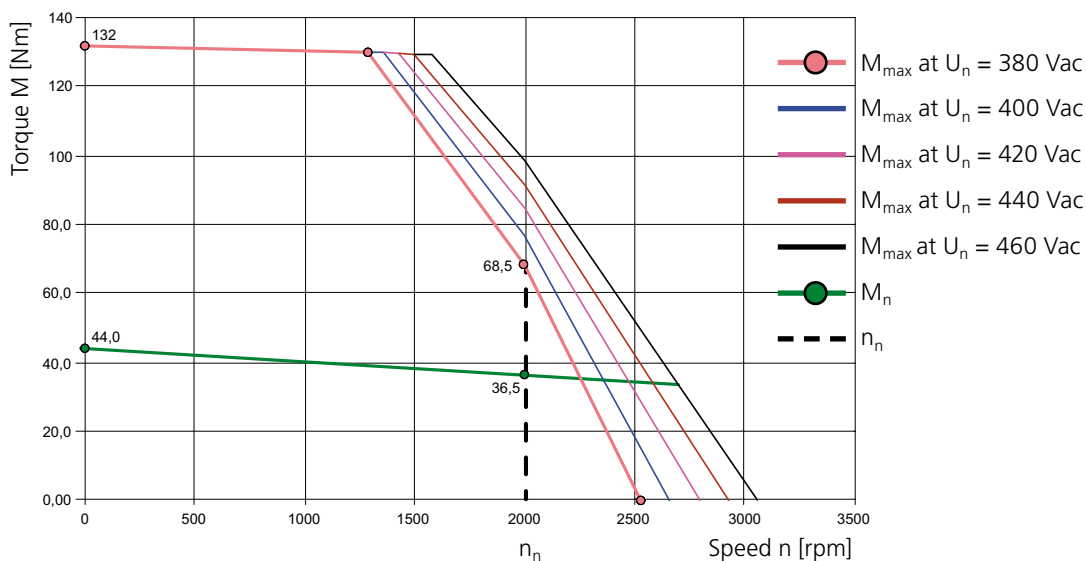



2.24 Motor type:  
LSN-158  
( $U_{dc} = 560 \text{ V}$ ,  
 $n_n = 3000 \text{ rpm}$ )

2

### 2.24.1 Dimensional sketch and technical data

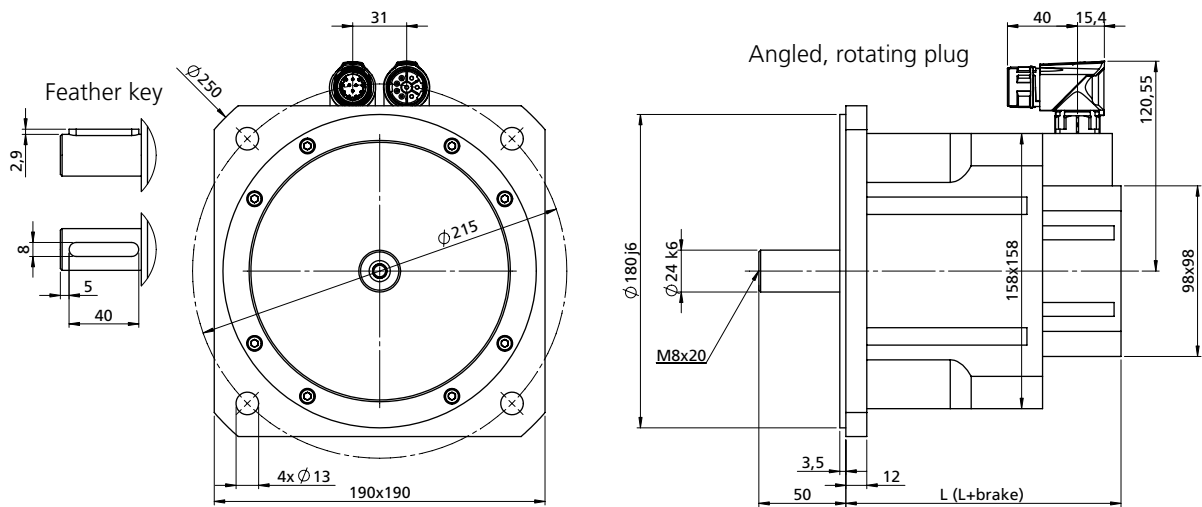

Motor type	L with resolver xR [mm]	L+brake with resolver xR [mm]	L with opt. encoder G12.xy [mm]	L+brake with opt. encoder G12.xy [mm]
LSN-158-1800	158	222	In preparation	In preparation
LSN-158-2400	183	247	In preparation	In preparation
LSN-158-3000	208	272	In preparation	In preparation
LSN-158-3800	233	297	In preparation	In preparation
LSN-158-4400	258	322	In preparation	In preparation

Motor type	L with opt. encoder G6.1x [mm]	L+brake with opt. encoder G6.1x [mm]	L with opt. encoder G6.2x [mm]	L+brake with opt. encoder G6.2x [mm]	L with opt. encoder G6.3x [mm]	L+brake with opt. encoder G6.3x [mm]
LSN-158-1800	161	In preparation	158	In preparation	In preparation	158
LSN-158-2400	186	In preparation	183	In preparation	In preparation	183
LSN-158-3000	211	In preparation	208	In preparation	In preparation	208
LSN-158-3800	236	In preparation	233	In preparation	In preparation	233
LSN-158-4400	261	In preparation	258	In preparation	In preparation	258

Table: Overview of motor lengths – for overview of encoder types see section 5.1



Technical data <sup>1)</sup>	Sym- bol	LSN-158- 1800-30	LSN-158- 2400-30	LSN-158- 3000-30	LSN-158- 3800-30	LSN-158- 4400-30
Rated speed	$n_n$	3000 rpm	3000 rpm	3000 rpm	3000 rpm	3000 rpm
Rated frequency	$f_N$	250 Hz	250 Hz	250 Hz	250 Hz	250 Hz
DC link voltage (controller)	$U_{dc}$	560 V	560 V	560 V	560 V	560 V
Rated voltage	$U_n$	380 V	380 V	380 V	380 V	380 V
Rated torque	$M_n$	13.00 Nm	17.00 Nm	21.00 Nm	25.00 Nm	30.00 Nm
Rated current	$I_n$	11.00 A	13.80 A	16.20 A	19.70 A	24.40 A
Rated power	$P$	4.08 kW	5.34 kW	6.60 kW	7.85 kW	9.42 kW
Stall torque	$M_0$	18.0 Nm	24.0 Nm	30.0 Nm	38.0 Nm	44.0 Nm
Stall current	$I_0$	12.2 A	15.3 A	17.8 A	23.9 A	28.3 A
Maximum permissible torque	$M_{max}$	51.0 Nm	72.0 Nm	90.0 Nm	114.0 Nm	132.0 Nm
Maximum permissible current	$I_{max}$	45.0 A	60.0 A	64.0 A	93.0 A	102.0 A
Maximum permissible speed	$n_{max}$	6000 rpm	6000 rpm	6000 rpm	6000 rpm	6000 rpm
Voltage constant	$K_E$	89.0 V/ 1000 rpm	95.0 V/ 1000 rpm	102.0 V/ 1000 rpm	96.0 V/ 1000 rpm	94.0 V/ 1000 rpm
Torque constant	$K_T$	1.47 Nm/A	1.57 Nm/A	1.69 Nm/A	1.59 Nm/A	1.55 Nm/A
Winding resistance (2 phases)	$R_{2ph}$	0.62 $\Omega$	0.41 $\Omega$	0.33 $\Omega$	0.25 $\Omega$	0.19 $\Omega$
Winding inductance (2 phases)	$L_{2ph}$	7.2 mH	5.5 mH	4.7 mH	3.5 mH	2.8 mH
No load speed	$n_0$	4260 rpm	4000 rpm	3720 rpm	3950 rpm	4040 rpm
Electrical time constant	$T_{el}$	11.6 ms	13.4 ms	14.2 ms	14.0 ms	14.5 ms
Thermal time constant	$T_{th}$	42 min.	47 min.	52 min.	57 min.	62 min.
Moment of inertia of the motor	$J$	0.00185 kgm <sup>2</sup>	0.00256 kgm <sup>2</sup>	0.00327 kgm <sup>2</sup>	0.00399 kgm <sup>2</sup>	0.00470 kgm <sup>2</sup>
Mass	$m$	10.1 kg	12.8 kg	15.5 kg	18.3 kg	21.0 kg

#### Brake (optional)

Rated voltage	$U_N$	24 V $\pm$ 10 %
Rated current at 20 °C for venting	$I_N$	1.10 A
Permissible maximum speed	$n_{max}$	10000 rpm
Permissible friction energy	$W_R$	2.90 x 10 <sup>6</sup> Ws
Mass moment of inertia	$J_B$	0.000556 kgm <sup>2</sup>
Mass	$m$	2.85 kg
Braking torque	$M_H$	36.00 Nm

#### Additional technical data

Protection	IP64, optionally IP65 or IP67
Electrical connections	Intercontec plug (x2)
Thermal motor protection	PTC, optionally thermoswitch 140° C, KTY or NTC
Nominal data	to EN 60034 <sup>-1</sup> , $T_A = 40^\circ \text{C}$ , $T_{over} = 110 \text{K}$ , flange temperature $\leq 65^\circ \text{C}$
Servo amplifier	Stator windings for DC link voltage $U_{dc} = 320 \text{V}$ or 560 VDC, other voltages optional
Flange/shaft	to DIN 42955 N, optionally R

1) All values with a tolerance of  $\pm 10\%$ . Other windings/rated speeds possible. Subject to technical change without notice.

## 2.24.2 Characteristics

Explanations of characteristics:

The characteristic  $M_{\max}$  describes the maximum possible short-time torque at corresponding speed. It is important for dynamic processes.

The characteristic  $M_n$  indicates the thermally permissible rated torque.

The characteristics are limited by the respective maximum permissible speed  $n_{\max}$  (for  $n_{\max}$  refer to the "Technical data" table).

2

### LSN-158-1800-30-560

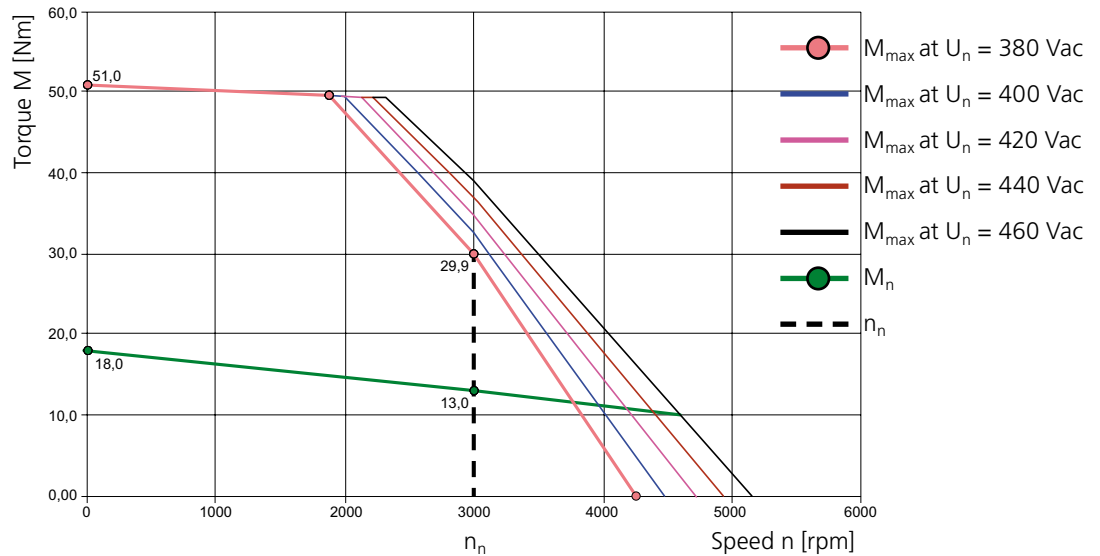

### LSN-158-2400-30-560

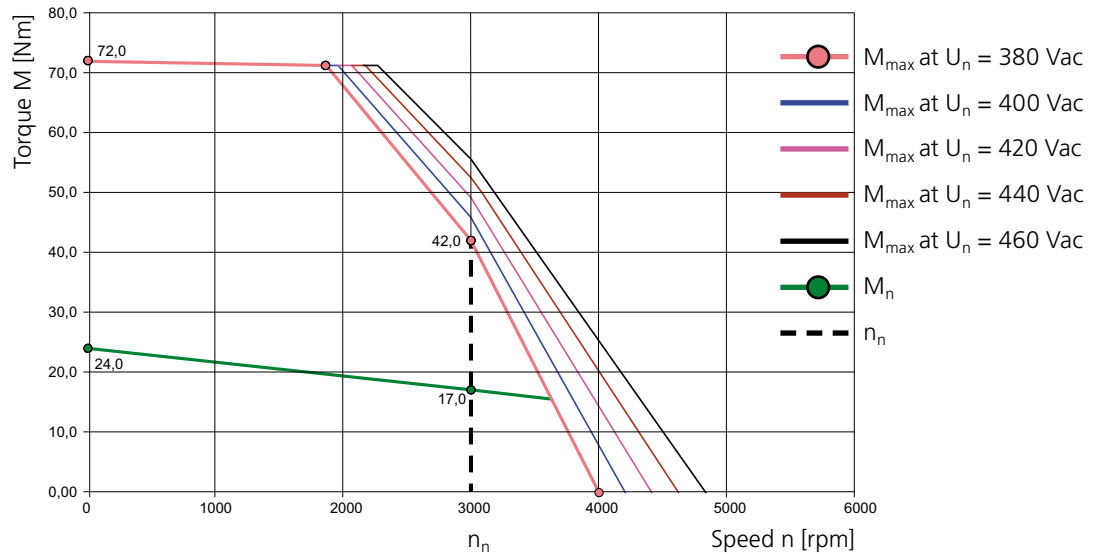

### LSN-158-3000-30-560

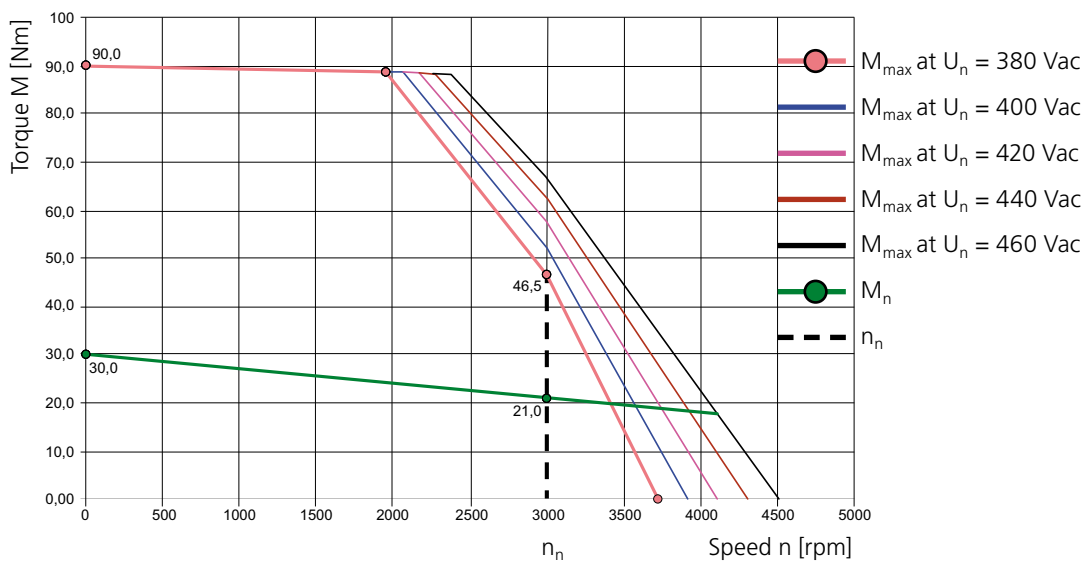

### LSN-158-3800-30-560

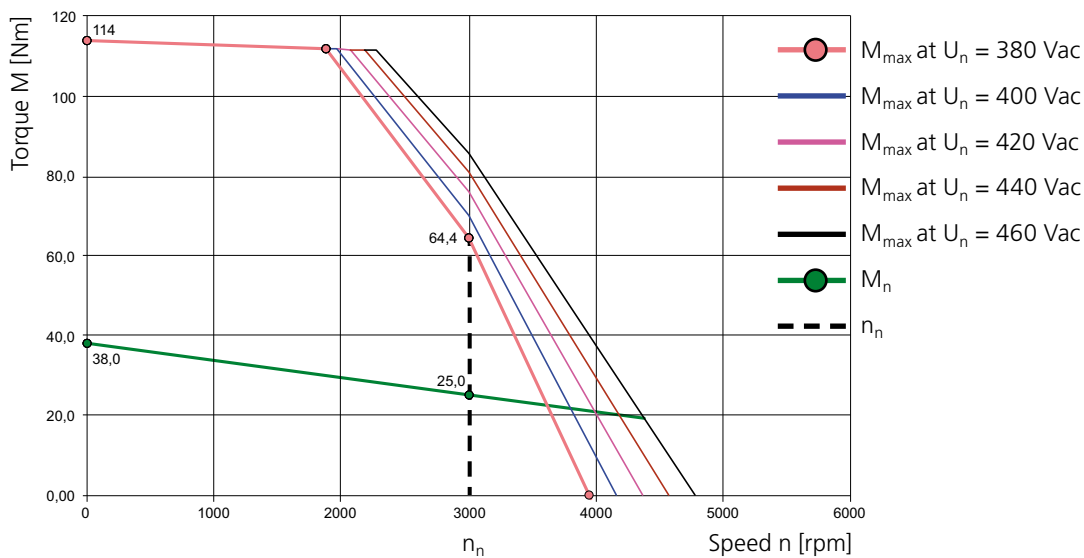

### LSN-158-4400-30-560

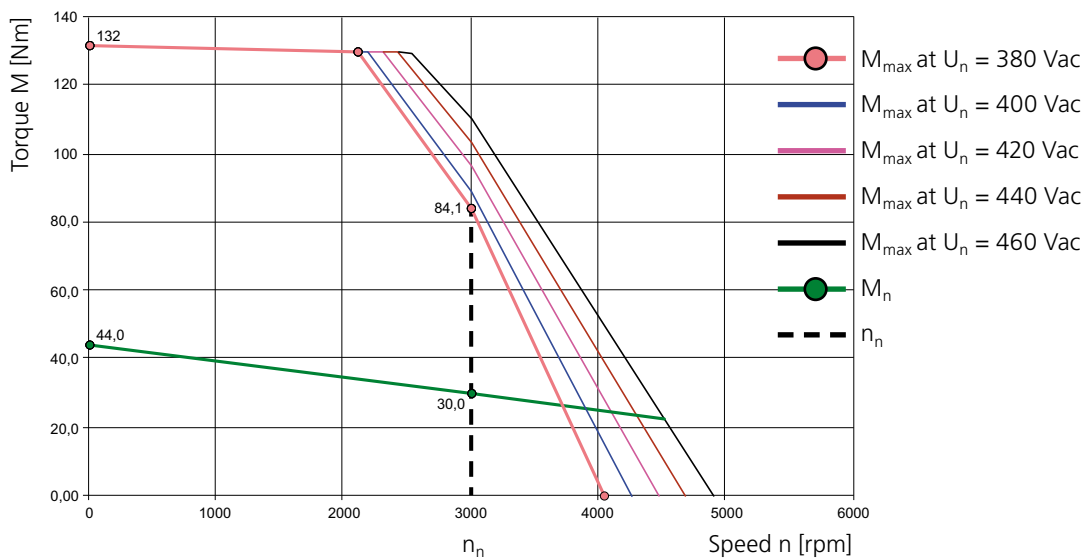

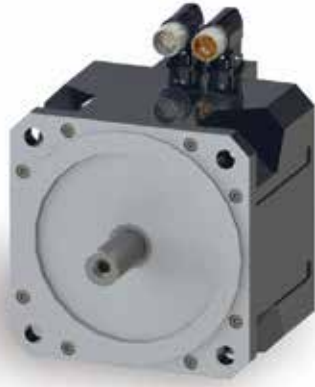

2.25 Motor type:  
LSN-190  
( $U_{dc} = 560 \text{ V}$ ,  
 $n_n = 2000 \text{ rpm}/1000 \text{ rpm}$ )

### 2.25.1 Dimensional sketch and technical data

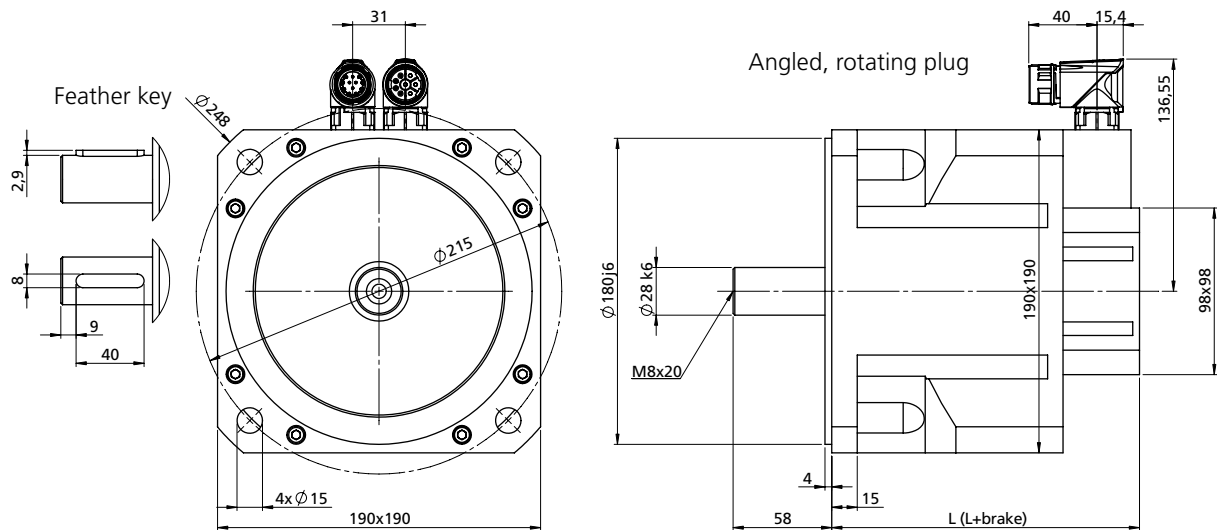

Motor type	L with resolver xR [mm]	L+brake with resolver xR [mm]	L with opt. encoder G12.xy [mm]	L+brake with opt. encoder G12.xy [mm]
LSN-190-3000	181	240	In preparation	In preparation
LSN-190-4000	211	270	In preparation	In preparation
LSN-190-5000	241	300	In preparation	In preparation
LSN-190-6000	271	330	In preparation	In preparation

Motor type	L with opt. encoder G6.1x [mm]	L+brake with opt. encoder G6.1x [mm]	L with opt. encoder G6.2x [mm]	L+brake with opt. encoder G6.2x [mm]	L with opt. encoder G6.3x [mm]	L+brake with opt. encoder G6.3x [mm]
LSN-190-3000	In preparation	In preparation	In preparation	In preparation	In preparation	In preparation
LSN-190-4000	In preparation	In preparation	In preparation	In preparation	In preparation	In preparation
LSN-190-5000	In preparation	In preparation	In preparation	In preparation	In preparation	In preparation
LSN-190-6000	In preparation	In preparation	In preparation	In preparation	In preparation	In preparation

Table: Overview of motor lengths – for overview of encoder types see section 5.1

Technical data <sup>1)</sup>	Symbol	LSN-190-3000-20	LSN-190-4000-20	LSN-190-5000-20	LSN-190-6000-10
Rated speed	$n_n$	2000 rpm	2000 rpm	2000 rpm	1000 rpm
Rated frequency	$f_N$	166.67 Hz	166.67 Hz	166.67 Hz	83.33 Hz
DC link voltage (controller)	$U_{dc}$	560 V	560 V	560 V	560 V
Rated voltage	$U_n$	380 V	380 V	380 V	380 V
Rated torque	$M_n$	26.10 Nm	32.80 Nm	40.40 Nm	54.00 Nm
Rated current	$I_n$	13.20 A	15.40 A	21.80 A	14.60 A
Rated power	P	5.47 kW	6.87 kW	8.46 kW	5.65 kW
Stall torque	$M_0$	30.0 Nm	40.0 Nm	50.0 Nm	60.0 Nm
Stall current	$I_0$	13.0 A	16.7 A	22.7 A	15.8 A
Maximum permissible torque	$M_{max}$	85.0 Nm	120.0 Nm	150.0 Nm	180.0 Nm
Maximum permissible current	$I_{max}$	46.0 A	59.0 A	79.0 A	51.0 A
Maximum permissible speed	$n_{max}$	6000 rpm	6000 rpm	6000 rpm	6000 rpm
Voltage constant	$K_E$	139.0 V/1000 rpm	145.0 V/1000 rpm	133.0 V/1000 rpm	241.0 V/1000 rpm
Torque constant	$K_T$	2.30 Nm/A	2.40 Nm/A	2.20 Nm/A	4.00 Nm/A
Winding resistance (2 phases)	$R_{2ph}$	0.64 $\Omega$	0.43 $\Omega$	0.25 $\Omega$	0.62 $\Omega$
Winding inductance (2 phases)	$L_{2ph}$	10.1 mH	7.8 mH	4.9 mH	13.0 mH
No load speed	$n_0$	2730 rpm	2620 rpm	2850 rpm	1570 rpm
Electrical time constant	$T_{el}$	15.8 ms	18.1 ms	19.6 ms	21.0 ms
Thermal time constant	$T_{th}$	80 min.	90 min.	100 min.	108 min.
Moment of inertia of the motor	J	0.00495 kgm <sup>2</sup>	0.0069 kgm <sup>2</sup>	0.0088 kgm <sup>2</sup>	0.0107 kgm <sup>2</sup>
Mass	m	16.50 kg	21.50 kg	26.5 kg	31.5 kg

#### Brake (optional)

Rated voltage	$U_N$	24 V $\pm$ 10 %
Rated current at 20 °C for venting	$I_N$	1.10 A
Permissible maximum speed	$n_{max}$	8000 rpm
Permissible friction energy	$W_R$	6.20 x 10 <sup>6</sup> Ws
Mass moment of inertia	$J_B$	0.0016 kgm <sup>2</sup>
Mass	m	3.25 kg
Braking torque	$M_H$	36.00 Nm

#### Additional technical data

Protection	IP64, optionally IP65 or IP67
Electrical connections	Intercontec plug (x2)
Thermal motor protection	PTC, optionally thermoswitch 140° C, KTY or NTC
Nominal data	to EN 60034-1, $T_A = 40^\circ \text{C}$ , $T_{over} = 110 \text{K}$ , flange temperature $\leq 65^\circ \text{C}$
Servo amplifier	Stator windings for DC link voltage $U_{dc} = 320 \text{V}$ or 560 VDC, other voltages optional
Flange/shaft	to DIN 42955 N, optionally R

<sup>1)</sup> All values with a tolerance of  $\pm 10\%$ . Other windings/rated speeds possible. Subject to technical change without notice.

## 2.25.2 Characteristics

Explanations of characteristics:

The characteristic  $M_{\max}$  describes the maximum possible short-time torque at corresponding speed. It is important for dynamic processes.

The characteristic  $M_n$  indicates the thermally permissible rated torque.

The characteristics are limited by the respective maximum permissible speed  $n_{\max}$  (for  $n_{\max}$  refer to the "Technical data" table).

2

### LSN-190-3000-20-560

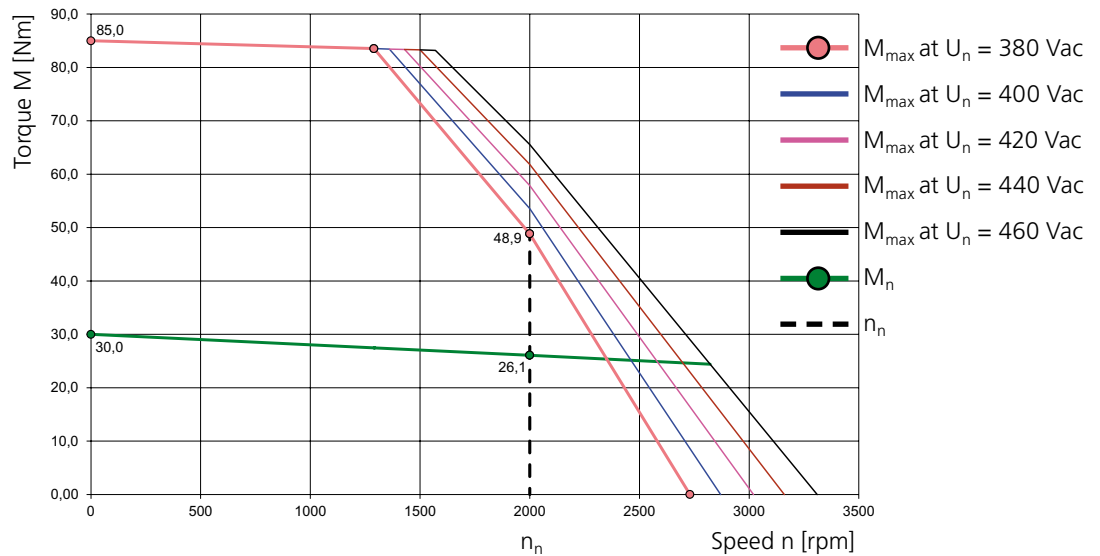

### LSN-190-4000-20-560

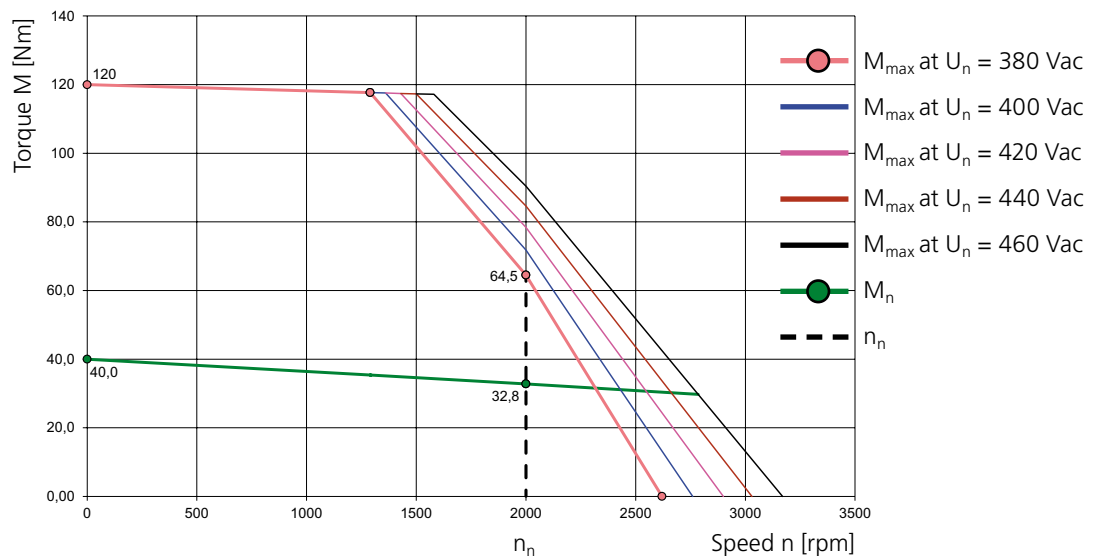

### LSN-190-5000-20-560

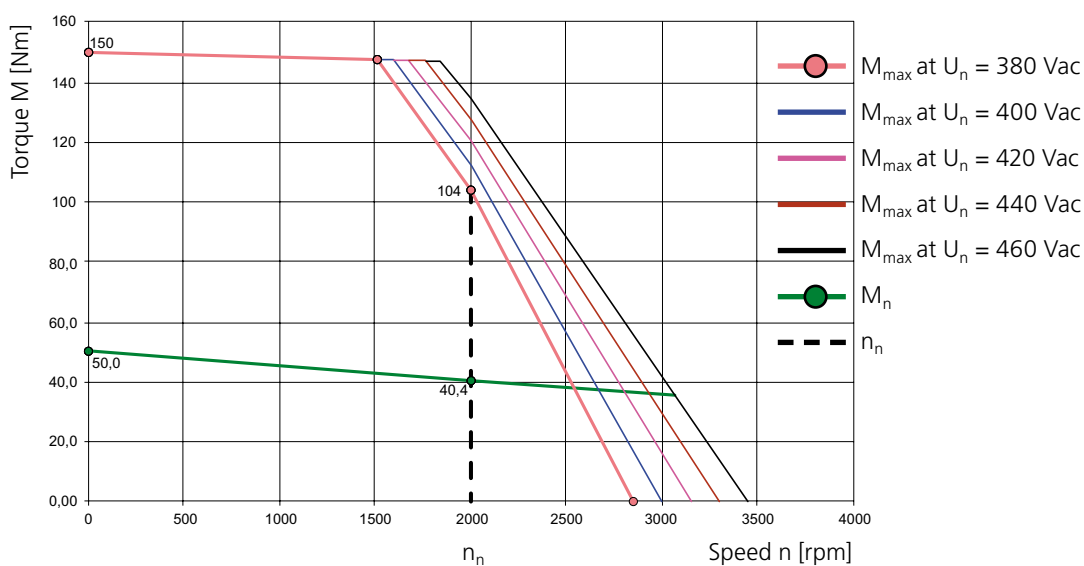

### LSN-190-6000-10-560

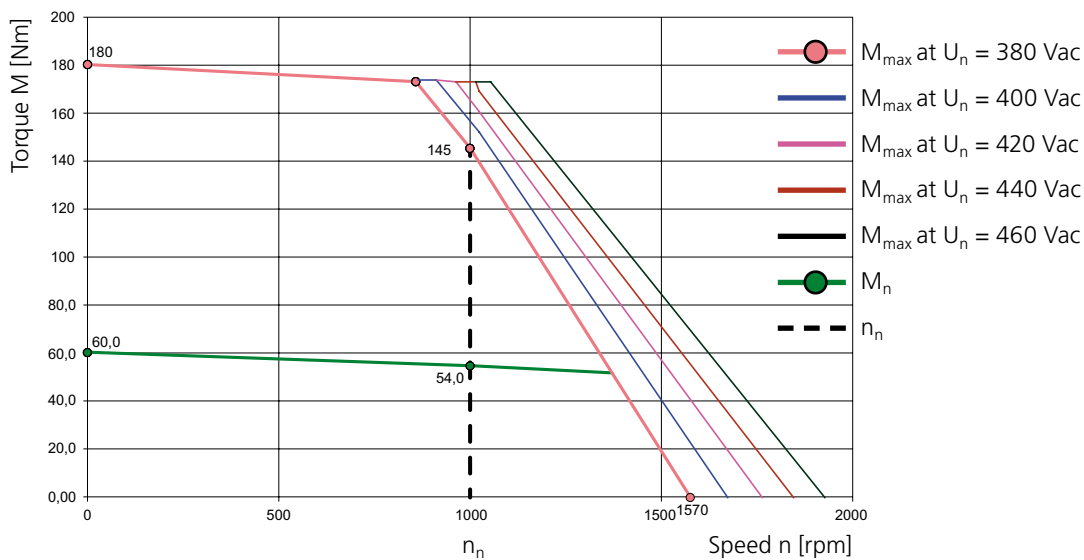

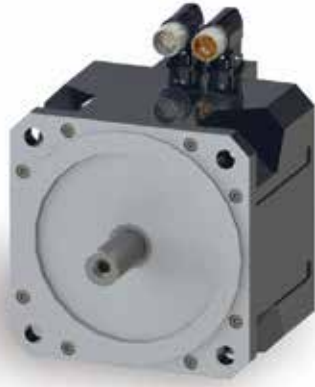

2.26 Motor type:  
LSN-190  
( $U_{dc} = 560 \text{ V}$ ,  
 $n_n = 3000 \text{ rpm}/2500 \text{ rpm}$ )

### 2.26.1 Dimensional sketch and technical data

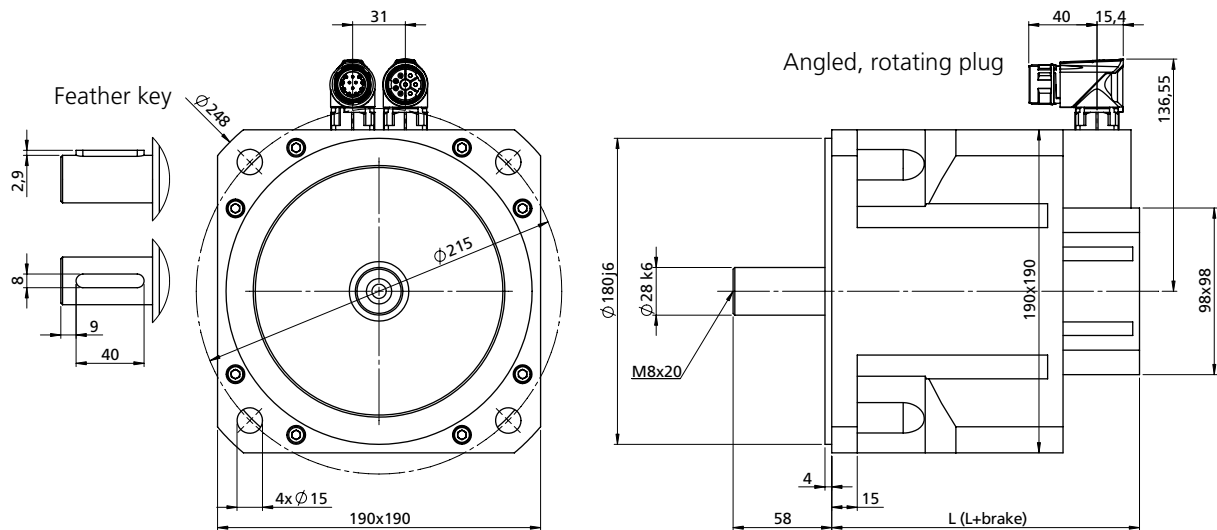

Motor type	L with resolver xR [mm]	L+brake with resolver xR [mm]	L with opt. encoder G12.xy [mm]	L+brake with opt. encoder G12.xy [mm]
LSN-190-3000	181	240	In preparation	In preparation
LSN-190-4000	211	270	In preparation	In preparation
LSN-190-5000	241	300	In preparation	In preparation
LSN-190-6000	271	330	In preparation	In preparation

Motor type	L with opt. encoder G6.1x [mm]	L+brake with opt. encoder G6.1x [mm]	L with opt. encoder G6.2x [mm]	L+brake with opt. encoder G6.2x [mm]	L with opt. encoder G6.3x [mm]	L+brake with opt. encoder G6.3x [mm]
LSN-190-3000	In preparation	In preparation	In preparation	In preparation	In preparation	In preparation
LSN-190-4000	In preparation	In preparation	In preparation	In preparation	In preparation	In preparation
LSN-190-5000	In preparation	In preparation	In preparation	In preparation	In preparation	In preparation
LSN-190-6000	In preparation	In preparation	In preparation	In preparation	In preparation	In preparation

Table: Overview of motor lengths – for overview of encoder types see section 5.1



Technical data <sup>1)</sup>	Symbol	LSN-190-3000-30	LSN-190-4000-30	LSN-190-5000-30	LSN-190-6000-25
Rated speed	$n_n$	3000 rpm	3000 rpm	3000 rpm	2500 rpm
Rated frequency	$f_N$	250 Hz	250 Hz	250 Hz	208.33 Hz
DC link voltage (controller)	$U_{dc}$	560 V	560 V	560 V	560 V
Rated voltage	$U_n$	380 V	380 V	380 V	380 V
Rated torque	$M_n$	23.00 Nm	25.00 Nm	30.00 Nm	36.20 Nm
Rated current	$I_n$	15.50 A	20.10 A	24.40 A	20.70 A
Rated power	$P$	7.23 kW	7.85 kW	9.42 kW	9.48 kW
Stall torque	$M_0$	30.0 Nm	40.0 Nm	50.0 Nm	60.0 Nm
Stall current	$I_0$	16.3 A	26.3 A	31.5 A	30.0 A
Maximum permissible torque	$M_{max}$	85.0 Nm	120.0 Nm	150.0 Nm	180.0 Nm
Maximum permissible current	$I_{max}$	58.0 A	90.0 A	109.0 A	102.0 A
Maximum permissible speed	$n_{max}$	6000 rpm	6000 rpm	6000 rpm	6000 rpm
Voltage constant	$K_E$	111.0 V/1000 rpm	92.0 V/1000 rpm	96.0 V/1000 rpm	121.0 V/1000 rpm
Torque constant	$K_T$	1.84 Nm/A	1.52 Nm/A	1.59 Nm/A	2.00 Nm/A
Winding resistance (2 phases)	$R_{2ph}$	0.41 $\Omega$	0.17 $\Omega$	0.13 $\Omega$	0.16 $\Omega$
Winding inductance (2 phases)	$L_{2ph}$	6.4 mH	3.1 mH	2.6 mH	3.3 mH
No load speed	$n_0$	3420 rpm	4130 rpm	3950 rpm	3140 rpm
Electrical time constant	$T_{el}$	15.6 ms	18.2 ms	20.0 ms	21.0 ms
Thermal time constant	$T_{th}$	80 min.	90 min.	100 min.	108 min.
Moment of inertia of the motor	$J$	0.00495 kgm <sup>2</sup>	0.0069 kgm <sup>2</sup>	0.0088 kgm <sup>2</sup>	0.0107 kgm <sup>2</sup>
Mass	$m$	16.50 kg	21.50 kg	26.5 kg	31.5 kg

#### Brake (optional)

Rated voltage	$U_N$	24 V $\pm$ 10 %
Rated current at 20 °C for venting	$I_N$	1.10 A
Permissible maximum speed	$n_{max}$	8000 rpm
Permissible friction energy	$W_R$	6.20 x 10 <sup>6</sup> Ws
Mass moment of inertia	$J_B$	0.0016 kgm <sup>2</sup>
Mass	$m$	3.25 kg
Braking torque	$M_H$	36.00 Nm

#### Additional technical data

Protection	IP64, optionally IP65 or IP67
Electrical connections	Intercontec plug (x2)
Thermal motor protection	PTC, optionally thermoswitch 140° C, KTY or NTC
Nominal data	to EN 60034-1, $T_A = 40^\circ \text{C}$ , $T_{over} = 110 \text{K}$ , flange temperature $\leq 65^\circ \text{C}$
Servo amplifier	Stator windings for DC link voltage $U_{dc} = 320 \text{V}$ or 560 VDC, other voltages optional
Flange/shaft	to DIN 42955 N, optionally R

<sup>1)</sup> All values with a tolerance of  $\pm 10\%$ . Other windings/rated speeds possible. Subject to technical change without notice.

## 2.26.2 Characteristics

Explanations of characteristics:

The characteristic  $M_{\max}$  describes the maximum possible short-time torque at corresponding speed. It is important for dynamic processes.

The characteristic  $M_n$  indicates the thermally permissible rated torque.

The characteristics are limited by the respective maximum permissible speed  $n_{\max}$  (for  $n_{\max}$  refer to the "Technical data" table).

2

### LSN-190-3000-30-560

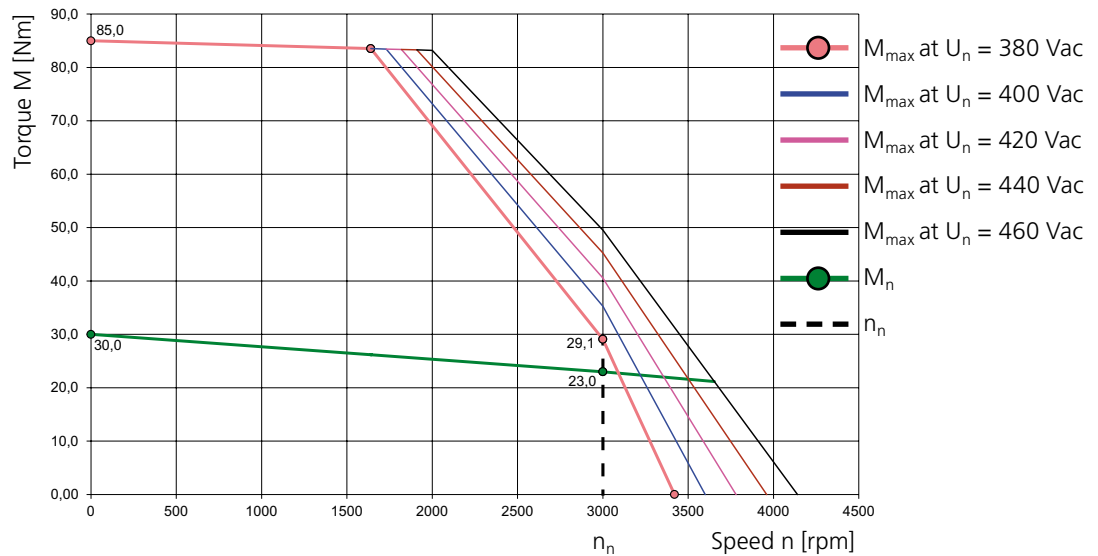

### LSN-190-4000-30-560

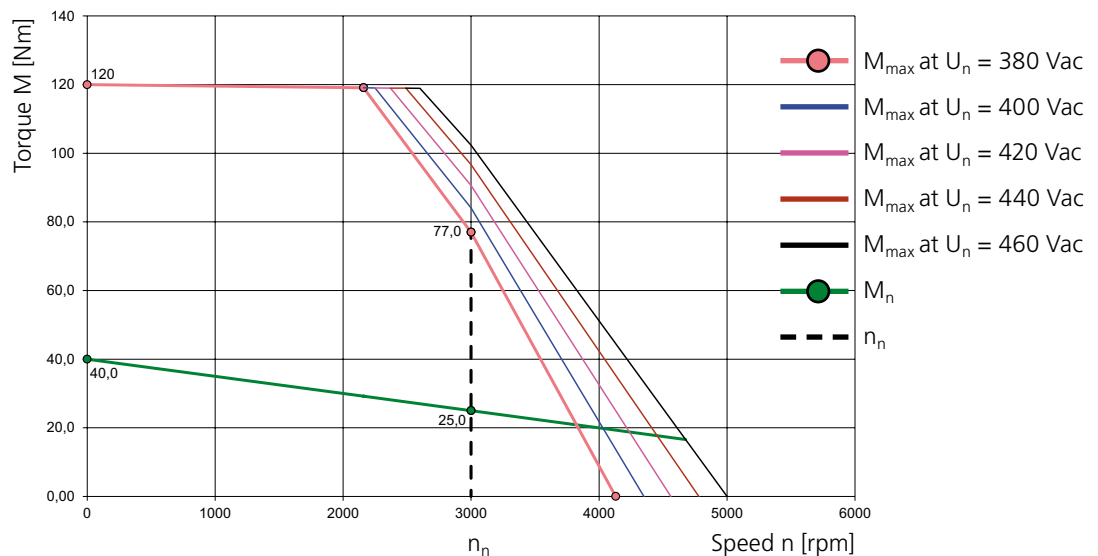

### LSN-190-5000-30-560

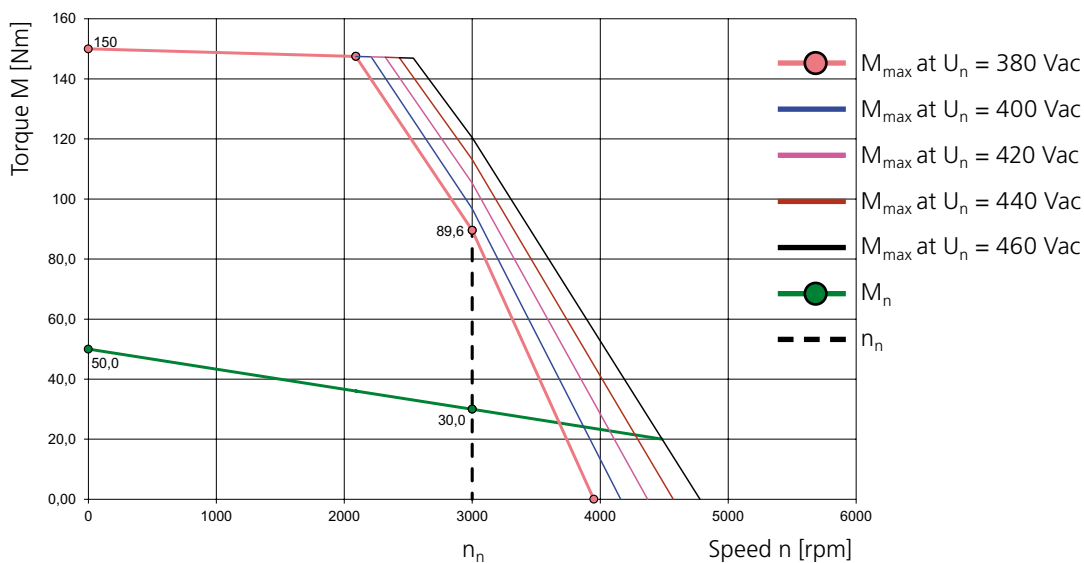

### LSN-190-6000-25-560

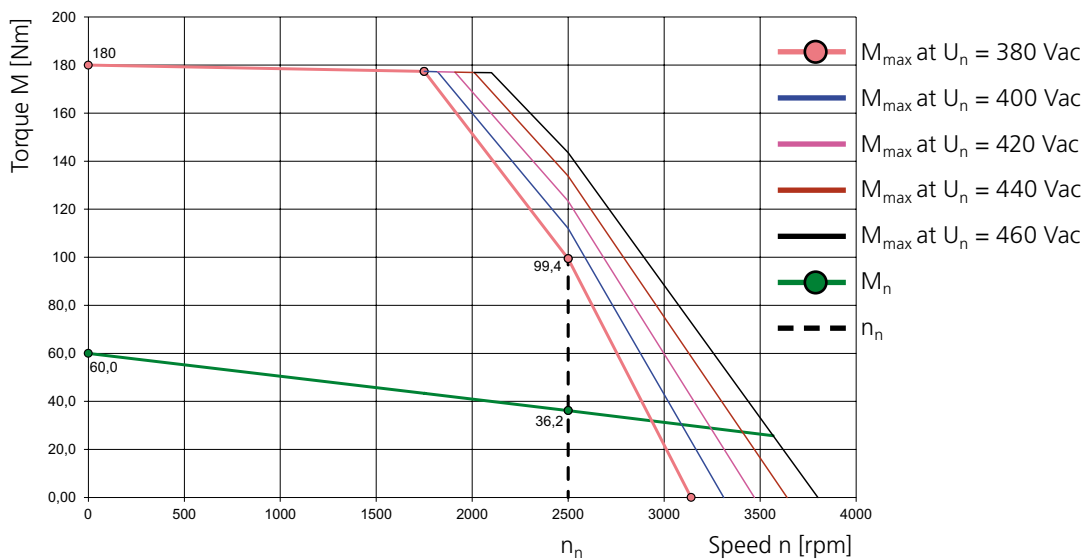

Space for notes

A large grid of graph paper for taking notes, consisting of 20 columns and 30 rows of small squares.

Space for notes

Space for notes

2

A large grid of graph paper for taking notes, consisting of 20 columns and 30 rows of small squares.



## 3 The LST servomotor – the versatile one

### 3.1 Applications

LTI synchronous servomotors are brushless three-phase-current motors for high-end servo applications, available in all speed and voltage variants. They are particularly suitable for positioning tasks on machine tools, industrial robots, transfer lines, etc., as well as for applications entailing high dynamic and stability demands.

The standard versions of our servomotors are equipped to handle a wide range of applications. Available options include a holding brake, IP65 protection, a wide variety of temperature monitors, cable tails, high-resolution SSI encoders and Hiperface encoder, through to custom flanges and special shafts. We also optionally offer our servomotors in EX (explosion-proof) variants. Contact our drive specialists for details.

The LST series in the rated torque range ( $M_0$ ) from 0.1 to 115 Nm (externally cooled up to 145 Nm) features a conventional (distributed) winding technique. It combines all the advantages of the 6-pole synchronous servomotor in the classic design.

### 3.2 Features of LST servomotors

- Well suited to speeds up to 9000 rpm
- High overload capacity
- Increased rotor moment of inertia
- High degree of synchronism
- Wide variety of sizes

### 3.3 Declaration of conformity for LST servomotors

#### EG-Konformitätserklärung



##### EC Declaration of Conformity

Der Hersteller  
*The manufacturer* LTi DRIVES GmbH  
Gewerbestraße 5-9  
35633 Lahnau

erklärt hiermit, dass die folgenden Produkte  
*declares that the following products*

Produktbezeichnung:  
*Product designation:* Synchron-Servomotor  
*Synchronous Servomotor*

Produkttypen:  
*Product types:* LSH, LST, LSN  
*LSH, LST, LSN*

den Sicherheitsbestimmungen der nachstehenden EG-Richtlinie entsprechen:  
*comply with the essential requirements of the following EC Directive:*

2006/95/EG  
*2006/95/EC* [Niederspannungsrichtlinie]  
*[Low Voltage Directive]*

und dass folgende angeführte harmonisierte Norm angewandt wurde:  
*and that the following harmonised standard has been applied:*

EN 60034-1:2004  
Drehende elektrische Maschinen - Teil 1: Bemessung und Betriebsverhalten (IEC 60034-1:2004)  
*Rotating electrical machines - Part 1: Rating and performance (IEC 60034-1:2004)*

EN 60034-5:2001+A1:2007  
Drehende elektrische Maschinen - Teil 5: Schutzarten aufgrund der Gesamtkonstruktion von drehenden elektrischen Maschinen (IP-Code) - Einteilung (IEC 60034-5:2000)  
*Rotating electrical machines - Part 5: Degrees of protection provided by the integral design of rotating electrical machines (IP code); Classification (IEC 60034-5:2000)*

EN 60034-6:1993  
Drehende elektrische Maschinen - Teil 6: Einteilung der Kühlverfahren (IC-Code) (IEC 60034-6:1991)  
*Rotating electrical machines - Part 6: Methods of cooling (IC-Code) (IEC 60034-6:1991)*

EN 60034-9:2005+A1:2007  
Drehende elektrische Maschinen - Teil 9: Geräuschgrenzwerte (IEC 60034-9:2003)  
*Rotating electrical machines - Part 9: Noise limits (IEC 60034-9:2003)*

Jahr der CE-Kennzeichnung / *Year of CE-marking:* 2005

Unterschrift / *signature*

Name / *name:*

Stellung / *position:*

Datum / *date:*

  
Dr. Josef Wiesing

Geschäftsführer / *Managing Director*

04.12.2012

Dokument: 0970.0DK.2-04



### 3.4 Properties of LST servomotors

Machine type	Permanently excited 3-phase-current synchronous servomotor
Magnet material	Neodymium-iron-boron
Design (DIN 42948)	B5, V1, V3
Protection (DIN 40050)	IP64, IP54 to EN 60034-5 (circulating machines), IP65 optionally available
Insulating material class	Insulating material class F to VDE0530 , winding overtemperature $\Delta t = 100 \text{ }^\circ\text{C}$ , ambient temperature $t_u = -20 \text{ }^\circ\text{C}$ to $+40 \text{ }^\circ\text{C}$ , no condensation!!!
Coating	RAL 9005 (matt black)
Shaft end on A-side	Smooth shaft (feather key and feather key way DIN 6885, tolerance band k6 as option)
Smooth running, coaxiality and axial run-out to DIN 42955	Tolerance N (normal), tolerance R (reduced) on request
Thermal motor monitoring	DIN-PTC in a stator winding
Torque load	To prevent thermal motor overloading, the effective load moment at medium RPM must not be above curve S1.

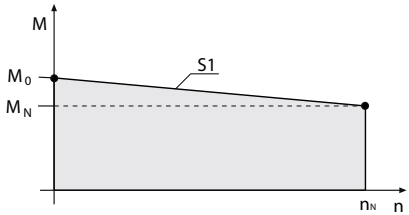

$$M_{\text{eff}} = \sqrt{\frac{S (M_n^2 \times t_n)}{t_{\text{ges}}}} \quad \bar{n} = \frac{S (n_n \times t_n)}{t_{\text{ges}}}$$

Maximum pulse torque	Typically 2 to 4 times rated torque for max. 0.2 s, depending on controller assignment
Vibration severity to ISO 2373	Grade N, optionally R
Bearing service life	The average service life under nominal conditions ( $M_{\text{max}} \leq MN$ ) is 20,000 h
Termination mode of motor, thermistor and holding brake	via plug-in terminals
Termination mode of encoder system	Signal plug (mating plug not supplied)

### 3.5 Cooling

The specified nominal data relate to a maximum ambient temperature of 40 °C and mounting of the motor on an aluminium plate with a maximum temperature of 65 °C and installed at an altitude of max. 1,000 m above above MSL.

Minimum mounting area: 2.5 x area of motor flange

Thickness of mounting area: min. 10 mm

If the motor is mounted with insulation (no heat discharge via the flange) the nominal torque must be reduced. For installations above an altitude of > 1000 m above MSL the power output must be reduced by 1 % per 100 metres. The maximum installation altitude is 4000 metres. At ambient temperatures > 40 °C the power output must be reduced by 1 % per 1°C. The maximum ambient temperature is 50 °C.

## 3.6 Order codes for LTi LST series synchronous motors



### NOTE:

Preferential types are motors and options readily available ex stock. The wide range of variants means there are many combination options. The options marked with "\*" are preferential types and can be delivered more quickly.

LST-074 - 1 - 30-560/ D1 , B , P , X , K , S4 , G6.1S , W		Options (if available, sequence varying)	
<b>LTi synchronous motor series T</b>			
<b>Edge dimensions in mm (no flange dimensions)</b>	<b>037</b>	<b>127</b>	
	<b>050</b>	<b>158</b>	
	<b>074</b>	<b>190</b>	
	<b>097</b>	<b>220</b>	
<b>Length</b> (1... shortest motor type, 5... longest motor type) Dependent on the selected encoder.		<b>1</b>	
		<b>2</b>	
		<b>3</b>	
		<b>4</b>	
		<b>5</b>	
<b>Rated speed (x100) in rpm</b>		<b>30</b>	
		<b>45</b>	
		<b>60</b>	
<b>DC link voltage of controller (VDC)</b>		<b>24</b>	
		<b>48</b>	
		<b>320</b>	
		<b>560</b>	
<b>Options Thermal protection</b>	Thermoswitch / e.g. Klixon (DIN-PTC double basic insulation)	→	<b>T0</b>
	<b>Standard!</b>	→	<b>*T1</b>
	KTY84-130	→	<b>T4</b>
<b>Brake option</b>	Holding brake 24 VDC		<b>*B</b>
<b>Feather key option</b>	Feather key to DIN 6885, Sheet 1		<b>*P</b>
<b>Custom variant</b>	(e.g. special flange/shaft/housing/encoder, etc.)		<b>X</b>
<b>Cable option</b>	Cable, 1 m, open ends		<b>K</b>
<b>Termination option</b> (The A-side of the motor is the shaft face)	Angled plug, aligned to A-side		<b>S1</b>
	Angled plug, aligned to B-side		<b>S2</b>
	Angled plug, rotated 90°		<b>S3</b>
	Angled/rotating plugs		<b>*S4</b>
	from size LSN-127, angled, rotating plugs with raised body, rotation angle 270°		<b>S7</b>
<b>Options Encoder system</b> (For details see following table)	Resolver with 1 pole pair	→	<b>*1R</b>
	Resolver with 1 pole pair Safety	→	<b>1RY</b>
	Resolver with 3 pole pair	→	<b>3R</b>
	Resolver with 5 pole pair	→	<b>5R</b>
	Multi-turn absolute value encoder EQN 1325	→	<b>G3</b>
	Single-turn absolute value encoder ECN 1313	→	<b>G5</b>
	Single-turn absolute value encoder SRS 50	→	<b>G6.1S</b>
	Multi-turn absolute value encoder SRM 50	→	<b>G6.1M</b>
	Single-turn absolute value encoder SKS 36	→	<b>G6.2S</b>
	Single-turn absolute value encoder SKS 36 Safety	→	<b>G6.2SY</b>
	Multi-turn absolute value encoder SKM 36	→	<b>G6.2M</b>
	Multi-turn absolute value encoder SKM 36 Safety	→	<b>G6.2MY</b>
	Single-turn absolute value encoder ECN 1313	→	<b>G12.1S</b>
	Multi-turn absolute value encoder EQN 1325	→	<b>G12.1M</b>
	Single-turn absolute value encoder ECN 1113	→	<b>G12.2S</b>
	Multi-turn absolute value encoder EQN 1125	→	<b>G12.2M</b>
<b>Options Shaft packing ring</b>	Protection IP65 with shaft packing ring (approx.10mm longer)	→	<b>W</b>
	Protection IP65 without shaft packing ring	→	<b>V</b>

Table: Order codes for LST servomotors.

The options marked with "\*" are preferential types and can be delivered more quickly.

### 3.7 Composition of standard version

- Motor shaft smooth (no feather key)
- Resolver with 1 pole pair 1R
- IP64 to DIN 40050 except flange
- IP54 to DIN VDE0530-5 / EN60034-5 (circulating machines)
- Resolver plug straight, outgoing
- Power plug straight, outgoing
- Double basic insulation (winding and PTC) T1

Table: Definition of standard version

### 3.8 Ordering example for LST servomotors:

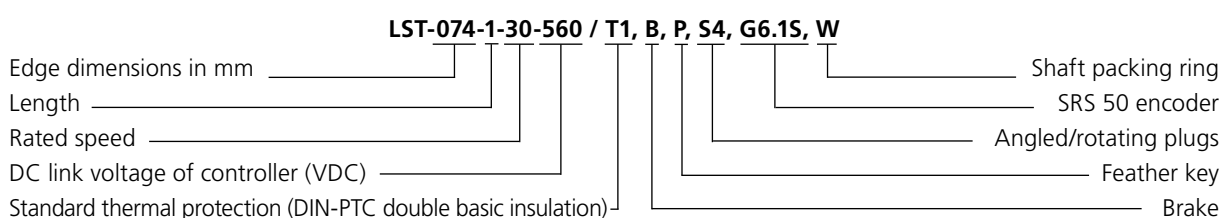

### 3.9 Ordering options

- Holding brake
- Various encoders
- Feather key to DIN 6885
- Special shaft/flange
- Special mechanism
- Servo gearing
- Cable tail
- UL approbation
- ATEX acceptance (please ask LTI-DRIVES specialist)
- etc.

## 3.10 Encoder system options



### NOTE:

Preferential types are motors and options readily available ex stock. The wide range of variants means there are many combination options. The options marked with "\*" are preferential types and can be delivered more quickly.

Ordering options	Description	Interface	Oscillations analog	Multi-turn resolution	Compatible with
*1R	Resolver with 1 pole pair	Analog	1	-	all LST
1RY	Resolver with 1 pole pair Safety	Analog	1	-	all LST <sup>1)</sup>
3R	Resolver with 3 pole pair	Analog	3	-	from LST-050
5R	Resolver with 5 pole pair	Analog	5	-	only LSN and LSH
G3	Multi-turn absolute value encoder EQN 1325	Analog and SSI	2048	12-bit	from LST-074
G5	Single-turn absolute value encoder ECN 1313	Analog and SSI	2048	-	from LST-074
G6.1S	Single-turn absolute value encoder SRS 50	Analog and Hiperface	1024	-	from LST-074
G6.1M	Multi-turn absolute value encoder SRM 50	Analog and Hiperface	1024	12-bit	from LST-074
G6.2S	Single-turn absolute value encoder SKS 36	Analog and Hiperface	128	-	from LST-050
G6.2SY	Single-turn absolute value encoder SKS 36 Safety	Analog and Hiperface	128	-	from LST-050 <sup>1)</sup> (ServoOne safety)
G6.2M	Multi-turn absolute value encoder SKM 36	Analog and Hiperface	128	12-bit	from LST-050
G6.2MY	Multi-turn absolute value encoder SKM 36 Safety	Analog and Hiperface	128	12-bit	from LST-050 <sup>1)</sup> (ServoOne safety)
G12.1S	Single-turn absolute value encoder ECN 1313	Analog and Endat 2.1	2048	-	from LST-074
G12.1M	Multi-turn absolute value encoder EQN 1325	Analog and Endat 2.1	2048	12-bit	from LST-074
G12.2S	Single-turn absolute value encoder ECN 1113	Analog and Endat 2.1	512	-	only LST-050
G12.2M	Multi-turn absolute value encoder EQN 1125	Analog and Endat 2.1	512	12-bit	only LST-050

Table: Explanation of encoder systems<sup>1)</sup> Suitable for safety applications to EN 62061 and IEC 61508 and to EN ISO 13849-1

Space for notes

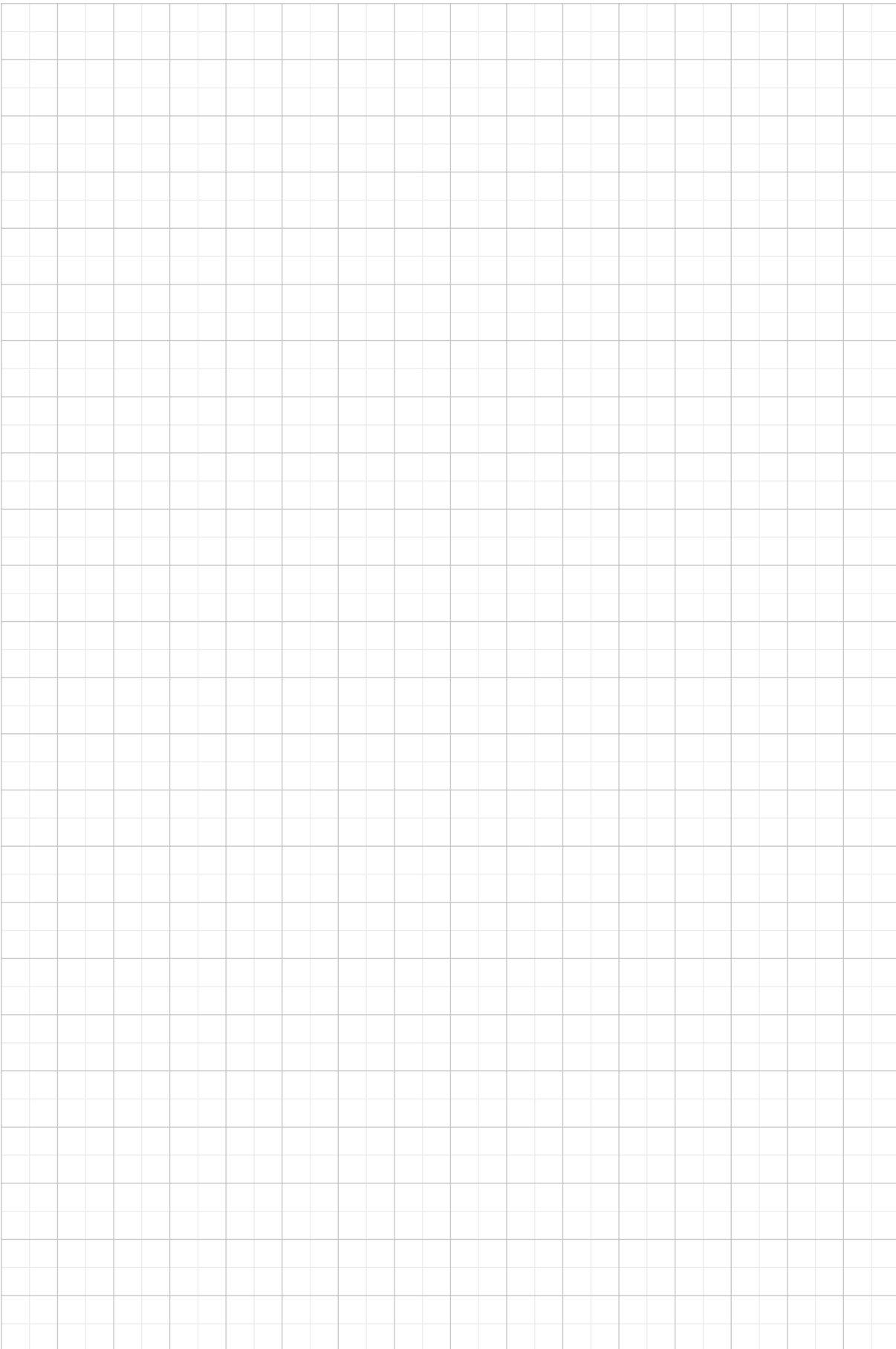
A large rectangular grid of small squares, intended for taking notes. The grid is composed of 20 columns and 30 rows of squares.

### 3.11 Typical M-n characteristic of LST servomotors

The characteristic indicates how the servomotor's speed responds to increasing load.

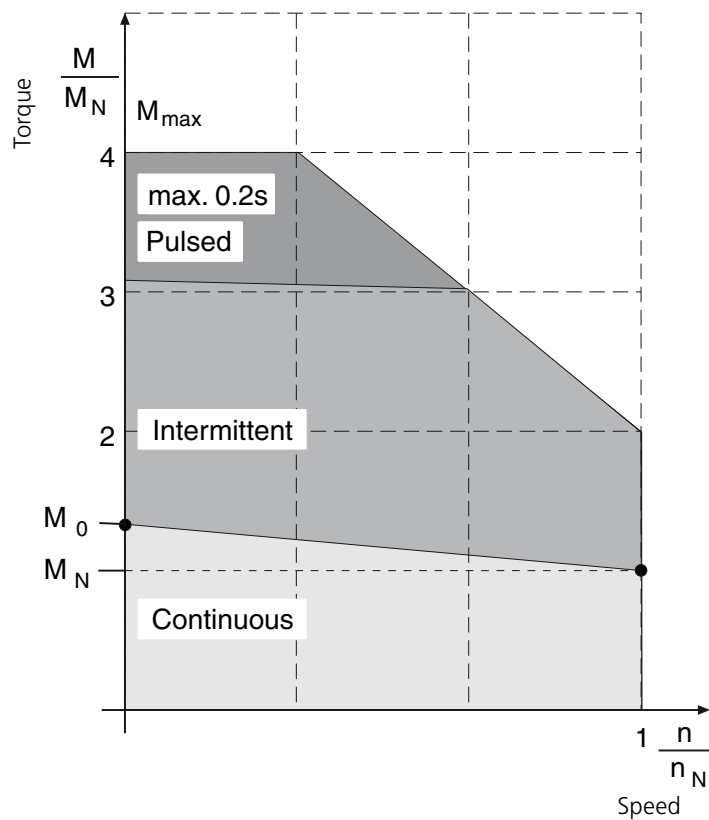

### M-n characteristic for synchronous motors

Term	Explanation
$n_N$ Rated speed	Speed at which a motor outputs the highest possible power (rated power) under full load.
$M_0$ Stall torque	Thermal limit torque of the motor at standstill. The motor can deliver this torque for an unlimited length of time.
$I_0$ Stall current	Effective value of the motor phase current required to generate the stall torque.
$M_n$ Rated torque	Thermal limit torque of the motor at rated speed $n_N$ .
$I_N$ Rated current	R.m.s. value of the motor phase current required to generate the nominal torque.
$P_N$ Rated power	Continuous power output of the motor at the nominal operation point ( $M_N, n_N$ ) at rated current $I_N$ and rated voltage $U_N$ .
$M_{MAX}, I_{MAX}$ Limit characteristic	A maximum of four times the rated current may be applied to the motors.

Table: Definition: M-n characteristic for synchronous motors

### 3.12 Permissible axial and lateral forces of LST servomotors

Sizes	Radial force $F_{Rm}$ [N] at speed $n$ [rpm]					Axial force $F_{Am}$ [N] at speed $n$ [rpm]					$F_G$ [N]
	1000	2000	3000	4500	6000	1000	2000	3000	4500	6000	
LST-037	230	185	160	140	130	44	35	31	27	24	2
LST-050	325	260	225	195	175	62	50	43	37	34	2
LST-074	535	425	370	325	295	100	80	70	60	55	6
LST-097	920	730	640	560	510	175	140	120	105	95	18
LST-127	1000	790	690	600	550	190	150	130	115	105	34
LST-158	1020	810	710	620	560	195	155	135	120	110	60
LST-190	1950	1550	1350	1170	1070	370	290	260	225	200	100
LST-220	2500	1950	1700	1490	1350	470	370	320	280	260	200

Table: Permissible axial and lateral forces of LST servomotors.  $F_G$  ... Force due to weight of rotor.

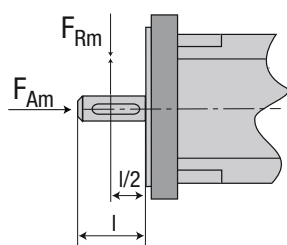

The table indicates the max. permissible lateral force  $F_{Rm}$  at the point of application  $l/2$  and the maximum permissible axial force  $F_{Am}$  for a service life of 20,000 h. A lateral force not applied in the middle of the shaft end can simply be translated to allow for the changed lever ratios.

Either the permissible radial force or the axial force may act on the motor shaft!

3

#### Technical data – design

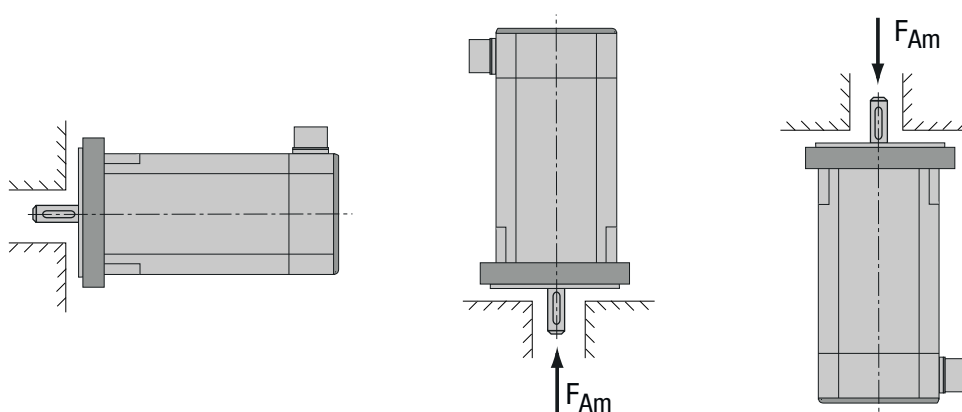

Design	B5	V1	V3
Shaft	Free shaft end	Free shaft end at bottom	Free shaft end at top
Attachment	Flange mounting Access from housing side	Flange mounting at bottom Access from housing side	Flange mounting at top Access from housing side



**NOTE:** With vertical mounting (V1) the permissible axial forces ( $F_A$ ) apply. With vertical upward mounting (V3) the permissible axial forces are reduced by the force due to weight of the rotor ( $F_G$ ).

### 3.13 Connections



LST-074-1-30-560/S4\*, G3\*  
 Plug alignment ————  
 Plug configuration ————

\*Example

Standard version

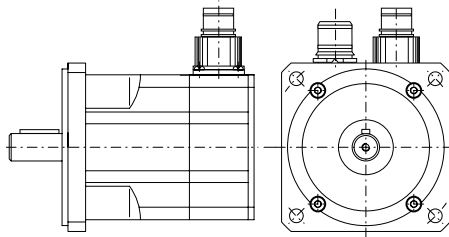

Straight plug

Version S4

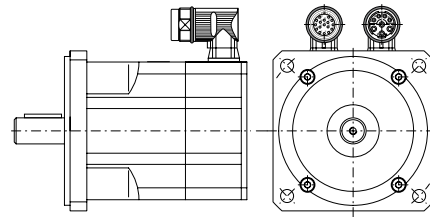

Angled/rotating plug

Version S7

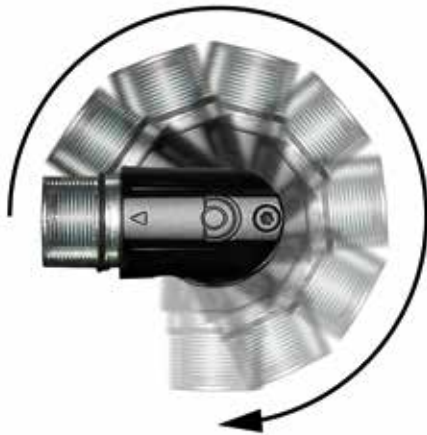

Angled plug rotating 270°

As from size LST-127, raised bodies are used for angled, rotating plugs with a rotation angle of 270°.



## Encoder connections

### Encoder connection xR (resolver)

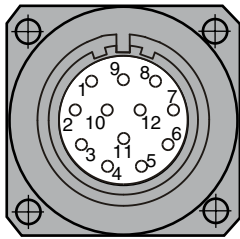

12-pin socket Junction box  
Contact pins Ø 1 mm

Pin	term	term
1	Cos +	(S1)
2	COS-	(S3)
3	SIN+	(S2)
4	SIN-	(S4)
6	REF+	(R1)
7	REF-	(R2)
11	PTC+	Motor PTC
12	PTC-	Motor PTC
5, 8, 9, 10	n. c.	Not used

Table: Encoder connection xR (resolver)

### Encoder connection Gx (optical encoder)

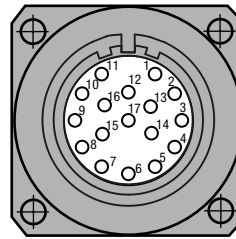

17-pin socket  
Junction box  
Contact pins Ø 1 mm

Pin	term G3, G5, G12.x	term G6.x
1	A+	A+
2	A-	A-
3	B+	B+
4	B -	B -
7	GND / 0V	GND / 0V
8	VCC +5 V/150 mA	-
9	-	VCC 7-12V/100mA
10	DATA+	DATA+
11	DATA-	DATA-
12	CLK+	-
13	CLK-	-
16	VCC-Sense	-
17	GND-Sense	-
5, 6, 14, 15	n. c.	n. c.

Table: Encoder connection Gx (optical encoder)

## Power connections

### Power connection

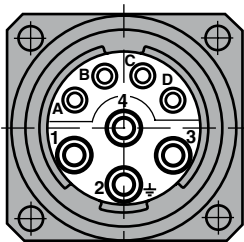

8-pin socket Junction box  
Contact pins  
for contact 1 ... 4 Ø 2 mm  
for contact A ... D Ø 1 mm

Pin	Des.	Designation
1	U	Motor phase U
2	PE	PE
3	W	Motor phase W
4	V	Motor phase V
A	Brake +	Brake+
B	Brake -	Brake -
C	PTC+	Motor PTC <sup>1)</sup>
D	PTC-	Motor PTC <sup>1)</sup>

<sup>1)</sup> For motors with resolver, not assigned

Table: Power connection of LST servomotors

### Power connection of LST 220

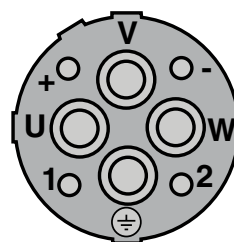

Pin	Des.	Designation
U	-	Motor phase U
V	-	Motor phase V
W	-	Motor phase W
PE	-	PE
1	PTC+	Motor PTC <sup>1)</sup>
2	PTC-	Motor PTC <sup>1)</sup>
+	Brake +	Brake+
-	Brake -	Brake -

<sup>1)</sup> For motors with resolver, not assigned

Table: Power connection of LST 220

## 3.14 Key definitions

---

**Stall torque  $M_0$  [Nm]**

The stall torque can be outputted for an unlimited time at speed  $n=0$  rpm and under nominal ambient conditions.

---

**Rated torque  $M_n$  [Nm]**

The rated torque is outputted when the motor is drawing rated current at rated speed. The rated torque can be outputted for an unlimited time at rated speed in continuous operation.

---

**Stall current  $I_0$  [A]**

The stall current is the sine-effective current value which the motor draws at standstill in order to output the stall torque.

---

**Rated current  $I_n$  [A]**

The rated current is the sine-effective current value which the motor draws at rated speed in order to output the rated torque.

---

**Maximum permissible current (peak current)  $I_{max}$  [A]**

The peak current (sine-effective value) should not be more than 4 times the rated current. The actual value is determined by the peak current of the inverter being used.

---

**Torque constant  $K_T$  [Nm/A]**

The torque constant indicates how much torque in Nm the motor generates with 1A sine-effective current. The equation is  $M=I \times K_T$

---

**Voltage constant  $K_E$  [V/1000 rpm]**

The voltage constant indicates the induced motor EMF as a sine peak value between two terminals, referred to 1000 rpm.

---

**Moment of inertia of rotor  $J$  [kgcm<sup>2</sup>]**

The constant  $J$  is a measure of the mass inertia of the motor.

---

**Thermal time constant  $T_{th}$  [min]**

The constant  $T_{th}$  indicates the warm-up time of the cold motor under  $I_0$  load until  $0.63 \times 105$  Kelvin overtemperature is reached. Under peak current the warm-up time is much shorter.

---

**Rated speed  $n_n$  [rpm]**

The rated speed is the speed at which a servomotor outputs the highest possible power – the so-called rated power –under full load.

---

Table: Key definitions

### 3.15 Overview of LST servomotors



#### Technical data

Motor type	Motor type/ Length	Stall torque $M_0$ [Nm]	Rated torque $M_N$ [Nm]	Rated current at 560 V $I_N$ [A]	Rated current at 320 V $I_N$ [A]	Rated speed $n_n$ [rpm]
LST-037	LST-037-1	0.10	0.09	-	0.56	6000
	LST-037-2	0.20	0.18	-	0.92	6000
	LST-037-3	0.30	0.27	-	0.89	6000
LST-050	LST-050-1	0.20	0.19	-	0.60	4500
	LST-050-2	0.40	0.36	-	0.88	4500
	LST-050-3	0.60	0.55	-	1.18	4500
	LST-050-4	0.80	0.72	-	1.47	4500
	LST-050-5	0.95	0.85	-	1.71	4500
LST-074	LST-074-1	0.65	0.60	0.64	1.04	3000
	LST-074-2	1.30	1.15	0.95	1.58	3000
	LST-074-3	1.90	1.60	1.26	2.20	3000
	LST-074-4	2.50	2.20	1.62	2.70	3000
	LST-074-5	3.00	2.50	1.82	3.00	3000
LST-097	LST-097-1	2.60	2.30	1.85	3.00	3000
	LST-097-2	3.90	3.30	2.60	4.30	3000
	LST-097-3	5.30	4.60	3.80	5.90	3000
	LST-097-4	7.50	6.40	4.40	8.10	3000
	LST-097-5	9.50	8.50	6.20	10.5	3000
LST-127	LST-127-1	6.60	5.70	4.00	-	3000
	LST-127-2	10.5	8.80	6.30	-	3000
	LST-127-3	13.5	11.0	9.50	-	3000
	LST-127-4	17.0	14.5	10.0	-	3000
	LST-127-5	22.0	17.0	13.0	-	3000
LST-158	LST-158-1	13.5	13.0	8.20	-	3000
	LST-158-2	19.0	17.0	10.6	-	3000
	LST-158-3	22.0	19.0	12.3	-	3000
	LST-158-4	29.0	24.0	14.7	-	3000
	LST-158-5	35.0	26.0	18.2	-	3000
LST-190	LST-190-1	27.0	21.0	13.5	-	3000
	LST-190-2	32.0	23.0	15.0	-	3000
	LST-190-3	40.0	26.0	17.9	-	3000
LST-220	LST-220-1	40.0	30.0	17.8	-	3000
	LST-220-2	68.0	50.0	31.1	-	3000
	LST-220-3	93.0	60.0	34.9	-	3000
	LST-220-4	115.0	50.0	29.3	-	3000

Table: Technical data of the LST servomotor series - all values with a tolerance of  $\pm 5\%$

3.16 Motor type:  
LST-037  
( $U_{dc} = 320 \text{ V}$ )



3.16.1 Dimensional sketch and technical data

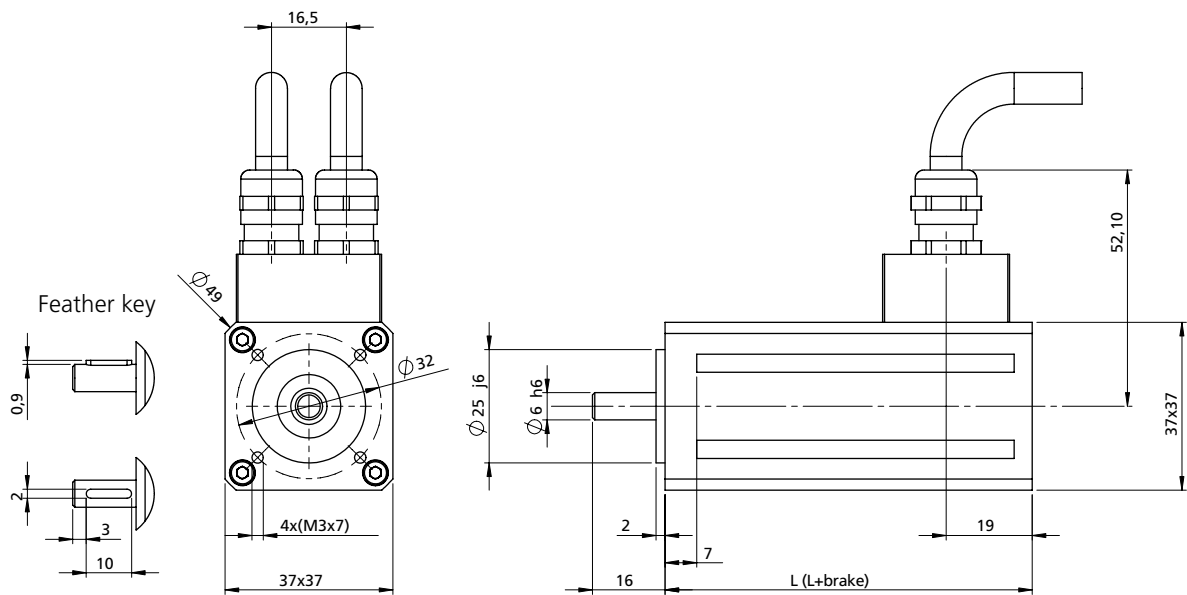

Motor type	L with resolver xR [mm]	L+brake with resolver xR [mm]	L with opt. encoder G12.xy [mm]	L with opt. encoder G6.xy [mm]
LST-037-1	81	111	Not available	Not available
LST-037-2	86	116	Not available	Not available
LST-037-3	111	141	Not available	Not available

Table: Overview of motor lengths

Technical data <sup>1)</sup>	Symbol	LST-037-1-60-320	LST-037-2-60-320	LST-037-3-60-320
Rated speed	$n_n$	6000 rpm	6000 rpm	6000 rpm
Rated frequency	$f_N$	300 Hz	300 Hz	300 Hz
DC link voltage (controller)	$U_{dc}$	320 V	320 V	320 V
Rated voltage	$U_n$	200 V	200 V	200 V
Rated torque	$M_n$	0.09 Nm	0.18 Nm	0.27 Nm
Rated current	$I_n$	0.56 A	0.92 A	0.89 A
Rated power	$P$	0.056 kW	0.11 kW	0.17 kW
Stall torque	$M_0$	0.10 Nm	0.20 Nm	0.30 Nm
Stall current	$I_0$	0.58 A	0.97 A	0.95 A
Maximum permissible torque	$M_{max}$	0.40 Nm	0.80 Nm	1.20 Nm
Maximum permissible current	$I_{max}$	2.5 A	4.2 A	4.1 A
Maximum permissible speed	$n_{max}$	12000 rpm	12000 rpm	12000 rpm
Voltage constant	$K_E$	10.5 V/1000 rpm	12.5 V/1000 rpm	19.0 V/1000 rpm
Torque constant	$K_T$	0.17 Nm/A	0.21 Nm/A	0.31 Nm/A
Winding resistance (2 phases)	$R_{2ph}$	38.9 $\Omega$	18.9 $\Omega$	22.9 $\Omega$
Winding inductance (2 phases)	$L_{2ph}$	6.5 mH	4.5 mH	6.5 mH
No load speed	$n_0$	19050 rpm	16000 rpm	10460 rpm
Electrical time constant	$T_{el}$	0.17 ms	0.24 ms	0.28 ms
Thermal time constant	$T_{th}$	18 min.	20 min.	20 min.
Moment of inertia of the motor	$J$	0.000006 kgm <sup>2</sup>	0.000008 kgm <sup>2</sup>	0.000008 kgm <sup>2</sup>
Mass	$m$	0.37 kg	0.45 kg	0.45 kg

#### Brake (optional)

Rated voltage	$U_N$	24 V $\pm$ 10 %
Rated current at 20 °C for venting	$I_N$	0.33 A
Permissible maximum speed	$n_{max}$	10000 rpm
Permissible friction energy	$W_R$	0.20 x 10 <sup>6</sup> Ws
Mass moment of inertia	$J_B$	0.0000013 kgm <sup>2</sup>
Mass	$m$	0.075 kg
Braking torque	$M_H$	0.4 Nm

<sup>1)</sup> All values with a tolerance of  $\pm$  10%.

### 3.16.2 Characteristics

Explanations of characteristics:

The characteristic  $M_{max}$  describes the maximum possible short-time torque at corresponding speed. It is important for dynamic processes.

The characteristic  $M_n$  indicates the thermally permissible rated torque.

The characteristics are limited by the respective maximum permissible speed  $n_{max}$  (for  $n_{max}$  refer to the "Technical data" table).

3

#### LST-037-1-60-320

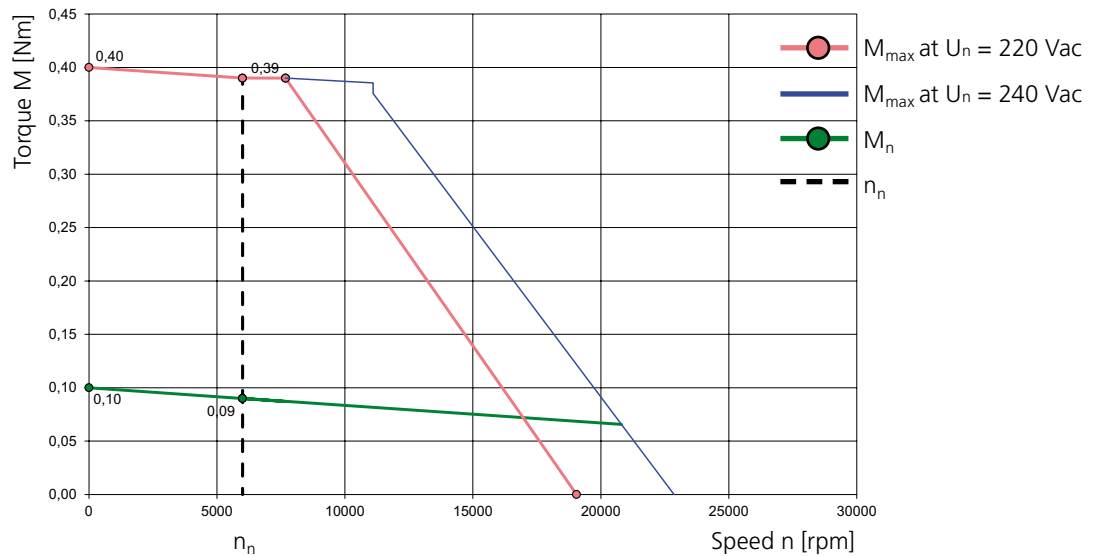

#### LST-037-2-60-320

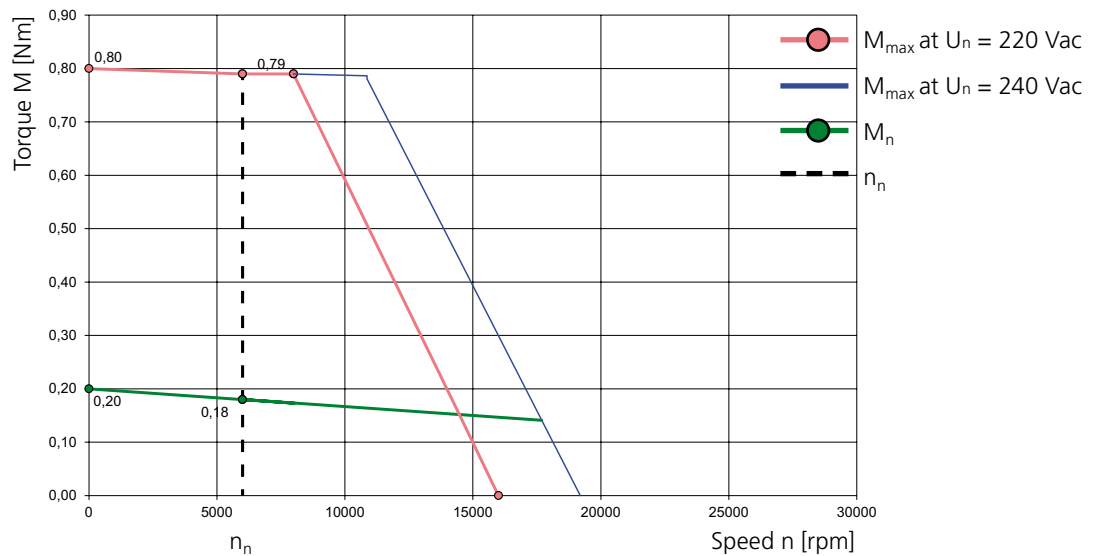

# LST-037-3-60-320

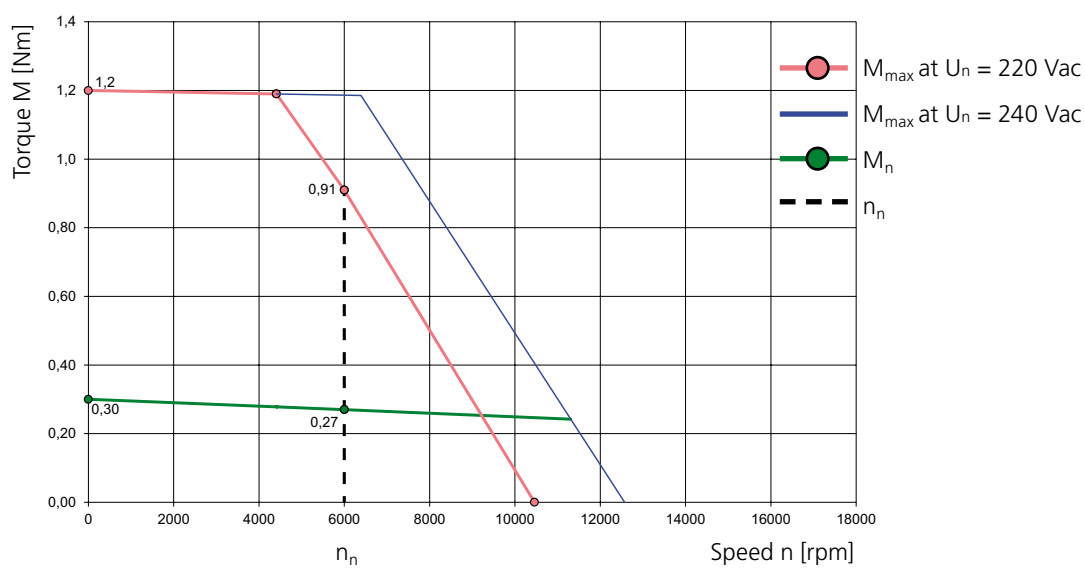

### 3.17 Motor type: LST-050 ( $U_{dc} = 320\text{ V}$ )



#### 3.17.1 Dimensional sketch and technical data

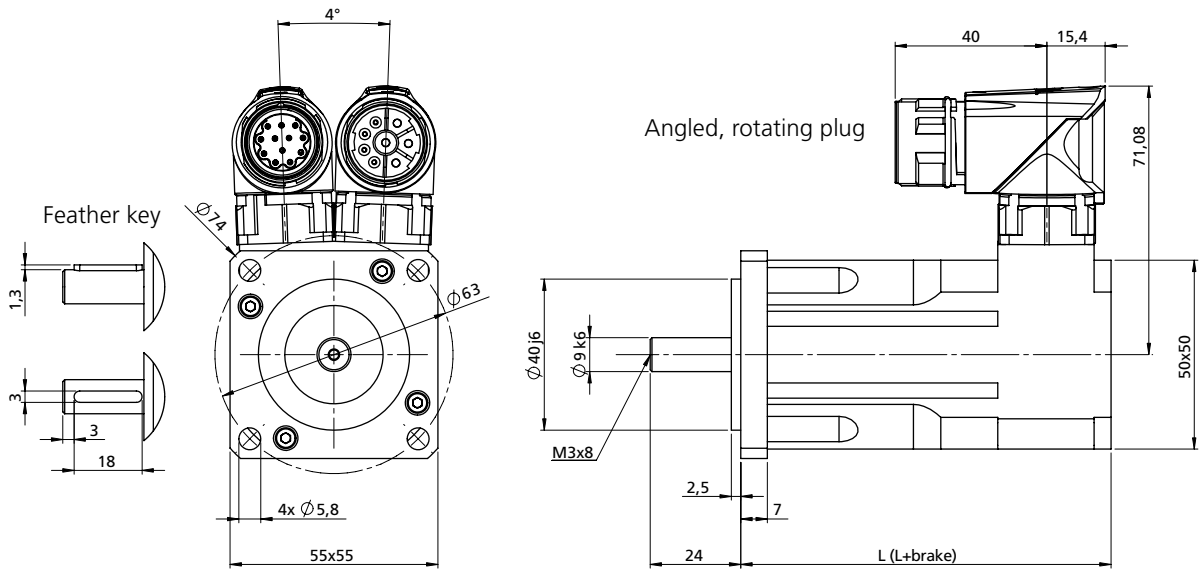

Motor type	L with resolver xR [mm]	L+brake with resolver xR [mm]	L with opt. encoder G12.xy [mm]	L+brake with opt. encoder G12.xy [mm]	L with opt. encoder G6.1x [mm]	L+brake with opt. encoder G6.1x [mm]
LST-050-1	98	131	141.5	174.5	In preparation	In preparation
LST-050-2	113	146	156.5	189.5	In preparation	In preparation
LST-050-3	128	161	171.5	204.5	In preparation	In preparation
LST-050-4	143	176	186.5	219.5	In preparation	In preparation
LST-050-5	158	191	201.5	234.5	In preparation	In preparation

Motor type	L with opt. encoder G6.2x [mm]	L+brake with opt. encoder G6.2x [mm]	L with opt. encoder G6.3x [mm]	L+brake with opt. encoder G6.3x [mm]	L with opt. encoder G3/G5 [mm]	L+brake with opt. encoder G3/G5 [mm]
LST-050-1	109	142	98	131	In preparation	In preparation
LST-050-2	124	157	113	146	In preparation	In preparation
LST-050-3	139	172	128	161	In preparation	In preparation
LST-050-4	154	187	143	176	In preparation	In preparation
LST-050-5	169	202	158	191	In preparation	In preparation

Table: Overview of motor lengths – for overview of encoder types see section 5.1



Technical data <sup>1)</sup>	Symbol	LST-050-1-45-320	LST-050-2-45-320	LST-050-3-45-320	LST-050-4-45-320	LST-050-5-45-320
Rated speed	$n_n$	4500 rpm	4500 rpm	4500 rpm	4500 rpm	4500 rpm
Rated frequency	$f_N$	225 Hz	225 Hz	225 Hz	225 Hz	225 Hz
DC link voltage (controller)	$U_{dc}$	320 V	320 V	320 V	320 V	320 V
Rated voltage	$U_n$	200 V	200 V	200 V	200 V	200 V
Rated torque	$M_n$	0.19 Nm	0.36 Nm	0.55 Nm	0.72 Nm	0.85 Nm
Rated current	$I_n$	0.60 A	0.88 A	1.18 A	1.47 A	1.71 A
Rated power	$P$	0.089 kW	0.17 kW	0.26 kW	0.34 kW	0.44 kW
Stall torque	$M_0$	0.20 Nm	0.40 Nm	0.60 Nm	0.80 Nm	0.95 Nm
Stall current	$I_0$	0.59 A	0.93 A	1.23 A	1.56 A	1.82 A
Maximum permissible torque	$M_{max}$	0.80 Nm	1.6 Nm	2.4 Nm	3.2 Nm	3.8 Nm
Maximum permissible current	$I_{max}$	2.5 A	4.0 A	5.3 A	6.7 A	7.8 A
Maximum permissible speed	$n_{max}$	12000 rpm	12000 rpm	12000 rpm	12000 rpm	12000 rpm
Voltage constant	$K_E$	20.5 V/ 1000 rpm	26.0 V/ 1000 rpm	29.5 V/ 1000 rpm	31.0 V/ 1000 rpm	31.5 V/ 1000 rpm
Torque constant	$K_T$	0.34 Nm/A	0.43 Nm/A	0.49 Nm/A	0.51 Nm/A	0.52 Nm/A
Winding resistance (2 phases)	$R_{2ph}$	54 $\Omega$	26.3 $\Omega$	19.9 $\Omega$	14.6 $\Omega$	10.7 $\Omega$
Winding inductance (2 phases)	$L_{2ph}$	32 mH	21.4 mH	17.2 mH	14.4 mH	11.3 mH
No load speed	$n_0$	9760 rpm	7690 rpm	6780 rpm	6450 rpm	6350 rpm
Electrical time constant	$T_{el}$	0.59 ms	0.82 ms	0.87 ms	0.98 ms	1.1 ms
Thermal time constant	$T_{th}$	10 min.	15 min.	20 min.	22 min.	27 min.
Moment of inertia of the motor	$J$	0.000006 kgm <sup>2</sup>	0.000008 kgm <sup>2</sup>	0.000011 kgm <sup>2</sup>	0.000013 kgm <sup>2</sup>	0.000018 kgm <sup>2</sup>
Mass	$m$	0.90 kg	1.06 kg	1.21 kg	1.36 kg	1.52 kg

#### Brake (optional)

Rated voltage	$U_N$	24 V $\pm$ 10 %
Rated current at 20 °C for venting	$I_N$	0.46 A
Permissible maximum speed	$n_{max}$	10000 rpm
Permissible friction energy	$W_R$	0.41 x 10 <sup>6</sup> Ws
Mass moment of inertia	$J_B$	0.000007 kgm <sup>2</sup>
Mass	$m$	0.15 kg
Braking torque	$M_H$	2.0 Nm

1) All values with a tolerance of  $\pm$  10%.

### 3.17.2 Characteristics

Explanations of characteristics:

The characteristic  $M_{max}$  describes the maximum possible short-time torque at corresponding speed. It is important for dynamic processes.

The characteristic  $M_n$  indicates the thermally permissible rated torque.

The characteristics are limited by the respective maximum permissible speed  $n_{max}$  (for  $n_{max}$  refer to the "Technical data" table).

3

#### LST-050-1-45-320

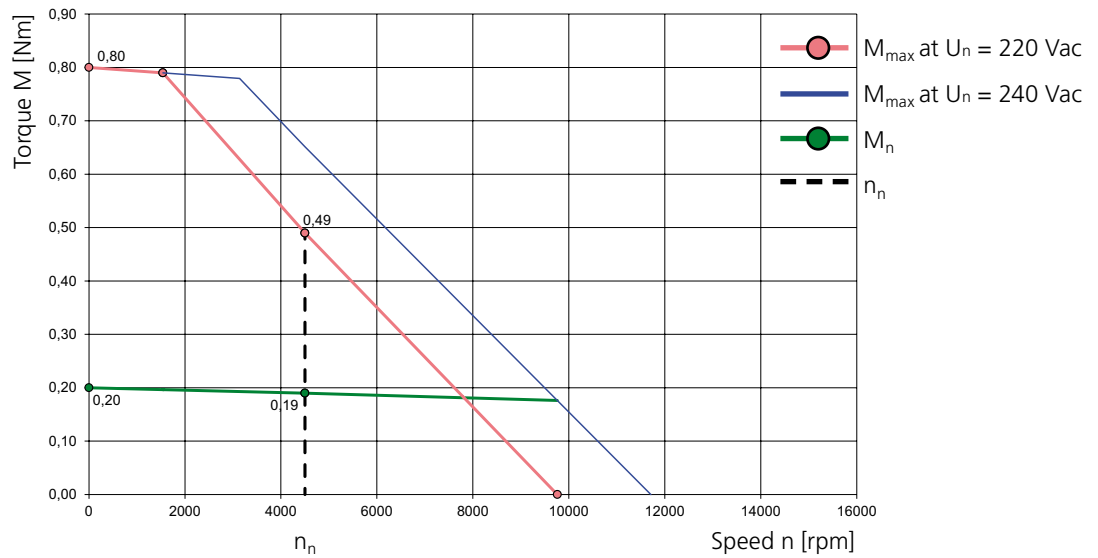

#### LST-050-2-45-320

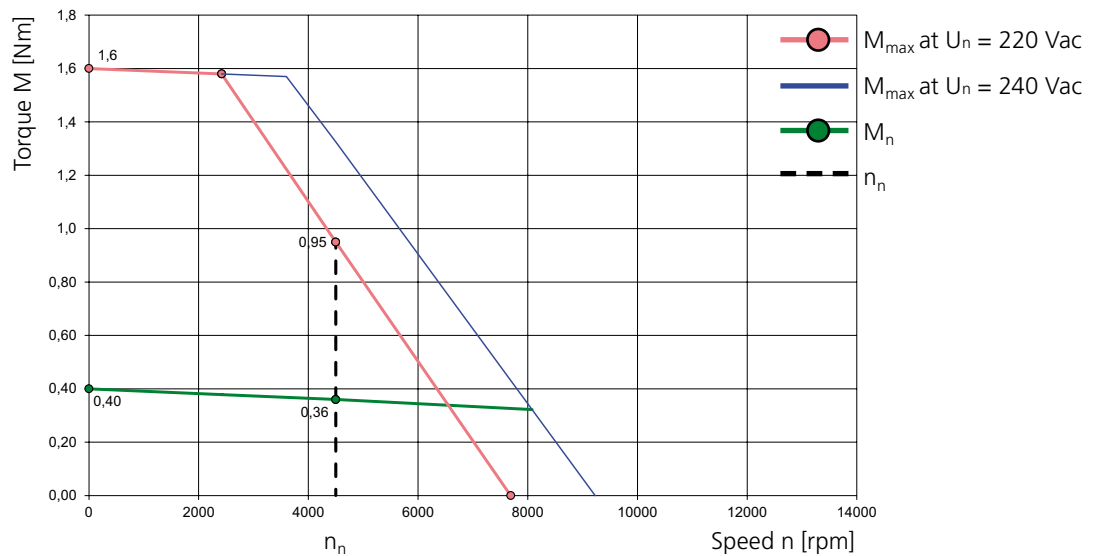

### LST-050-3-45-320

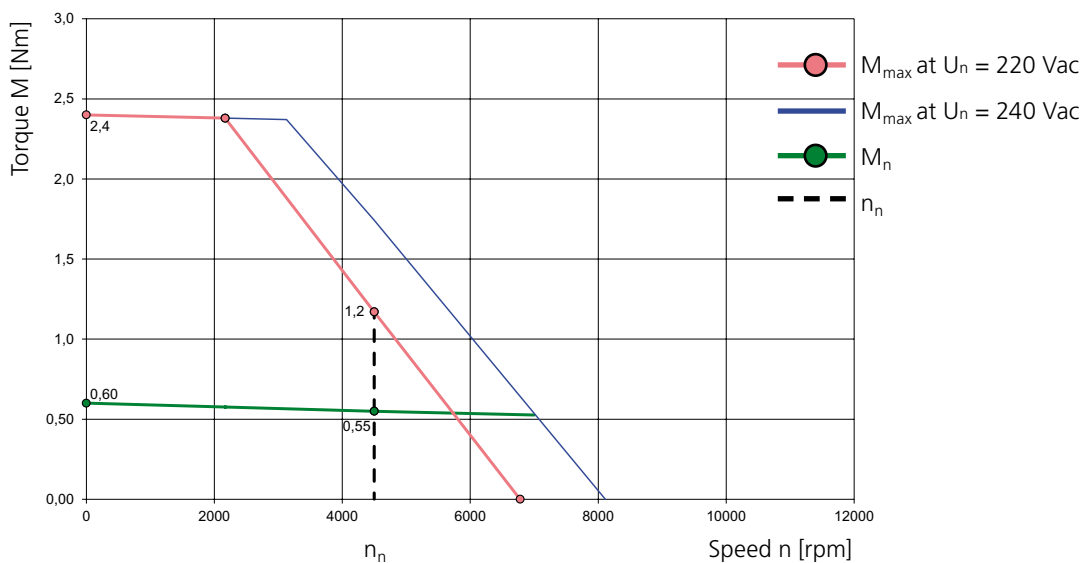

### LST-050-4-45-320

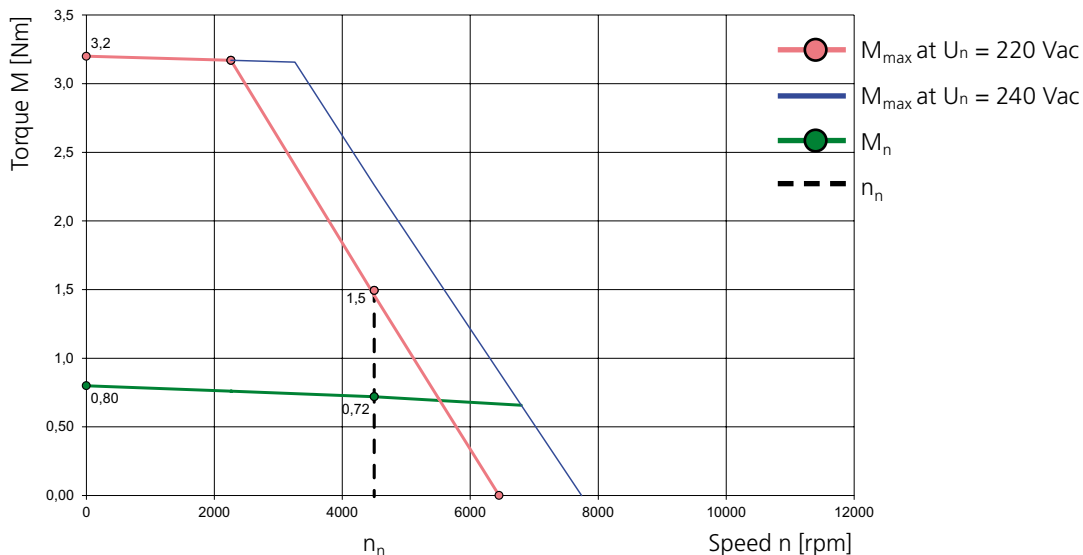

### LST-050-5-45-320

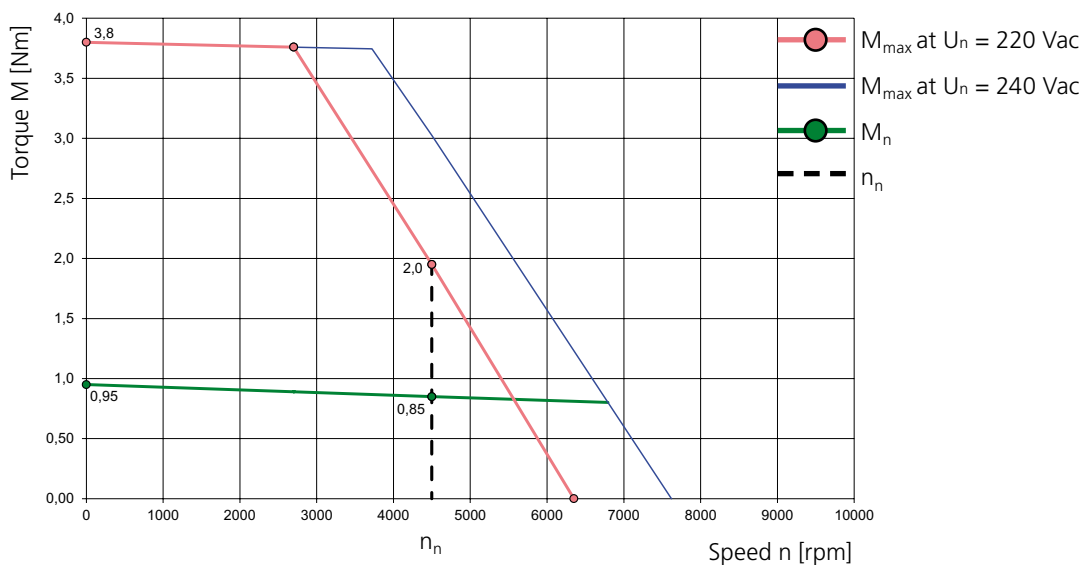

### 3.18 Motor type: LST-074 ( $U_{dc} = 320\text{ V}$ )



#### 3.18.1 Dimensional sketch and technical data

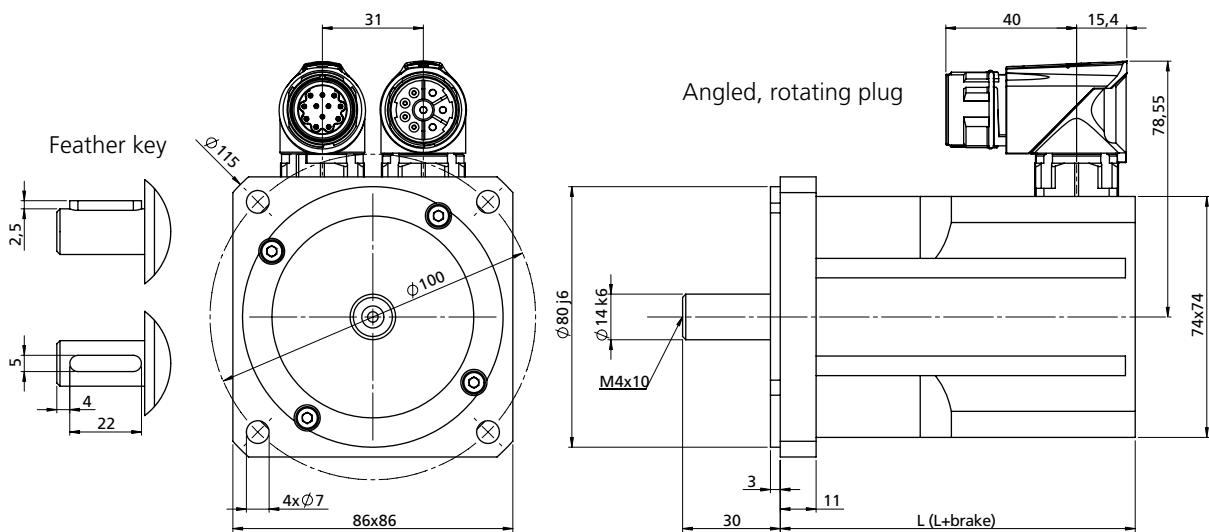

Motor type	L with resolver xR [mm]	L+brake with resolver xR [mm]	L with opt. encoder G12.xy [mm]	L+brake with opt. encoder G12.xy [mm]	L with opt. encoder G6.1x [mm]	L+brake with opt. encoder G6.1x [mm]
LST-074-1	109	142	150	183	128.5	161.5
LST-074-2	127	160	168	201	146.5	179.5
LST-074-3	145	178	186	219	164.5	197.5
LST-074-4	163	196	204	237	182.5	215.5
LST-074-5	181	214	222	255	200.5	233.5

Motor type	L with opt. encoder G6.2x [mm]	L+brake with opt. encoder G6.2x [mm]	L with opt. encoder G6.3x [mm]	L+brake with opt. encoder G6.3x [mm]	L with opt. encoder G3/G5 [mm]	L+brake with opt. encoder G3/G5 [mm]
LST-074-1	126	159	109	142	139	172
LST-074-2	144	177	127	160	157	190
LST-074-3	162	195	145	178	175	208
LST-074-4	180	213	163	196	193	226
LST-074-5	198	231	181	214	211	244

Table: Overview of motor lengths – for overview of encoder types see section 5.1

Technical data <sup>1)</sup>	Symbol	LST-074-1-30-320	LST-074-2-30-320	LST-074-3-30-320	LST-074-4-30-320	LST-074-5-30-320
Rated speed	$n_n$	3000 rpm	3000 rpm	3000 rpm	3000 rpm	3000 rpm
Rated frequency	$f_N$	150 Hz	150 Hz	150 Hz	150 Hz	150 Hz
DC link voltage (controller)	$U_{dc}$	320 V	320 V	320 V	320 V	320 V
Rated voltage	$U_n$	200 V	200 V	200 V	200 V	200 V
Rated torque	$M_n$	0.60 Nm	1.15 Nm	1.6 Nm	2.2 Nm	2.5 Nm
Rated current	$I_n$	1.04 A	1.58 A	2.2 A	2.7 A	3.0 A
Rated power	$P$	0.18 kW	0.36 kW	0.5 kW	0.69 kW	0.78 kW
Stall torque	$M_0$	0.65 Nm	1.3 Nm	1.9 Nm	2.5 Nm	3.0 Nm
Stall current	$I_0$	1.06 A	1.67 A	2.5 A	3.0 A	3.5 A
Maximum permissible torque	$M_{max}$	2.6 Nm	5.2 Nm	7.6 Nm	10.0 Nm	12.0 Nm
Maximum permissible current	$I_{max}$	4.6 A	7.2 A	10.7 A	13.0 A	15.0 A
Maximum permissible speed	$n_{max}$	12000 rpm	12000 rpm	12000 rpm	12000 rpm	12000 rpm
Voltage constant	$K_E$	37.0 V/ 1000 rpm	47.0 V/ 1000 rpm	46.0 V/ 1000 rpm	50.0 V/ 1000 rpm	52.0 V/ 1000 rpm
Torque constant	$K_T$	0.61 Nm/A	0.78 Nm/A	0.76 Nm/A	0.83 Nm/A	0.86 Nm/A
Winding resistance (2 phases)	$R_{2ph}$	28.2 $\Omega$	12.7 $\Omega$	6.7 $\Omega$	5.4 $\Omega$	4.1 $\Omega$
Winding inductance (2 phases)	$L_{2ph}$	33.3 mH	21.5 mH	13.1 mH	11.7 mH	9.4 mH
No load speed	$n_0$	5410 rpm	4260 rpm	4350 rpm	4000 rpm	3850 rpm
Electrical time constant	$T_{el}$	1.2 ms	1.7 ms	2.0 ms	2.2 ms	2.3 ms
Thermal time constant	$T_{th}$	25 min.	30 min.	31 min.	32 min.	33 min.
Moment of inertia of the motor	$J$	0.00005 kgm <sup>2</sup>	0.000065 kgm <sup>2</sup>	0.000092 kgm <sup>2</sup>	0.00014 kgm <sup>2</sup>	0.00015 kgm <sup>2</sup>
Mass	$m$	1.75 kg	2.25 kg	2.7 kg	3.2 kg	3.65 kg

#### Brake (optional)

Rated voltage	$U_N$	24 V $\pm$ 10 %
Rated current at 20 °C for venting	$I_N$	0.5 A
Permissible maximum speed	$n_{max}$	10000 rpm
Permissible friction energy	$W_R$	0.58 x 10 <sup>6</sup> Ws
Mass moment of inertia	$J_B$	0.000018 kgm <sup>2</sup>
Mass	$m$	0.3 kg
Braking torque	$M_H$	4.5 Nm

1) All values with a tolerance of  $\pm$  10%.

### 3.18.2 Characteristics

Explanations of characteristics:

The characteristic  $M_{max}$  describes the maximum possible short-time torque at corresponding speed. It is important for dynamic processes.

The characteristic  $M_n$  indicates the thermally permissible rated torque.

The characteristics are limited by the respective maximum permissible speed  $n_{max}$  (for  $n_{max}$  refer to the "Technical data" table).

3

#### LST-074-1-30-320

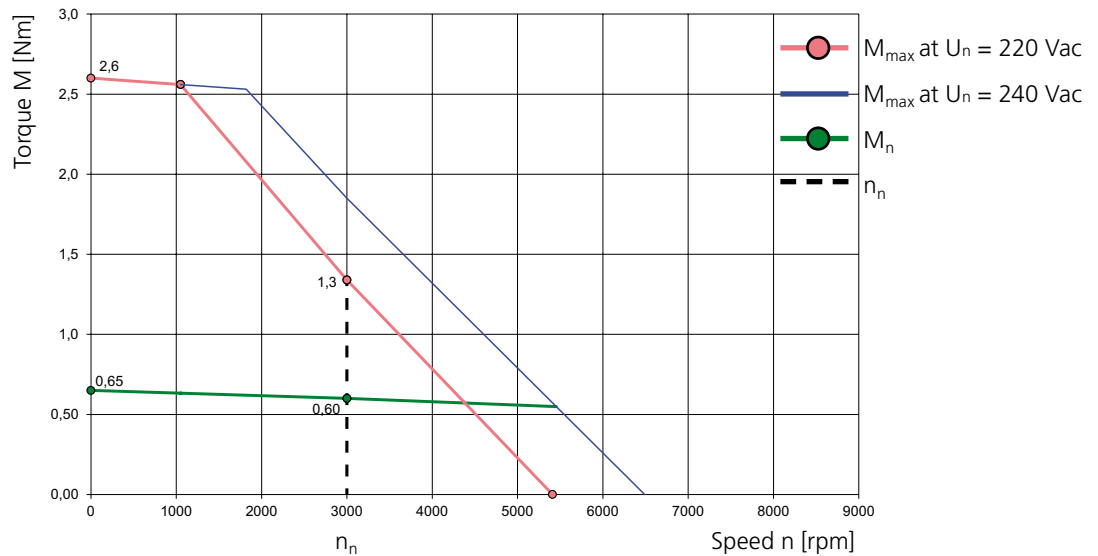

#### LST-074-2-30-320

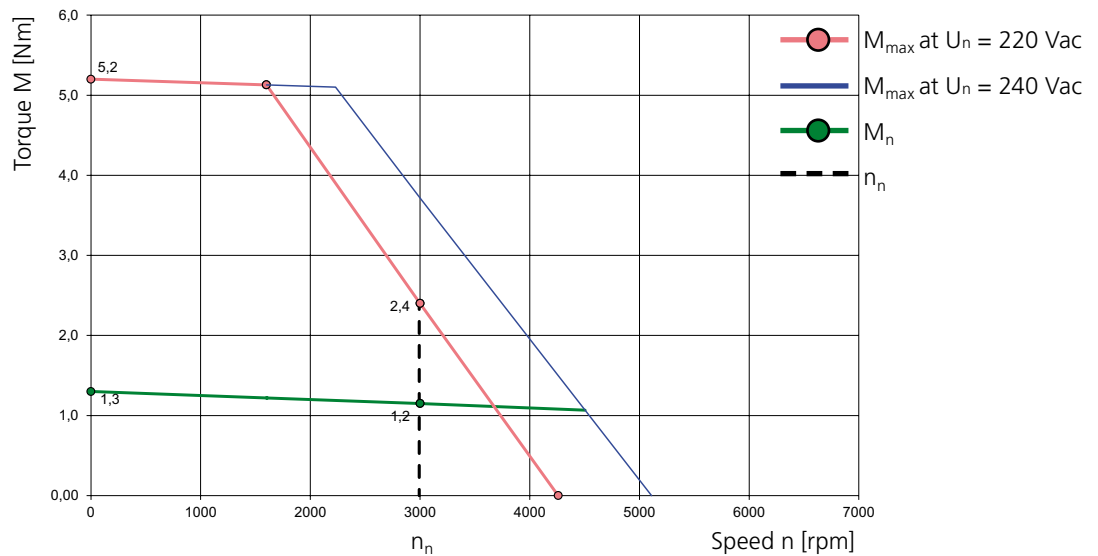

### LST-074-3-30-320

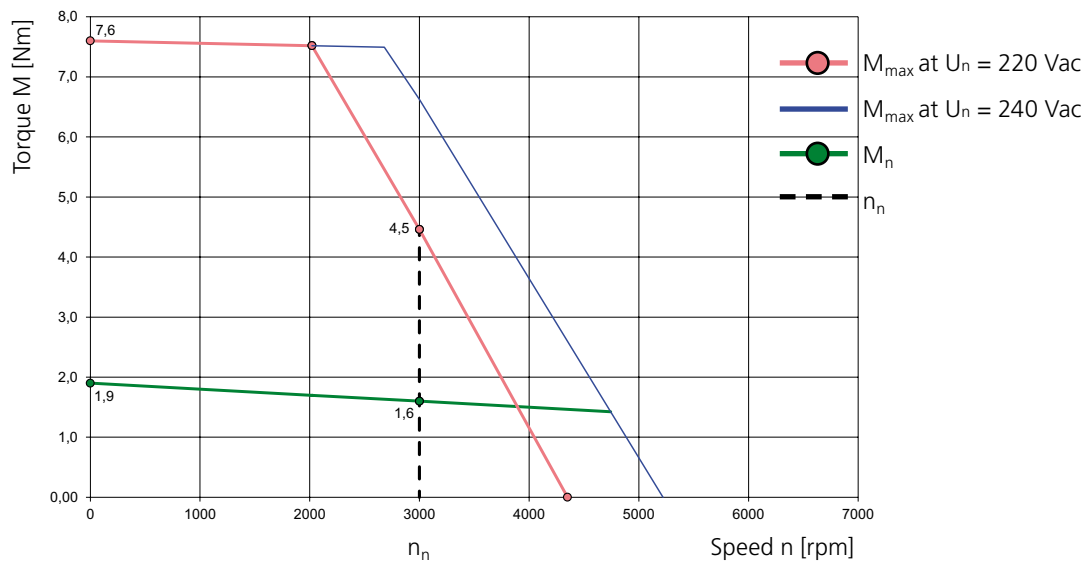

### LST-074-4-30-320

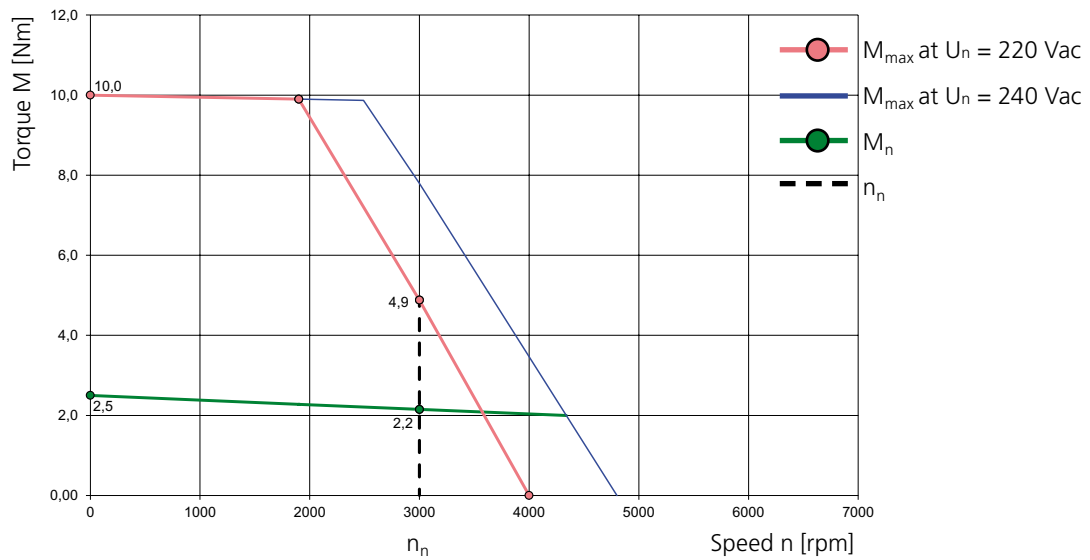

### LST-074-5-30-320

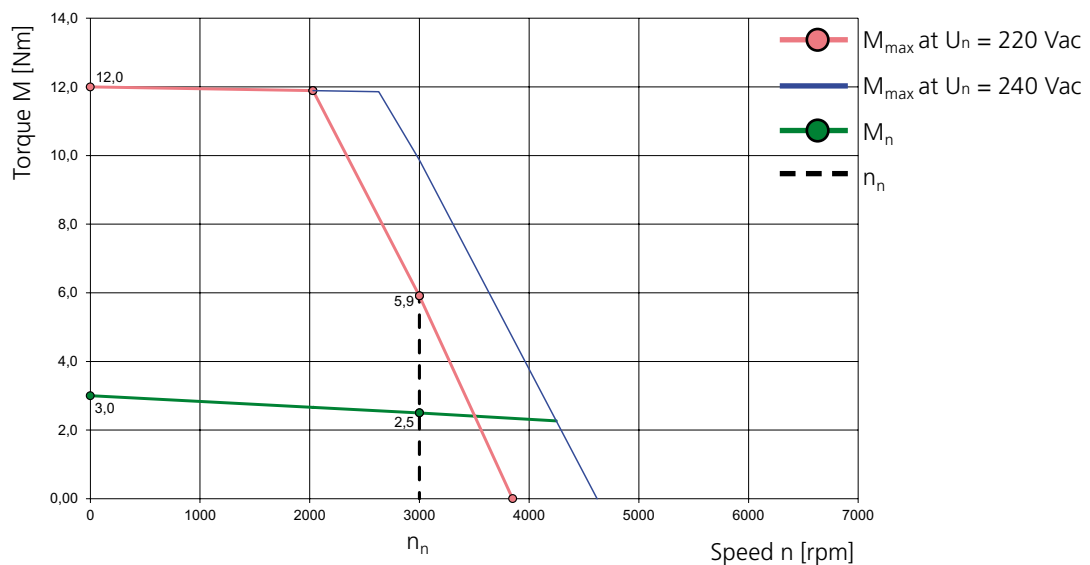

### 3.19 Motor type: LST-074 ( $U_{dc} = 560 \text{ V}$ )



#### 3.19.1 Dimensional sketch and technical data

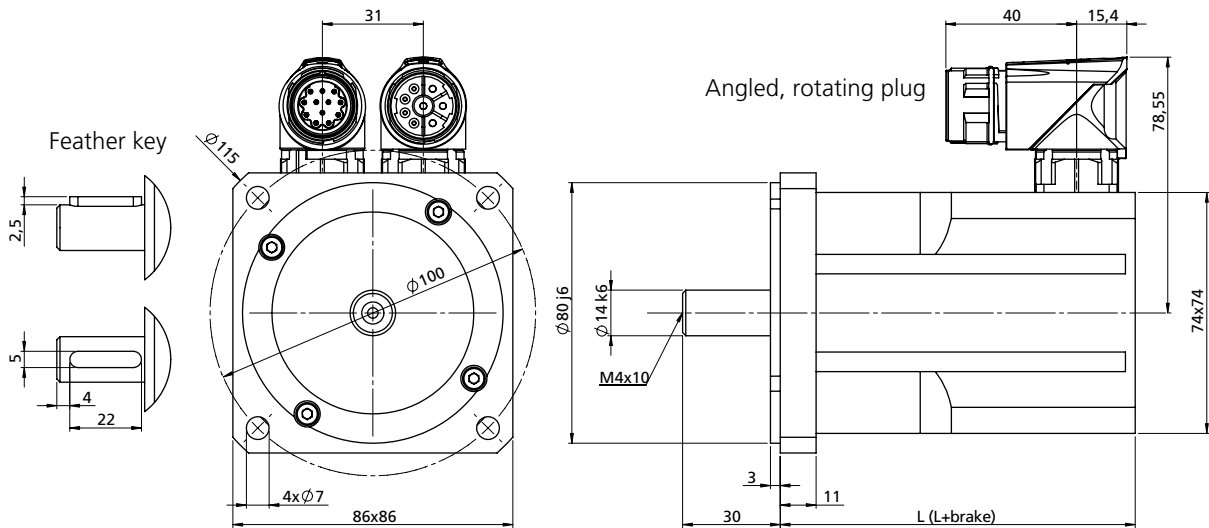

Motor type	L with resolver xR [mm]	L+brake with resolver xR [mm]	L with opt. encoder G12.xy [mm]	L+brake with opt. encoder G12.xy [mm]	L with opt. encoder G6.1x [mm]	L+brake with opt. encoder G6.1x [mm]
LST-074-1	109	142	150	183	128.5	161.5
LST-074-2	127	160	168	201	146.5	179.5
LST-074-3	145	178	186	219	164.5	197.5
LST-074-4	163	196	204	237	182.5	215.5
LST-074-5	181	214	222	255	200.5	233.5

Motor type	L with opt. encoder G6.2x [mm]	L+brake with opt. encoder G6.2x [mm]	L with opt. encoder G6.3x [mm]	L+brake with opt. encoder G6.3x [mm]	L with opt. encoder G3/G5 [mm]	L+brake with opt. encoder G3/G5 [mm]
LST-074-1	126	159	109	142	139	172
LST-074-2	144	177	127	160	157	190
LST-074-3	162	195	145	178	175	208
LST-074-4	180	213	163	196	193	226
LST-074-5	198	231	181	214	211	244

Table: Overview of motor lengths – for overview of encoder types see section 5.1



Technical data <sup>1)</sup>	Symbol	LST-074-1-30-560	LST-074-2-30-560	LST-074-3-30-560	LST-074-4-30-560	LST-074-5-30-560
Rated speed	$n_n$	3000 rpm	3000 rpm	3000 rpm	3000 rpm	3000 rpm
Rated frequency	$f_N$	150 Hz	150 Hz	150 Hz	150 Hz	150 Hz
DC link voltage (controller)	$U_{dc}$	560 V	560 V	560 V	560 V	560 V
Rated voltage	$U_n$	330 V	330 V	330 V	330 V	330 V
Rated torque	$M_n$	0.60 Nm	1.15 Nm	1.6 Nm	2.2 Nm	2.5 Nm
Rated current	$I_n$	0.64 A	0.95 A	1.26 A	1.62 A	1.82 A
Rated power	$P$	0.18 kW	0.36 kW	0.5 kW	0.69 kW	0.78 kW
Stall torque	$M_0$	0.65 Nm	1.3 Nm	1.9 Nm	2.5 Nm	3.0 Nm
Stall current	$I_0$	0.65 A	1.01 A	1.42 A	1.8 A	2.1 A
Maximum permissible torque	$M_{max}$	2.6 Nm	5.2 Nm	7.6 Nm	10.0 Nm	12.0 Nm
Maximum permissible current	$I_{max}$	2.8 A	4.3 A	6.1 A	7.7 A	9.0 A
Maximum permissible speed	$n_{max}$	12000 rpm	12000 rpm	12000 rpm	12000 rpm	12000 rpm
Voltage constant	$K_E$	60.0 V/ 1000 rpm	46.0 V/ 1000 rpm	81.0 V/ 1000 rpm	84.0 V/ 1000 rpm	87.0 V/ 1000 rpm
Torque constant	$K_T$	0.99 Nm/A	0.78 Nm/A	1.34 Nm/A	1.39 Nm/A	1.44 Nm/A
Winding resistance (2 phases)	$R_{2ph}$	75 $\Omega$	34.5 $\Omega$	20.9 $\Omega$	15.0 $\Omega$	11.6 $\Omega$
Winding inductance (2 phases)	$L_{2ph}$	88 mH	62 mH	40.4 mH	33.2 mH	26.7 mH
No load speed	$n_0$	5500 rpm	4230 rpm	4070 rpm	3930 rpm	3790 rpm
Electrical time constant	$T_{el}$	1.2 ms	1.8 ms	1.9 ms	2.2 ms	2.3 ms
Thermal time constant	$T_{th}$	25 min.	30 min.	31 min.	32 min.	33 min.
Moment of inertia of the motor	$J$	0.00005 kgm <sup>2</sup>	0.000065 kgm <sup>2</sup>	0.000092 kgm <sup>2</sup>	0.00014 kgm <sup>2</sup>	0.00015 kgm <sup>2</sup>
Mass	$m$	1.75 kg	2.25 kg	2.7 kg	3.2 kg	3.65 kg

#### Brake (optional)

Rated voltage	$U_N$	24 V $\pm$ 10 %
Rated current at 20 °C for venting	$I_N$	0.5 A
Permissible maximum speed	$n_{max}$	10000 rpm
Permissible friction energy	$W_R$	0.58 x 10 <sup>6</sup> Ws
Mass moment of inertia	$J_B$	0.000018 kgm <sup>2</sup>
Mass	$m$	0.3 kg
Braking torque	$M_H$	4.5 Nm

1) All values with a tolerance of  $\pm$  10%.

### 3.19.2 Characteristics

Explanations of characteristics:

The characteristic  $M_{max}$  describes the maximum possible short-time torque at corresponding speed. It is important for dynamic processes.

The characteristic  $M_n$  indicates the thermally permissible rated torque.

The characteristics are limited by the respective maximum permissible speed  $n_{max}$  (for  $n_{max}$  refer to the "Technical data" table).

3

#### LST-074-1-30-560

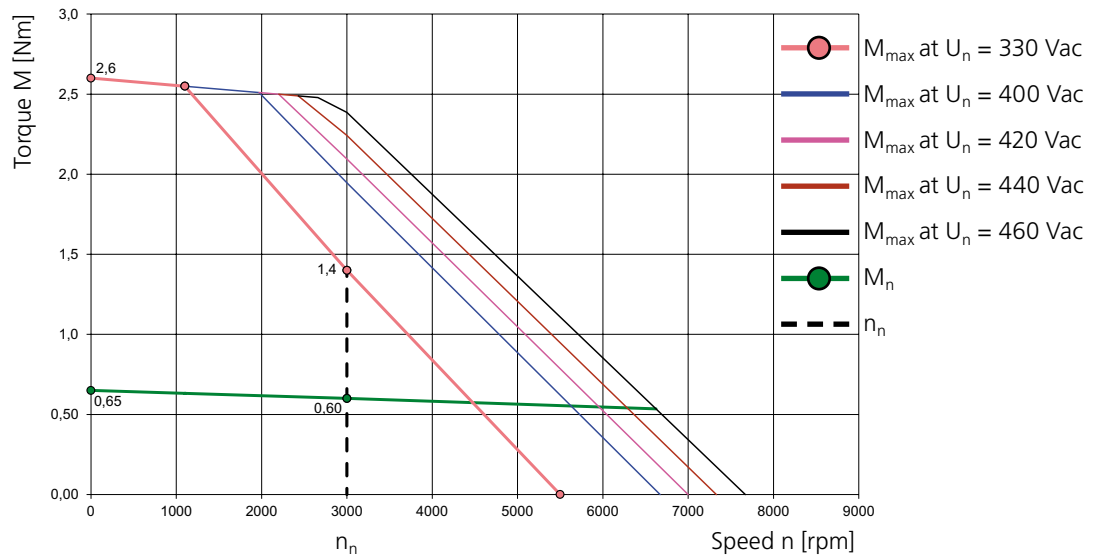

#### LST-074-2-30-560

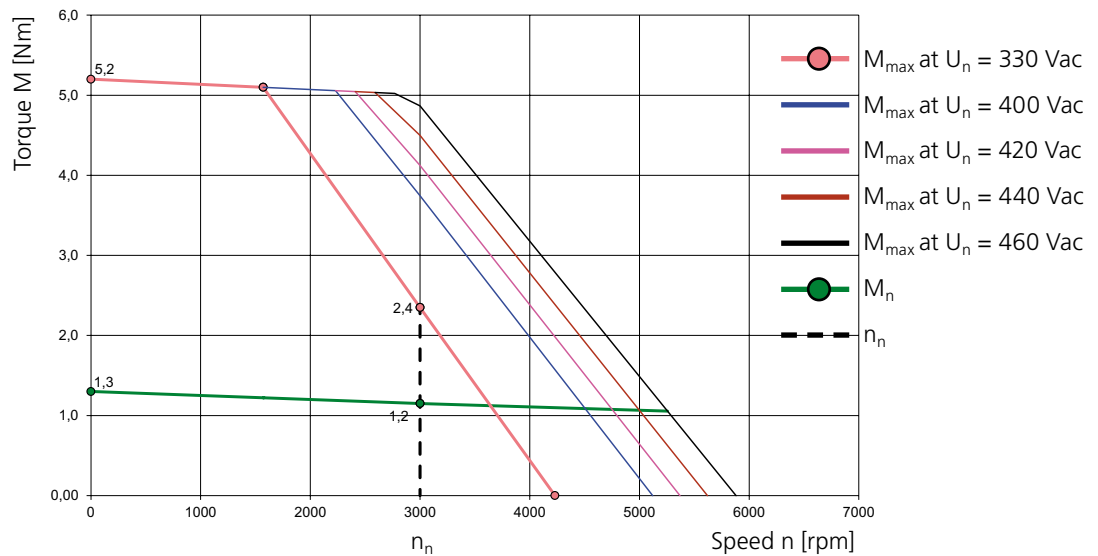

### LST-074-3-30-560

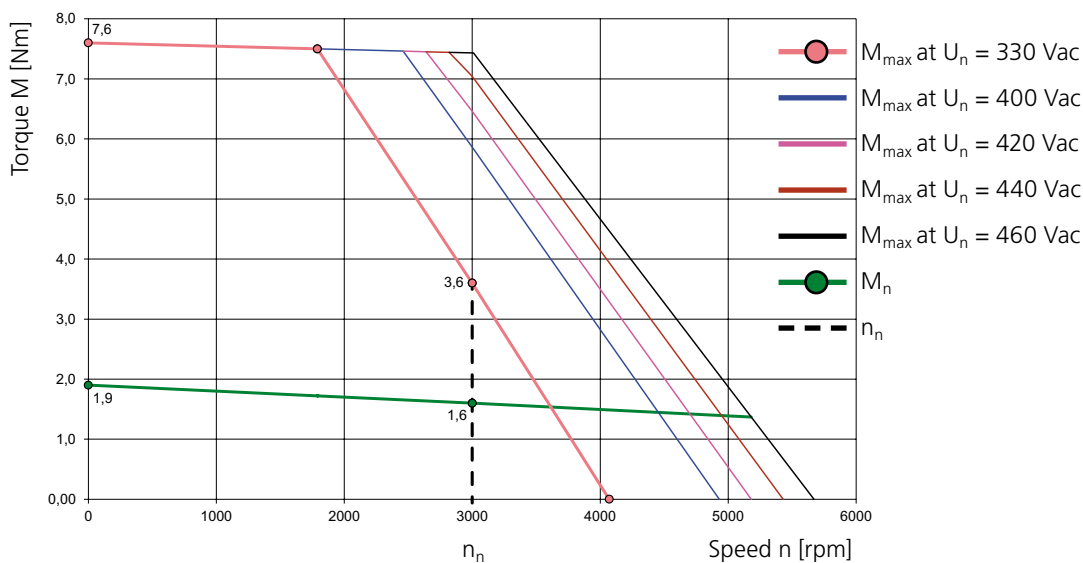

### LST-074-4-30-560

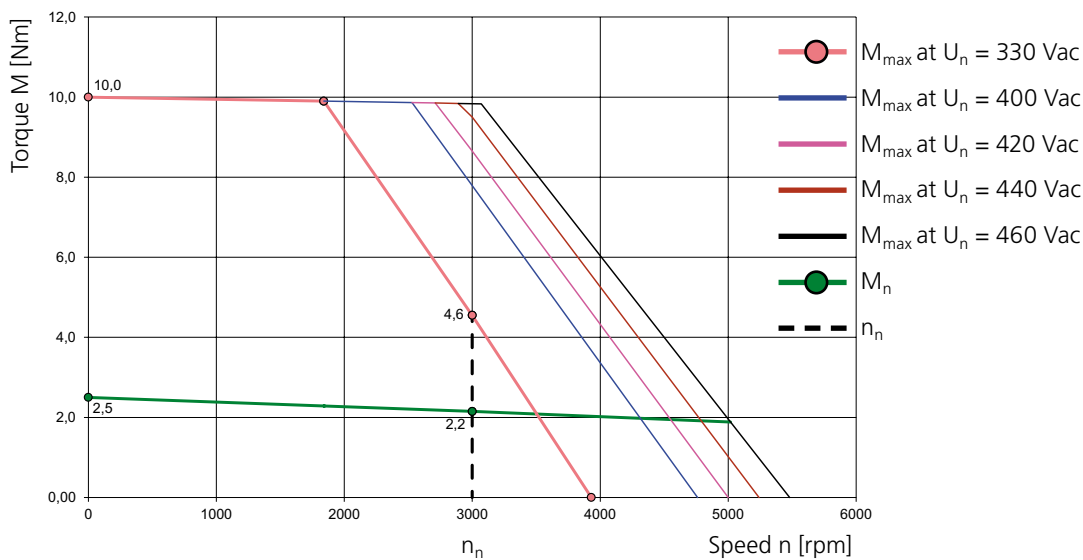

### LST-074-5-30-560

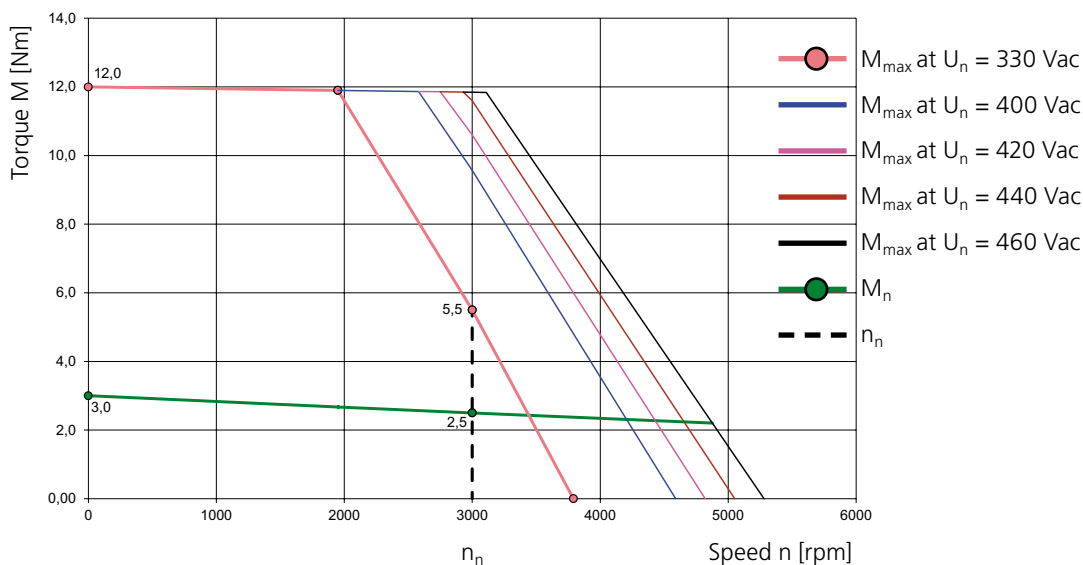

### 3.20 Motor type: LST-097 ( $U_{dc} = 320\text{ V}$ )



#### 3.20.1 Dimensional sketch and technical data

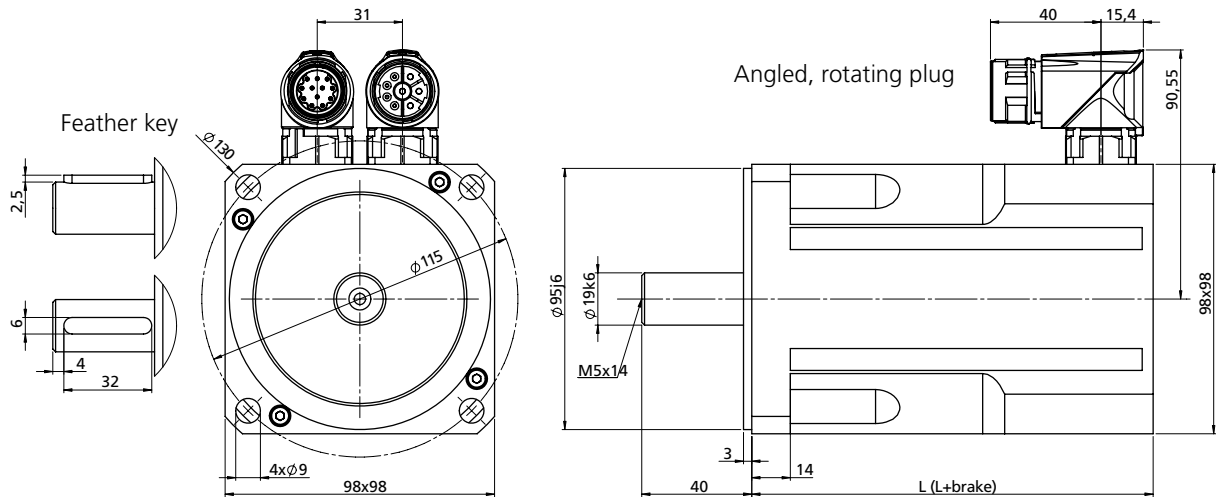

Motor type	L with resolver xR [mm]	L+brake with resolver xR [mm]	L with opt. encoder G12.xy [mm]	L+brake with opt. encoder G12.xy [mm]	L with opt. encoder G6.1x [mm]	L+brake with opt. encoder G6.1x [mm]
LST-097-1	146	178	183	215	167	199
LST-097-2	161	193	198	230	182	214
LST-097-3	176	208	213	245	197	229
LST-097-4	221	253	258	290	242	274
LST-097-5	276	308	313	345	297	329

Motor type	L with opt. encoder G6.2x [mm]	L+brake with opt. encoder G6.2x [mm]	L with opt. encoder G6.3x [mm]	L+brake with opt. encoder G6.3x [mm]	L with opt. encoder G3/G5 [mm]	L+brake with opt. encoder G3/G5 [mm]
LST-097-1	165	197	146	178	176	208
LST-097-2	–	212	161	193	In preparation	In preparation
LST-097-3	195	227	176	208	206	238
LST-097-4	240	272	221	253	251	283
LST-097-5	–	327	276	308	In preparation	In preparation

Table: Overview of motor lengths – for overview of encoder types see section 5.1

Technical data <sup>1)</sup>	Symbol	LST-097-1-30-320	LST-097-2-30-320	LST-097-3-30-320	LST-097-4-30-320	LST-097-5-30-320
Rated speed	$n_n$	3000 rpm	3000 rpm	3000 rpm	3000 rpm	3000 rpm
Rated frequency	$f_N$	150 Hz	150 Hz	150 Hz	150 Hz	150 Hz
DC link voltage (controller)	$U_{dc}$	320 V	320 V	320 V	320 V	320 V
Rated voltage	$U_n$	200 V	200 V	200 V	200 V	200 V
Rated torque	$M_n$	2.3 Nm	3.3 Nm	4.6 Nm	6.4 Nm	8.5 Nm
Rated current	$I_n$	3.0 A	4.3 A	5.9 A	8.1 A	10.5 A
Rated power	$P$	0.72 kW	1.0 kW	1.44 kW	2.0 kW	2.67 kW
Stall torque	$M_0$	2.6 Nm	3.9 Nm	5.3 Nm	7.5 Nm	9.5 Nm
Stall current	$I_0$	3.1 A	4.8 A	6.5 A	9.1 A	11.3 A
Maximum permissible torque	$M_{max}$	10.4 Nm	15.6 Nm	21 Nm	30 Nm	38 Nm
Maximum permissible current	$I_{max}$	18.9 A	29 A	39.0 A	54 A	68 A
Maximum permissible speed	$n_{max}$	12000 rpm	12000 rpm	12000 rpm	12000 rpm	12000 rpm
Voltage constant	$K_E$	50.0 V/ 1000 rpm	49.0 V/ 1000 rpm	49.5 V/ 1000 rpm	50.0 V/ 1000 rpm	51.0 V/ 1000 rpm
Torque constant	$K_T$	0.83 Nm/A	0.81 Nm/A	0.82 Nm/A	0.83 Nm/A	0.84 Nm/A
Winding resistance (2 phases)	$R_{2ph}$	3.6 $\Omega$	2.3 $\Omega$	1.66 $\Omega$	0.87 $\Omega$	0.59 $\Omega$
Winding inductance (2 phases)	$L_{2ph}$	15.9 mH	11.8 mH	9.8 mH	5.6 mH	4.1 mH
No load speed	$n_0$	4000 rpm	4080 rpm	4040 rpm	4000 rpm	3920 rpm
Electrical time constant	$T_{el}$	4.4 ms	5.2 ms	5.9 ms	6.4 ms	6.9 ms
Thermal time constant	$T_{th}$	60 min.	65 min.	64 min.	66 min.	68 min.
Moment of inertia of the motor	$J$	0.00019 kgm <sup>2</sup>	0.00023 kgm <sup>2</sup>	0.00027 kgm <sup>2</sup>	0.00042 kgm <sup>2</sup>	0.00061 kgm <sup>2</sup>
Mass	$m$	4.5 kg	5.05 kg	5.6 kg	7.7 kg	10.5 kg

#### Brake (optional)

Rated voltage	$U_N$	24 V $\pm$ 10 %
Rated current at 20 °C for venting	$I_N$	0.75 A
Permissible maximum speed	$n_{max}$	10000 rpm
Permissible friction energy	$W_R$	0.89 x 10 <sup>6</sup> Ws
Mass moment of inertia	$J_B$	0.000054 kgm <sup>2</sup>
Mass	$m$	0.46 kg
Braking torque	$M_H$	9.0 Nm

1) All values with a tolerance of  $\pm$  10%.

### 3.20.2 Characteristics

Explanations of characteristics:

The characteristic  $M_{\max}$  describes the maximum possible short-time torque at corresponding speed. It is important for dynamic processes.

The characteristic  $M_n$  indicates the thermally permissible rated torque.

The characteristics are limited by the respective maximum permissible speed  $n_{\max}$  (for  $n_{\max}$  refer to the "Technical data" table).

3

#### LST-097-1-30-320

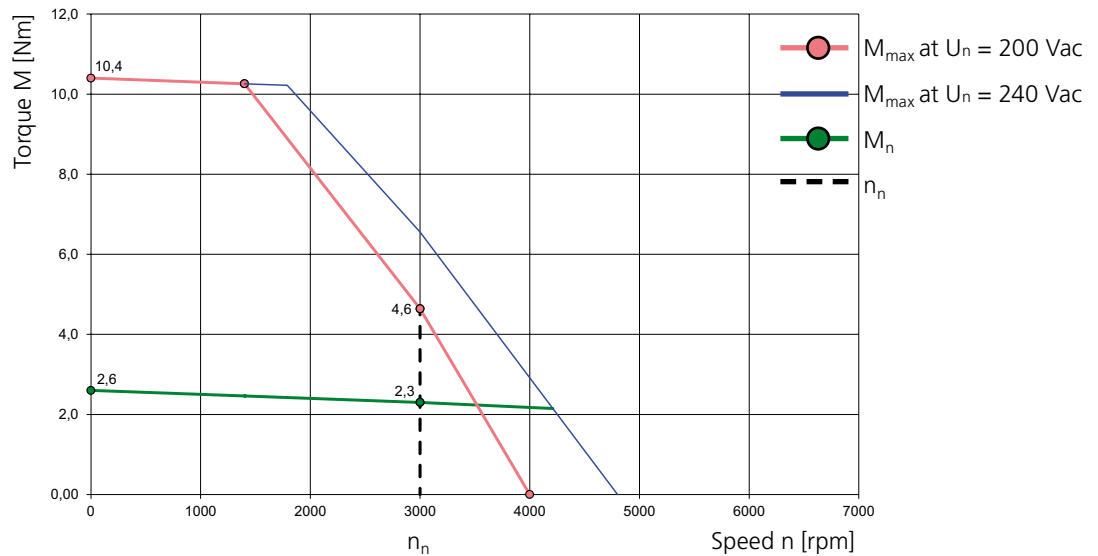

#### LST-097-2-30-320

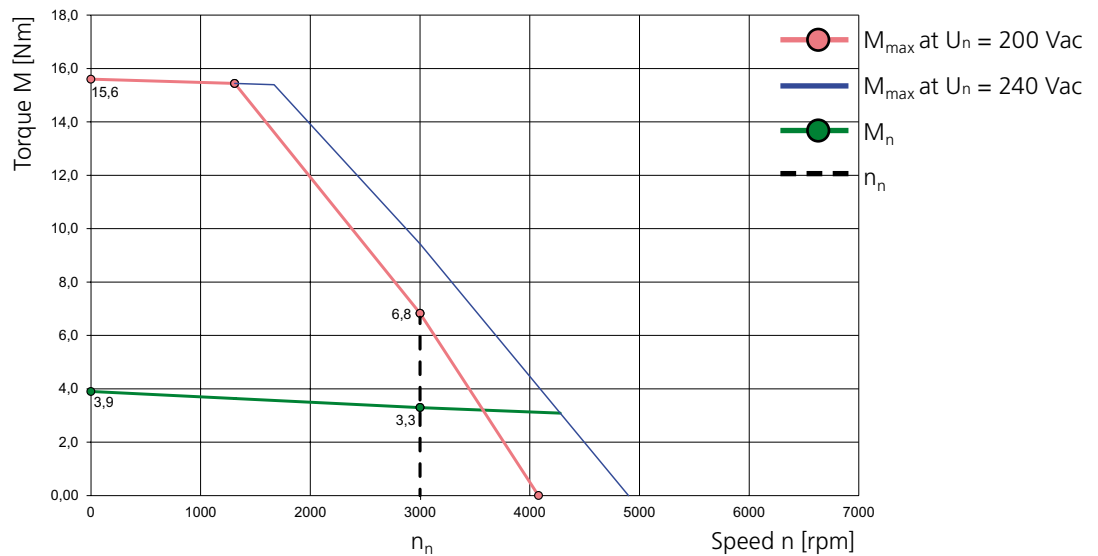

### LST-097-3-30-320

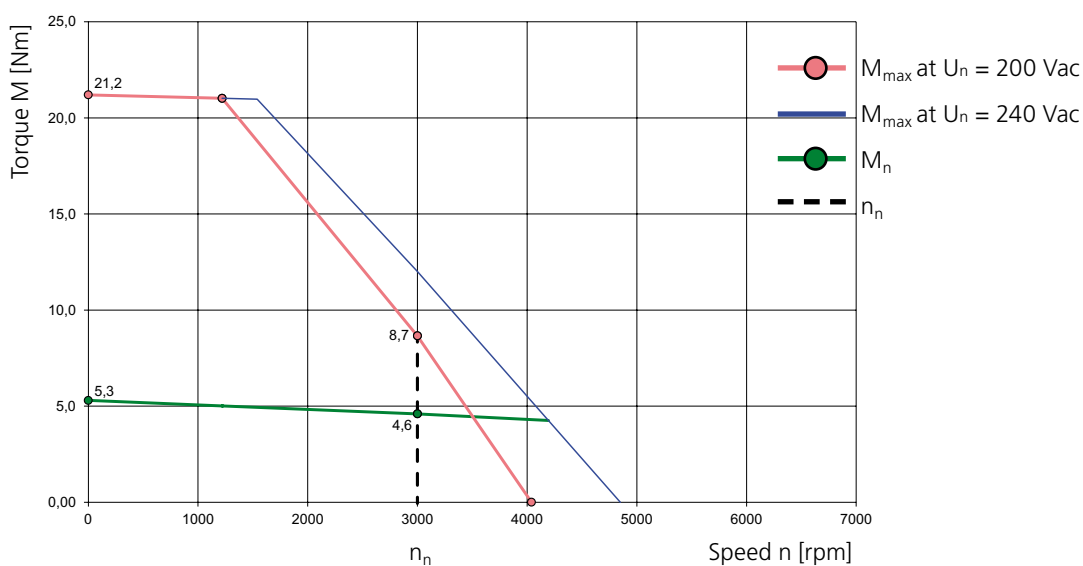

### LST-097-4-30-320

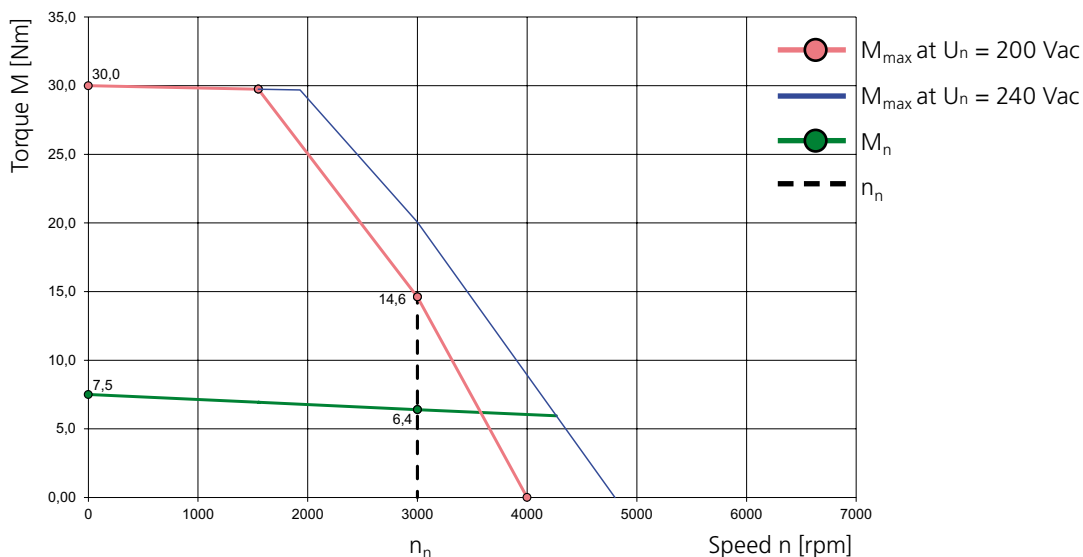

### LST-097-5-30-320

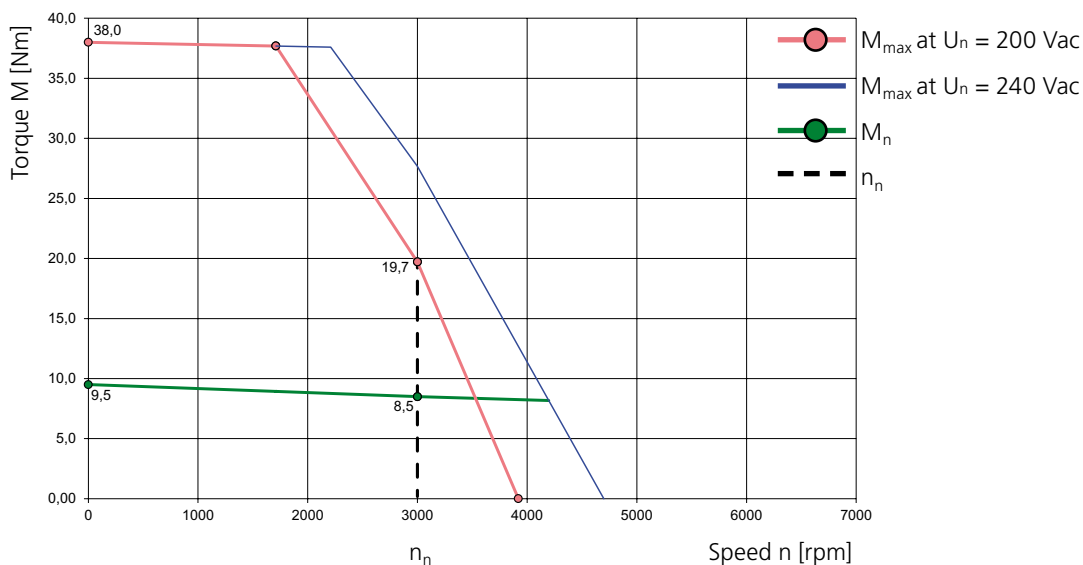

### 3.21 Motor type: LST-097 ( $U_{dc} = 560 \text{ V}$ )



#### 3.21.1 Dimensional sketch and technical data

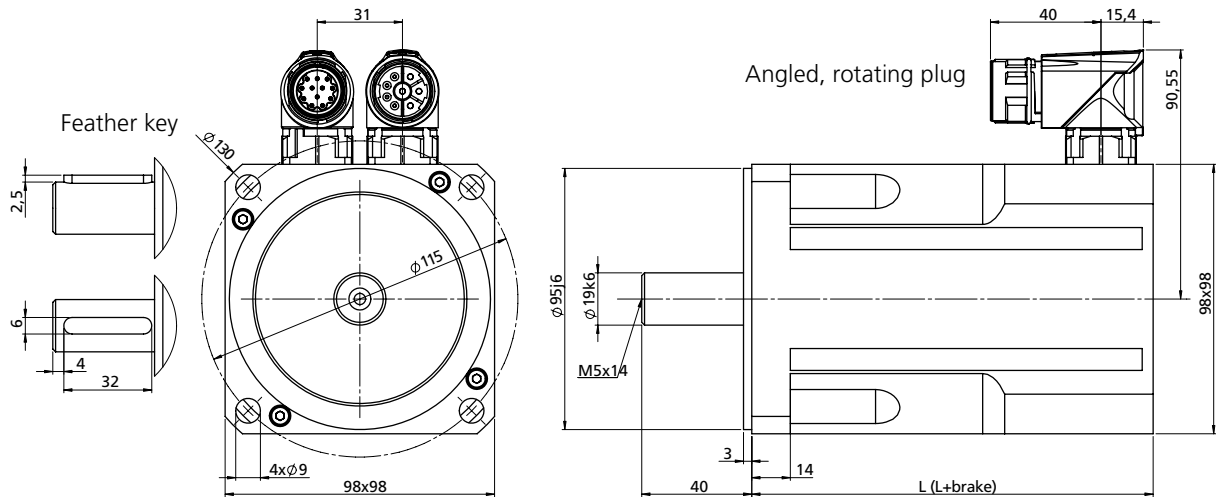

Motor type	L with resolver xR [mm]	L+brake with resolver xR [mm]	L with opt. encoder G12.xy [mm]	L+brake with opt. encoder G12.xy [mm]	L with opt. encoder G6.1x [mm]	L+brake with opt. encoder G6.1x [mm]
LST-097-1	146	178	183	215	167	199
LST-097-2	161	193	198	230	182	214
LST-097-3	176	208	213	245	197	229
LST-097-4	221	253	258	290	242	274
LST-097-5	276	308	313	345	297	329

Motor type	L with opt. encoder G6.2x [mm]	L+brake with opt. encoder G6.2x [mm]	L with opt. encoder G6.3x [mm]	L+brake with opt. encoder G6.3x [mm]	L with opt. encoder G3/G5 [mm]	L+brake with opt. encoder G3/G5 [mm]
LST-097-1	165	197	146	178	176	208
LST-097-2	–	212	161	193	In preparation	In preparation
LST-097-3	195	227	176	208	206	238
LST-097-4	240	272	221	253	251	283
LST-097-5	–	327	276	308	In preparation	In preparation

Table: Overview of motor lengths – for overview of encoder types see section 5.1



Technical data <sup>1)</sup>	Symbol	LST-097-1-30-560	LST-097-2-30-560	LST-097-3-30-560	LST-097-4-30-560	LST-097-5-30-560
Rated speed	$n_n$	3000 rpm	3000 rpm	3000 rpm	3000 rpm	3000 rpm
Rated frequency	$f_N$	150 Hz	150 Hz	150 Hz	150 Hz	150 Hz
DC link voltage (controller)	$U_{dc}$	560 V	560 V	560 V	560 V	560 V
Rated voltage	$U_n$	330 V	330 V	330 V	330 V	330 V
Rated torque	$M_n$	2.3 Nm	3.3 Nm	4.6 Nm	6.4 Nm	8.5 Nm
Rated current	$I_n$	1.85 A	2.6 A	3.8 A	4.4 A	6.2 A
Rated power	$P$	0.72 kW	1.0 kW	1.44 kW	2.0 kW	2.67 kW
Stall torque	$M_0$	2.6 Nm	3.9 Nm	5.3 Nm	7.5 Nm	9.5 Nm
Stall current	$I_0$	1.92 A	2.9 A	4.1 A	4.8 A	6.6 A
Maximum permissible torque	$M_{max}$	10.4 Nm	15.6 Nm	21.0 Nm	30.0 Nm	38 Nm
Maximum permissible current	$I_{max}$	11.5 A	17.3 A	25.0 A	29 A	40 A
Maximum permissible speed	$n_{max}$	12000 rpm	12000 rpm	12000 rpm	12000 rpm	12000 rpm
Voltage constant	$K_E$	82.0 V/ 1000 rpm	82.0 V/ 1000 rpm	78.0 V/ 1000 rpm	94.0 V/ 1000 rpm	87.0 V/ 1000 rpm
Torque constant	$K_T$	1.36 Nm/A	1.36 Nm/A	1.29 Nm/A	1.55 Nm/A	1.44 Nm/A
Winding resistance (2 phases)	$R_{2ph}$	9.6 $\Omega$	6.3 $\Omega$	4.2 $\Omega$	3.0 $\Omega$	1.65 $\Omega$
Winding inductance (2 phases)	$L_{2ph}$	41.5 mH	33.1 mH	24.0 mH	19.2 mH	11.7 mH
No load speed	$n_0$	4020 rpm	4020 rpm	4230 rpm	3510 rpm	3790 rpm
Electrical time constant	$T_{el}$	4.3 ms	5.3 ms	5.7 ms	6.4 ms	7.1 ms
Thermal time constant	$T_{th}$	60 min.	65 min.	64 min.	66 min.	68 min.
Moment of inertia of the motor	$J$	0.00019 kgm <sup>2</sup>	0.00023 kgm <sup>2</sup>	0.00027 kgm <sup>2</sup>	0.00042 kgm <sup>2</sup>	0.00061 kgm <sup>2</sup>
Mass	$m$	4.5 kg	5.05 kg	5.6 kg	7.7 kg	10.5 kg

#### Brake (optional)

Rated voltage	$U_N$	24 V $\pm$ 10 %
Rated current at 20 °C for venting	$I_N$	0.75 A
Permissible maximum speed	$n_{max}$	10000 rpm
Permissible friction energy	$W_R$	0.89 x 10 <sup>6</sup> Ws
Mass moment of inertia	$J_B$	0.000054 kgm <sup>2</sup>
Mass	$m$	0.46 kg
Braking torque	$M_H$	9.0 Nm

1) All values with a tolerance of  $\pm$  10%.

### 3.21.2 Characteristics

Explanations of characteristics:

The characteristic  $M_{max}$  describes the maximum possible short-time torque at corresponding speed. It is important for dynamic processes.

The characteristic  $M_n$  indicates the thermally permissible rated torque.

The characteristics are limited by the respective maximum permissible speed  $n_{max}$  (for  $n_{max}$  refer to the "Technical data" table).

3

#### LST-097-1-30-560

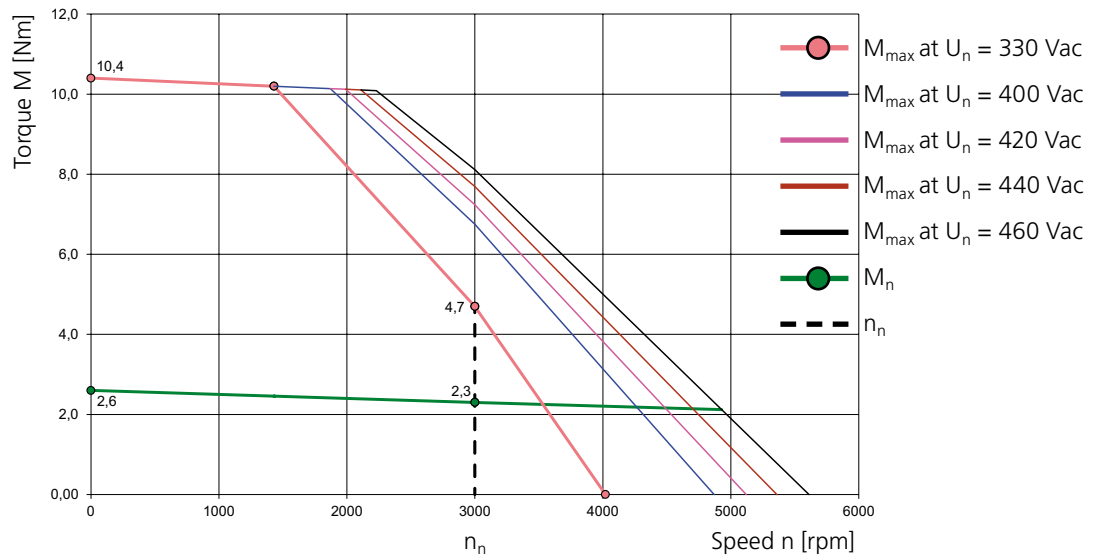

#### LST-097-2-30-560

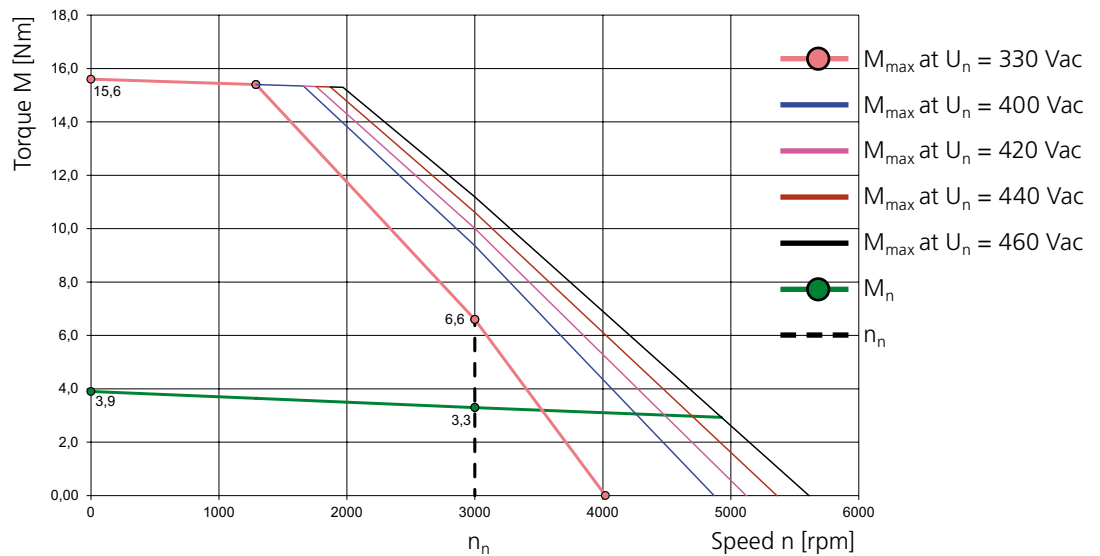

### LST-097-3-30-560

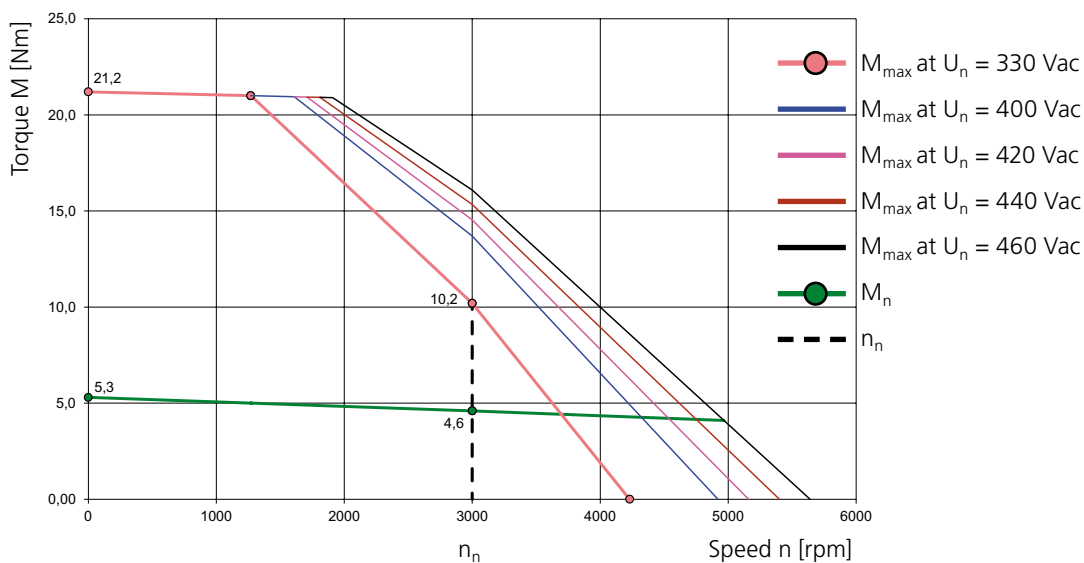

### LST-097-4-30-560

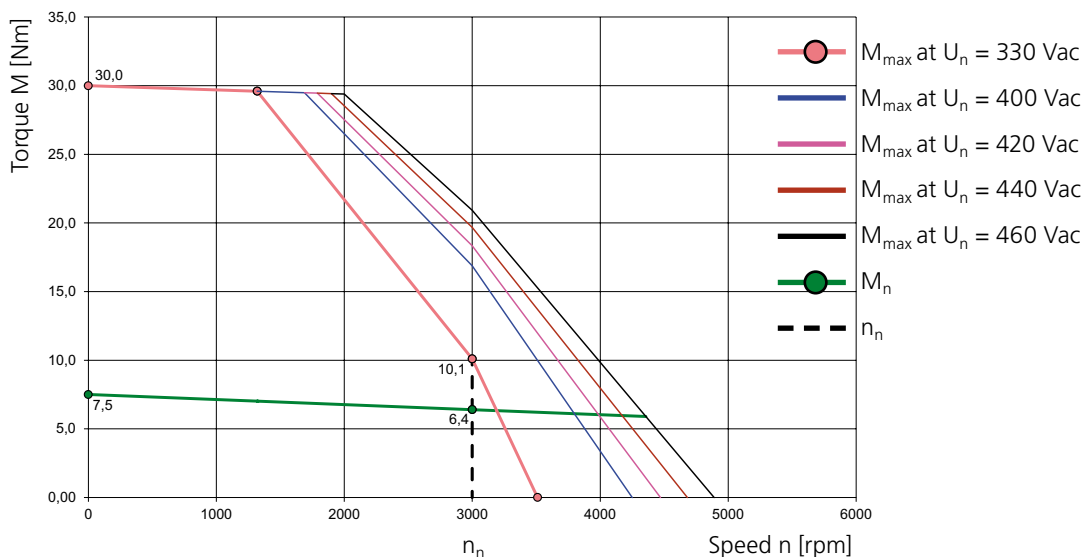

### LST-097-5-30-560

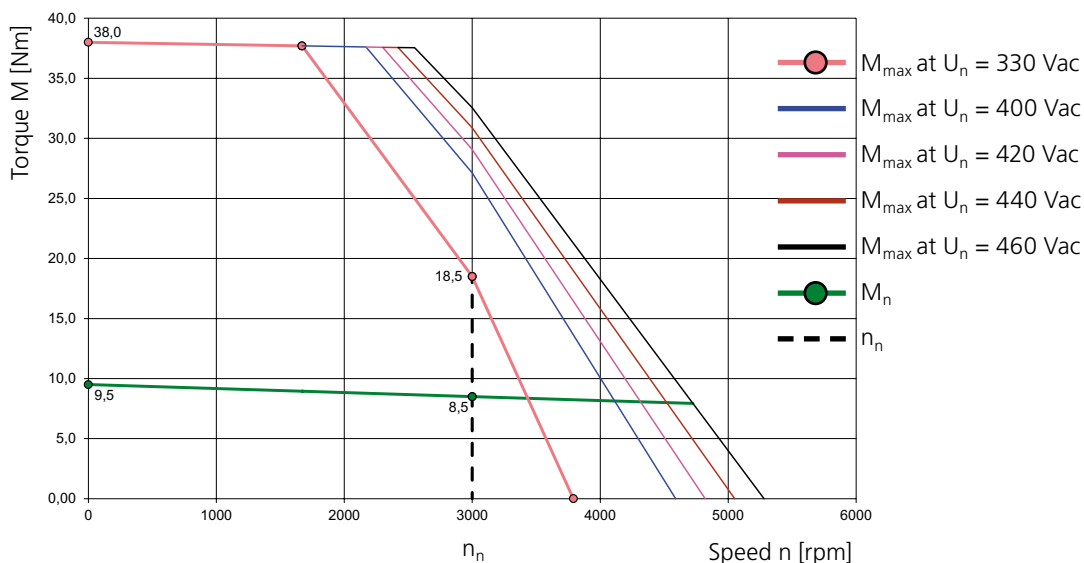



Technical data <sup>1)</sup>	Symbol	LST-127-1-30-560	LST-127-2-30-560	LST-127-3-30-560	LST-127-4-30-560	LST-127-5-30-560
Rated speed	$n_n$	3000 rpm	3000 rpm	3000 rpm	3000 rpm	3000 rpm
Rated frequency	$f_N$	150 Hz	150 Hz	150 Hz	150 Hz	150 Hz
DC link voltage (controller)	$U_{dc}$	560 V	560 V	560 V	560 V	560 V
Rated voltage	$U_n$	330 V	330 V	330 V	330 V	330 V
Rated torque	$M_n$	5.7 Nm	8.8 Nm	11.0 Nm	14.0 Nm	17.0 Nm
Rated current	$I_n$	4.0 A	6.3 A	9.5 A	10.0 A	13.0 A
Rated power	$P$	1.79 kW	2.76 kW	3.45 kW	4.55 kW	5.33 kW
Stall torque	$M_0$	6.6 Nm	10.5 Nm	13.5 Nm	17.0 Nm	22.0 Nm
Stall current	$I_0$	4.5 A	7.3 A	11.2 A	11.4 A	16.4 A
Maximum permissible torque	$M_{max}$	19.8 Nm	32 Nm	41 Nm	51 Nm	66 Nm
Maximum permissible current	$I_{max}$	23 A	36 A	56 A	47 A	82 A
Maximum permissible speed	$n_{max}$	9000 rpm	9000 rpm	9000 rpm	9000 rpm	9000 rpm
Voltage constant	$K_E$	88.0 V/ 1000 rpm	87.0 V/ 1000 rpm	73.0 V/ 1000 rpm	90.0 V/ 1000 rpm	81.0 V/ 1000 rpm
Torque constant	$K_T$	1.46 Nm/A	1.44 Nm/A	1.21 Nm/A	1.49 Nm/A	1.34 Nm/A
Winding resistance (2 phases)	$R_{2ph}$	4.20 $\Omega$	1.70 $\Omega$	0.95 $\Omega$	0.95 $\Omega$	0.54 $\Omega$
Winding inductance (2 phases)	$L_{2ph}$	27.8 mH	15.2 mH	9.0 mH	10.0 mH	5.9 mH
No load speed	$n_0$	3750 rpm	3790 rpm	4520 rpm	3670 rpm	4070 rpm
Electrical time constant	$T_{el}$	6.7 ms	8.9 ms	9.5 ms	10.5 ms	10.9 ms
Thermal time constant	$T_{th}$	45 min.	50 min.	55 min.	60 min.	75 min.
Moment of inertia of the motor	$J$	0.0004 kgm <sup>2</sup>	0.00062 kgm <sup>2</sup>	0.00075 kgm <sup>2</sup>	0.00095 kgm <sup>2</sup>	0.00117 kgm <sup>2</sup>
Mass	$m$	7.5 kg	10.0 kg	11.2 kg	13.7 kg	16.2 kg

#### Brake (optional)

Rated voltage	$U_N$	24 V $\pm$ 10 %
Rated current at 20 °C for venting	$I_N$	1.0 A
Permissible maximum speed	$n_{max}$	10000 rpm
Permissible friction energy	$W_R$	1.29 x 10 <sup>6</sup> Ws
Mass moment of inertia	$J_B$	0.000166 kgm <sup>2</sup>
Mass	$m$	0.9 kg
Braking torque	$M_H$	18.0 Nm

1) All values with a tolerance of  $\pm$  10%.

### 3.22.2 Characteristics

Explanations of characteristics:

The characteristic  $M_{max}$  describes the maximum possible short-time torque at corresponding speed. It is important for dynamic processes.

The characteristic  $M_n$  indicates the thermally permissible rated torque.

The characteristics are limited by the respective maximum permissible speed  $n_{max}$  (for  $n_{max}$  refer to the "Technical data" table).

3

#### LST-127-1-30-560

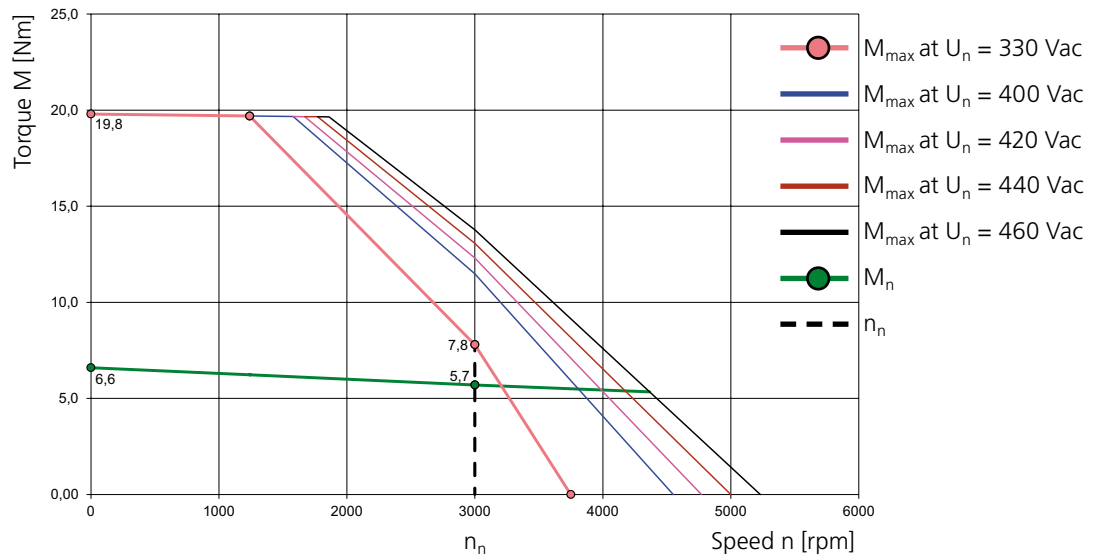

#### LST-127-2-30-560

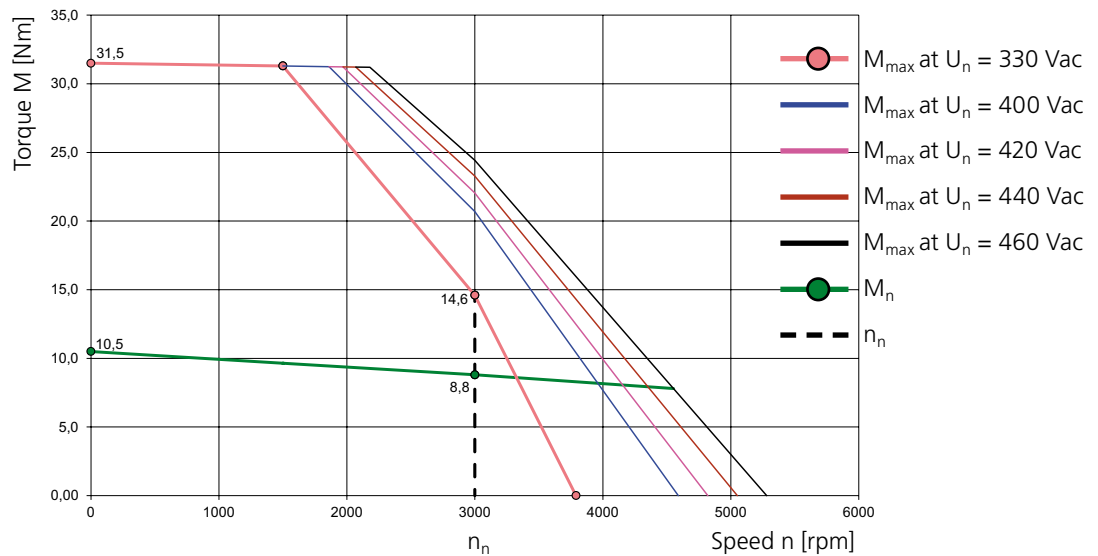

### LST-127-3-30-560

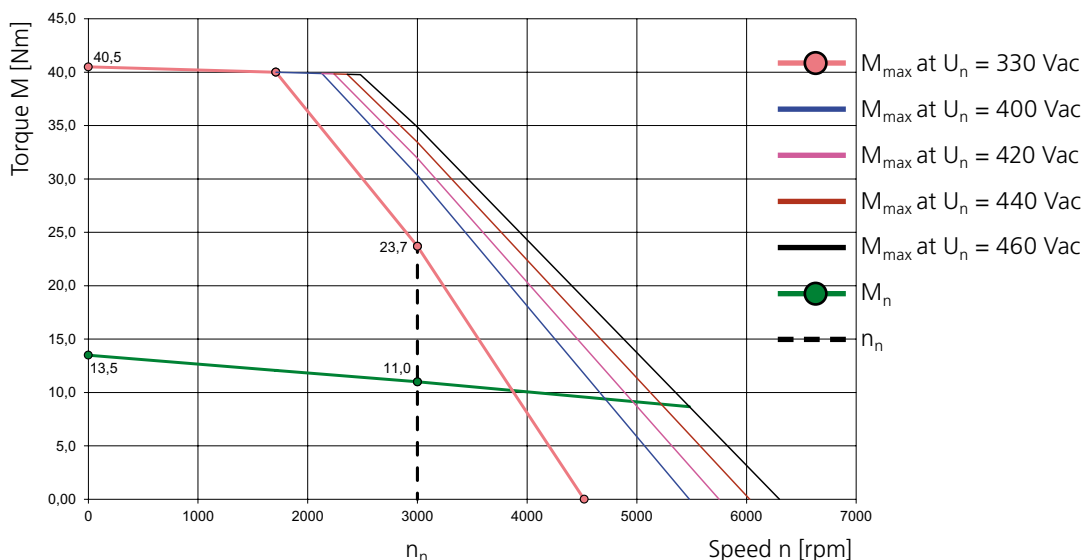

### LST-127-4-30-560

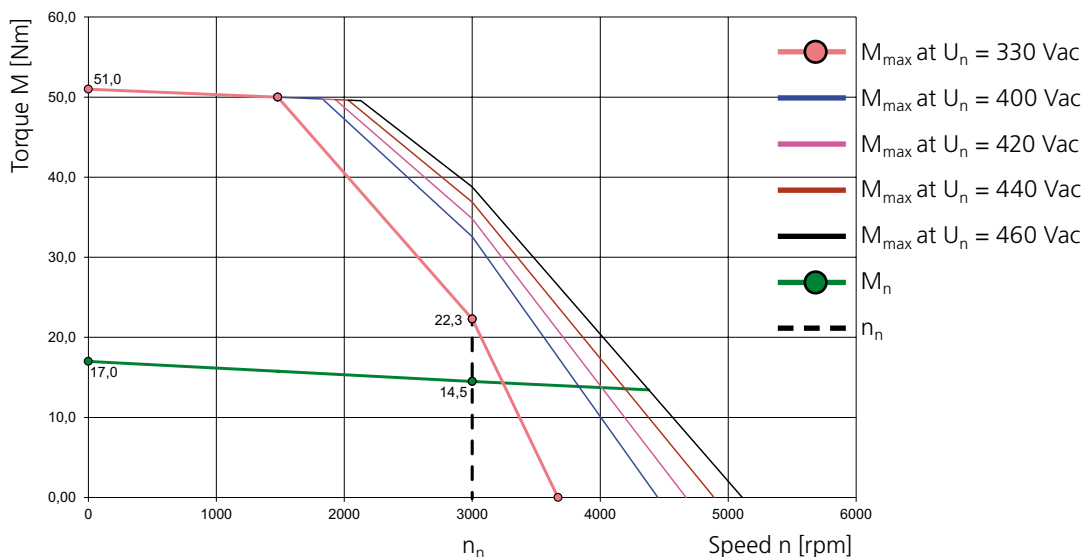

### LST-127-5-30-560

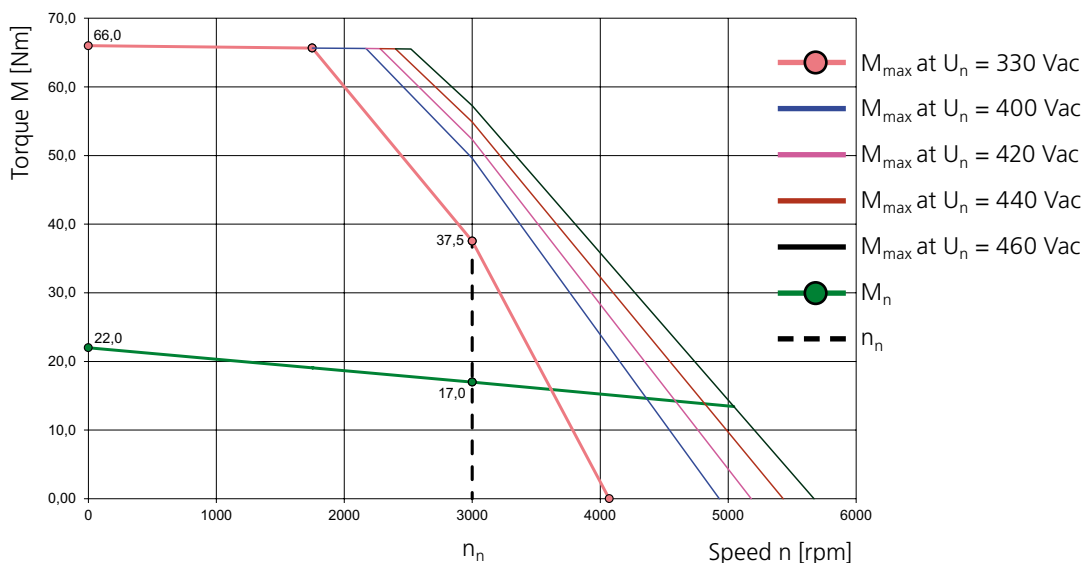

### 3.23 Motor type: LST-158 ( $U_{dc} = 560 \text{ V}$ )



#### 3.23.1 Dimensional sketch and technical data

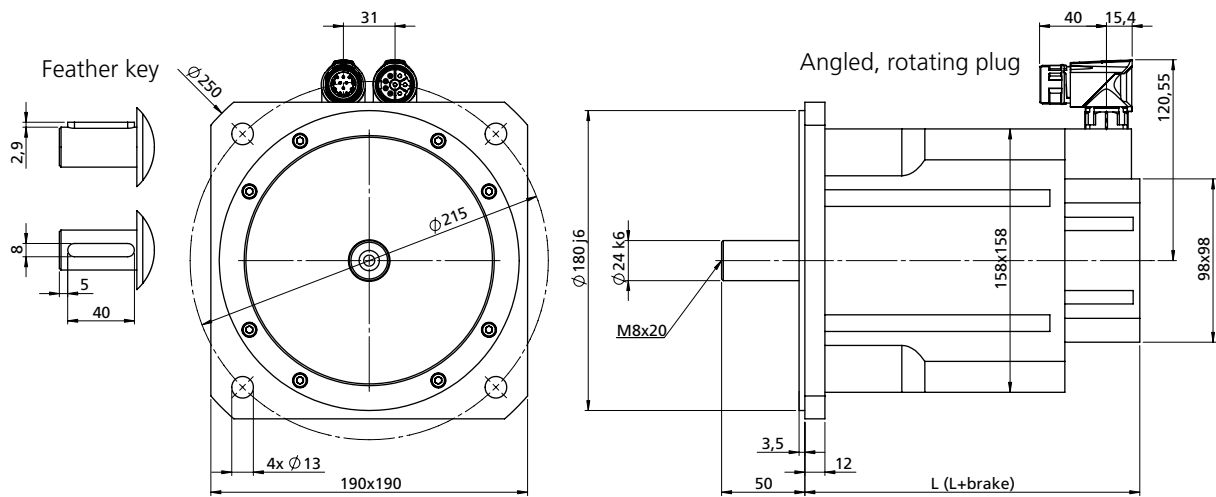

Motor type	L with resolver xR [mm]	L+brake with resolver xR [mm]	L with opt. encoder G12.xy [mm]	L+brake with opt. encoder G12.xy [mm]	L with opt. encoder G6.1x [mm]	L+brake with opt. encoder G6.1x [mm]
LST-158-1	201	254	221	274	204	257
LST-158-2	235	288	255	308	238	291
LST-158-3	252	305	272	325	255	308
LST-158-4	310	356	330	376	313	359
LST-158-5	395	448	415	468	398	451

Motor type	L with opt. encoder G6.2x [mm]	L+brake with opt. encoder G6.2x [mm]	L with opt. encoder G6.3x [mm]	L+brake with opt. encoder G6.3x [mm]	L with opt. encoder G3/G5 [mm]	L+brake with opt. encoder G3/G5 [mm]
LST-158-1	In preparation	In preparation	In preparation	In preparation	In preparation	In preparation
LST-158-2	In preparation	In preparation	In preparation	In preparation	In preparation	In preparation
LST-158-3	In preparation	In preparation	In preparation	In preparation	In preparation	In preparation
LST-158-4	In preparation	In preparation	In preparation	In preparation	In preparation	In preparation
LST-158-5	In preparation	In preparation	In preparation	In preparation	In preparation	In preparation

Table: Overview of motor lengths – for overview of encoder types see section 5.1



Technical data <sup>1)</sup>	Symbol	LST-158-1-30-560	LST-158-2-30-560	LST-158-3-30-560	LST-158-4-30-560	LST-158-5-30-560
Rated speed	$n_n$	3000 rpm	3000 rpm	3000 rpm	3000 rpm	3000 rpm
Rated frequency	$f_N$	150 Hz	150 Hz	150 Hz	150 Hz	150 Hz
DC link voltage (controller)	$U_{dc}$	560 V	560 V	560 V	560 V	560 V
Rated voltage	$U_n$	330 V	330 V	330 V	330 V	330 V
Rated torque	$M_n$	13.0 Nm	17.0 Nm	19.0 Nm	24.0 Nm	26.0 Nm
Rated current	$I_n$	8.2 A	10.6 A	13.1 A	14.7 A	18.2 A
Rated power	$P$	4.0 kW	5.33 kW	6.0 kW	7.53 kW	8.16 kW
Stall torque	$M_0$	13.5 Nm	19.0 Nm	22.0 Nm	29.0 Nm	35.0 Nm
Stall current	$I_0$	8.2 A	11.5 A	14.6 A	17.2 A	23.5 A
Maximum permissible torque	$M_{max}$	47 Nm	67 Nm	77 Nm	102 Nm	105 Nm
Maximum permissible current	$I_{max}$	40 A	56 A	72 A	84 A	99 A
Maximum permissible speed	$n_{max}$	6000 rpm	6000 rpm	6000 rpm	6000 rpm	6000 rpm
Voltage constant	$K_E$	100.0 V/ 1000 rpm	100.0 V/ 1000 rpm	91.0 V/ 1000 rpm	102.0 V/ 1000 rpm	90.0 V/ 1000 rpm
Torque constant	$K_T$	1.65 Nm/A	1.65 Nm/A	1.51 Nm/A	1.69 Nm/A	1.49 Nm/A
Winding resistance (2 phases)	$R_{2ph}$	1.10 $\Omega$	0.61 $\Omega$	0.41 $\Omega$	0.31 $\Omega$	0.16 $\Omega$
Winding inductance (2 phases)	$L_{2ph}$	13.5 mH	9.0 mH	6.4 mH	5.6 mH	3.2 mH
No load speed	$n_0$	3500 rpm	3500 rpm	3400 rpm	3430 rpm	3660 rpm
Electrical time constant	$T_{el}$	12.3 ms	14.8 ms	15.6 ms	18.1 ms	19.9 ms
Thermal time constant	$T_{th}$	45 min.	53 min.	60 min.	70 min.	80 min.
Moment of inertia of the motor	$J$	0.00131 kgm <sup>2</sup>	0.00187 kgm <sup>2</sup>	0.0022 kgm <sup>2</sup>	0.0033 kgm <sup>2</sup>	0.0046 kgm <sup>2</sup>
Mass	$m$	13.9 kg	18.2 kg	20.3 kg	26.7 kg	35.2 kg

#### Brake (optional)

Rated voltage	$U_N$	24 V $\pm$ 10 %
Rated current at 20 °C for venting	$I_N$	1.1 A
Permissible maximum speed	$n_{max}$	10000 rpm
Permissible friction energy	$W_R$	2.90 x 10 <sup>6</sup> Ws
Mass moment of inertia	$J_B$	0.000556 kgm <sup>2</sup>
Mass	$m$	1.6 kg
Braking torque	$M_H$	36.0 Nm

1) All values with a tolerance of  $\pm$  10%.

### 3.23.2 Characteristics

Explanations of characteristics:

The characteristic  $M_{max}$  describes the maximum possible short-time torque at corresponding speed. It is important for dynamic processes.

The characteristic  $M_n$  indicates the thermally permissible rated torque.

The characteristics are limited by the respective maximum permissible speed  $n_{max}$  (for  $n_{max}$  refer to the "Technical data" table).

3

#### LST-158-1-30-560

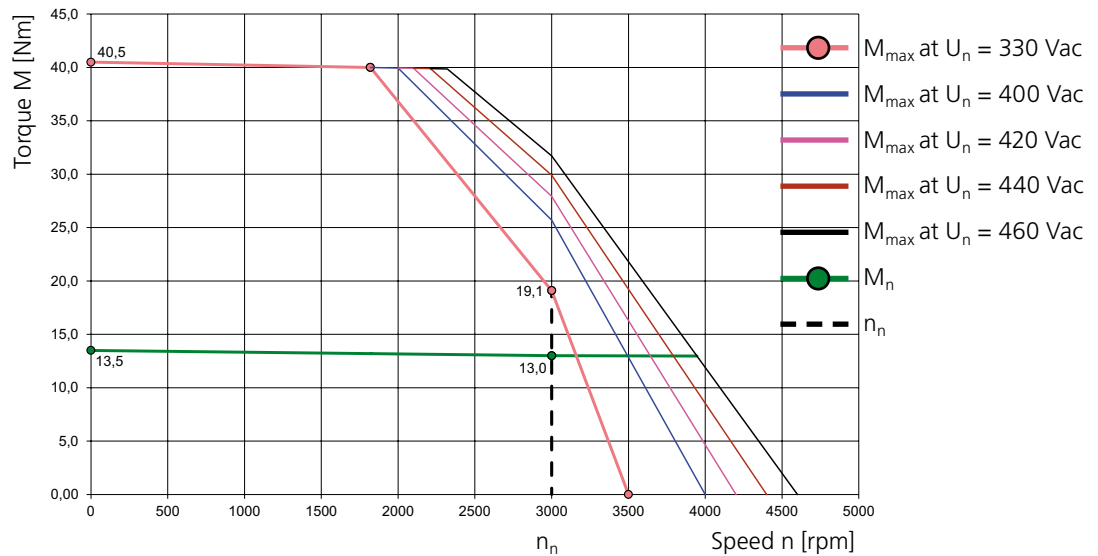

#### LST-158-2-30-560

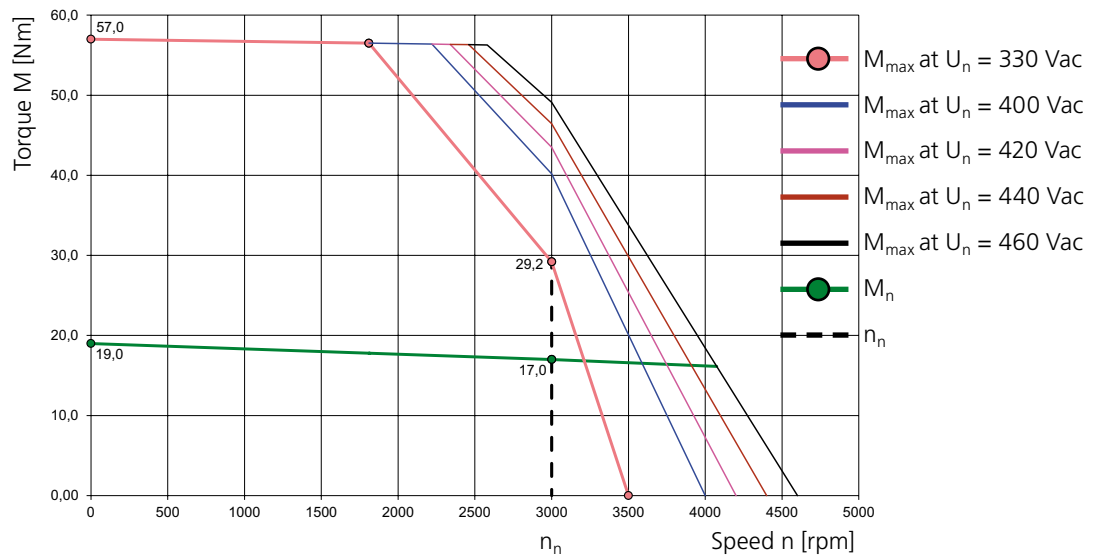

### LST-158-3-30-560

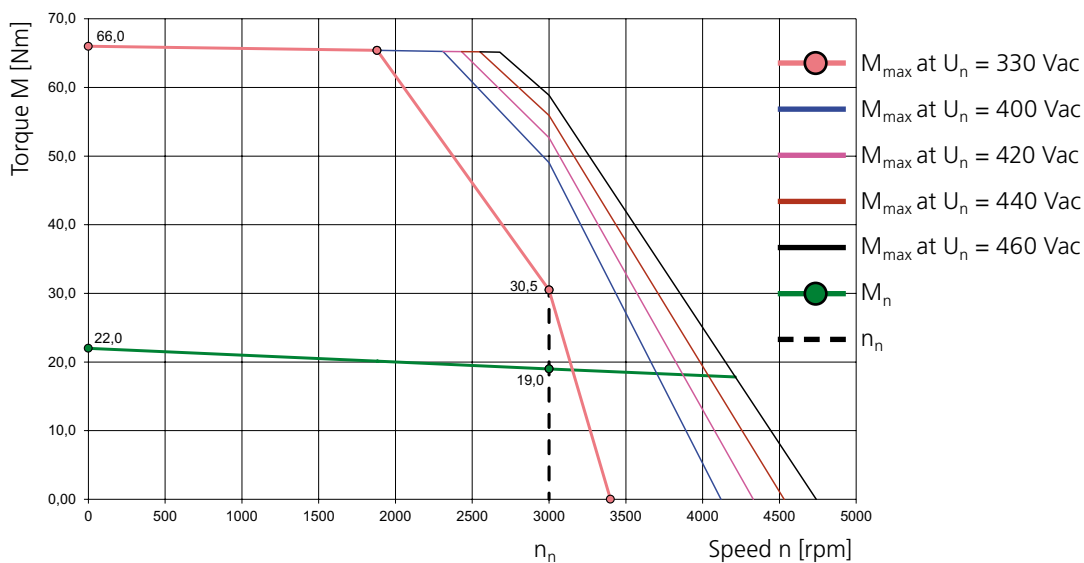

### LST-158-4-30-560

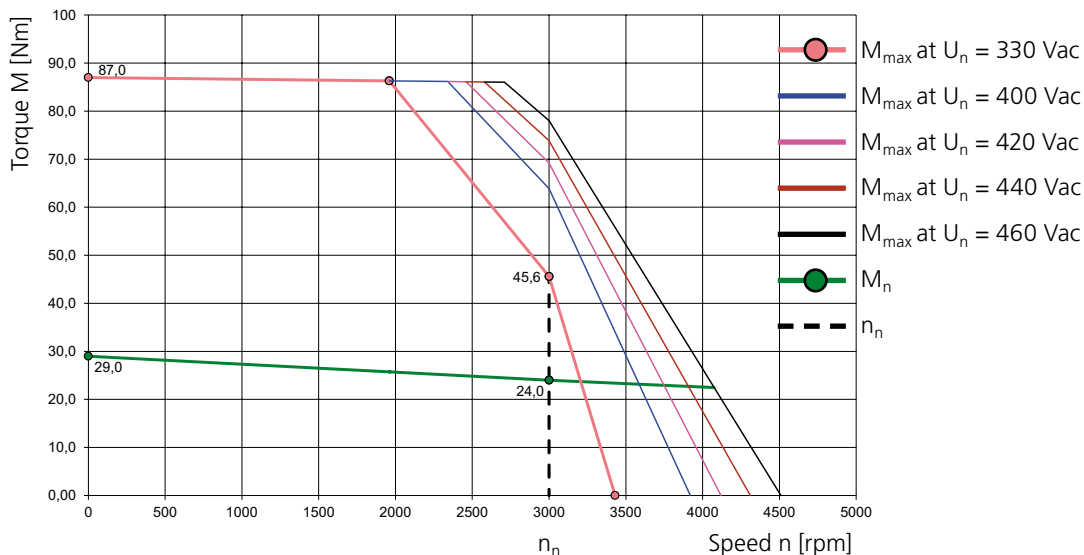

### LST-158-5-30-560

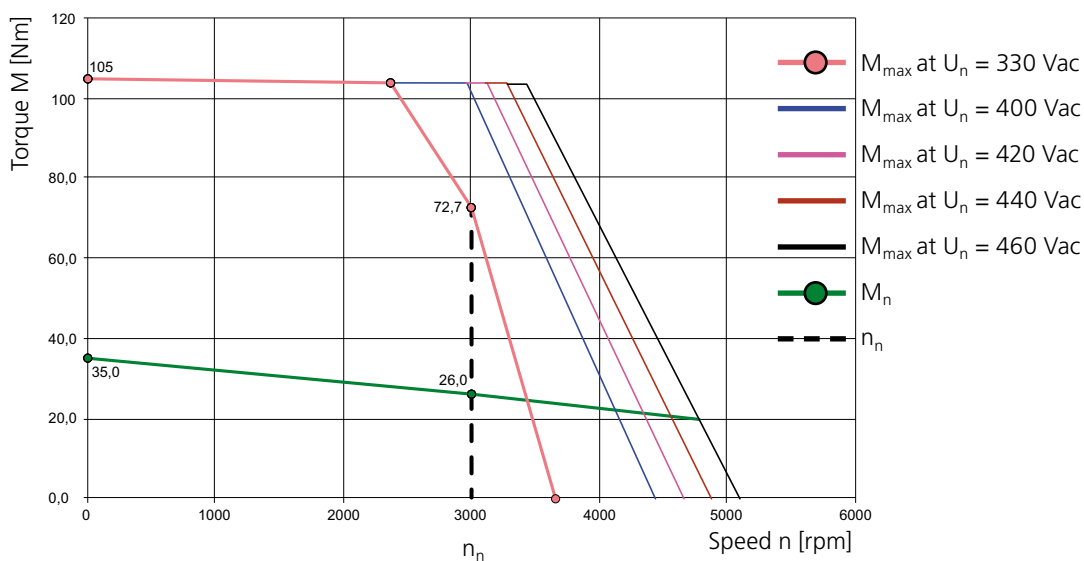

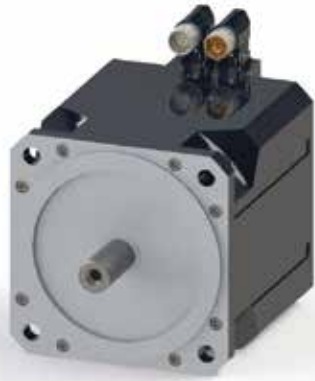

### 3.24 Motor type: LST-190 ( $U_{dc} = 560\text{ V}$ )

#### 3.24.1 Dimensional sketch and technical data

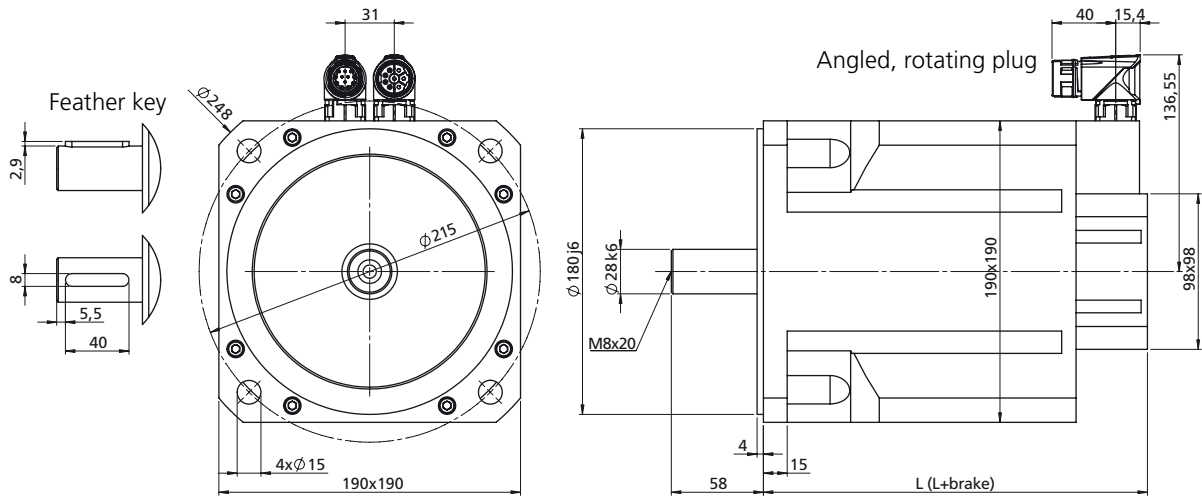

Motor type	L with resolver xR [mm]	L+brake with resolver xR [mm]	L with opt. encoder G12.xy [mm]	L+brake with opt. encoder G12.xy [mm]	L with opt. encoder G6.1x [mm]	L+brake with opt. encoder G6.1x [mm]
LST-190-1	242	296	262	316	245	299
LST-190-2	257	311	277	331	260	314
LST-190-3	287	341	307	361	290	344

Motor type	L with opt. encoder G6.2x [mm]	L+brake with opt. encoder G6.2x [mm]	L with opt. encoder G6.3x [mm]	L+brake with opt. encoder G6.3x [mm]	L with opt. encoder G3/G5 [mm]	L+brake with opt. encoder G3/G5 [mm]
LST-190-1	In preparation	296	In preparation	In preparation	In preparation	In preparation
LST-190-2	In preparation	311	In preparation	In preparation	In preparation	In preparation
LST-190-3	In preparation	341	In preparation	In preparation	In preparation	In preparation

Table: Overview of motor lengths – for overview of encoder types see section 5.1

Technical data <sup>1)</sup>	Symbol	LST-190-1-30-560	LST-190-2-30-560	LST-190-3-30-560
Rated speed	$n_n$	3000 rpm	3000 rpm	3000 rpm
Rated frequency	$f_N$	150 Hz	150 Hz	150 Hz
DC link voltage (controller)	$U_{dc}$	560 V	560 V	560 V
Rated voltage	$U_n$	330 V	330 V	330 V
Rated torque	$M_n$	21.0 Nm	23.0 Nm	26.0 Nm
Rated current	$I_n$	13.5 A	15.0 A	17.9 A
Rated power	$P$	6.6 kW	7.22 kW	8.16 kW
Stall torque	$M_0$	27.0 Nm	32.0 Nm	40.0 Nm
Stall current	$I_0$	16.0 A	19.0 A	24.7 A
Maximum permissible torque	$M_{max}$	81 Nm	96 Nm	120 Nm
Maximum permissible current	$I_{max}$	62 A	74 A	96 A
Maximum permissible speed	$n_{max}$	6000 rpm	6000 rpm	6000 rpm
Voltage constant	$K_E$	102.0 V/1000 rpm	102.0 V/1000 rpm	98.0 V/1000 rpm
Torque constant	$K_T$	1.69 Nm/A	1.69 Nm/A	1.62 Nm/A
Winding resistance (2 phases)	$R_{2ph}$	0.43 $\Omega$	0.35 $\Omega$	0.23 $\Omega$
Winding inductance (2 phases)	$L_{2ph}$	4.4 mH	3.8 mH	2.7 mH
No load speed	$n_0$	3230 rpm	3230 rpm	3360 rpm
Electrical time constant	$T_{el}$	10.2 ms	10.9 ms	11.7 ms
Thermal time constant	$T_{th}$	60 min.	67 min.	67 min.
Moment of inertia of the motor	$J$	0.0036 kgm <sup>2</sup>	0.0039 kgm <sup>2</sup>	0.0046 kgm <sup>2</sup>
Mass	$m$	23.5 kg	26.0 kg	31.5 kg

#### Brake (optional)

Rated voltage	$U_N$	24 V $\pm$ 10 %
Rated current at 20 °C for venting	$I_N$	1.1 A
Permissible maximum speed	$n_{max}$	10000 rpm
Permissible friction energy	$W_R$	2.9 10 <sup>6</sup> Ws
Mass moment of inertia	$J_B$	0.00062 kgm <sup>2</sup>
Mass	$m$	3.2 kg
Braking torque	$M_H$	36 Nm

<sup>1)</sup> All values with a tolerance of  $\pm$  10%.

### 3.24.2 Characteristics

Explanations of characteristics:

The characteristic  $M_{max}$  describes the maximum possible short-time torque at corresponding speed. It is important for dynamic processes.

The characteristic  $M_n$  indicates the thermally permissible rated torque.

The characteristics are limited by the respective maximum permissible speed  $n_{max}$  (for  $n_{max}$  refer to the "Technical data" table).

3

#### LST-190-1-30-560

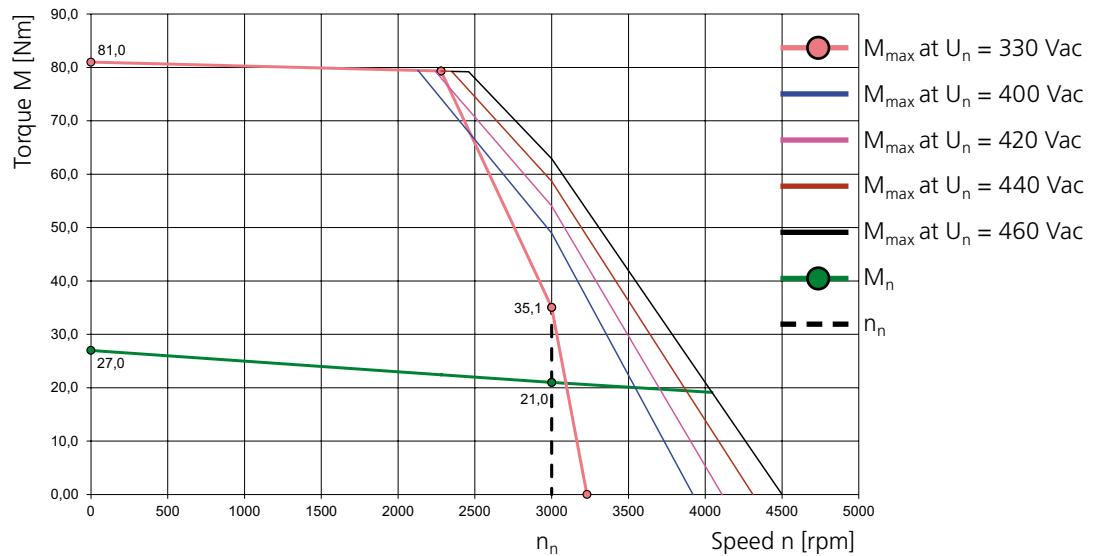

#### LST-190-2-30-560

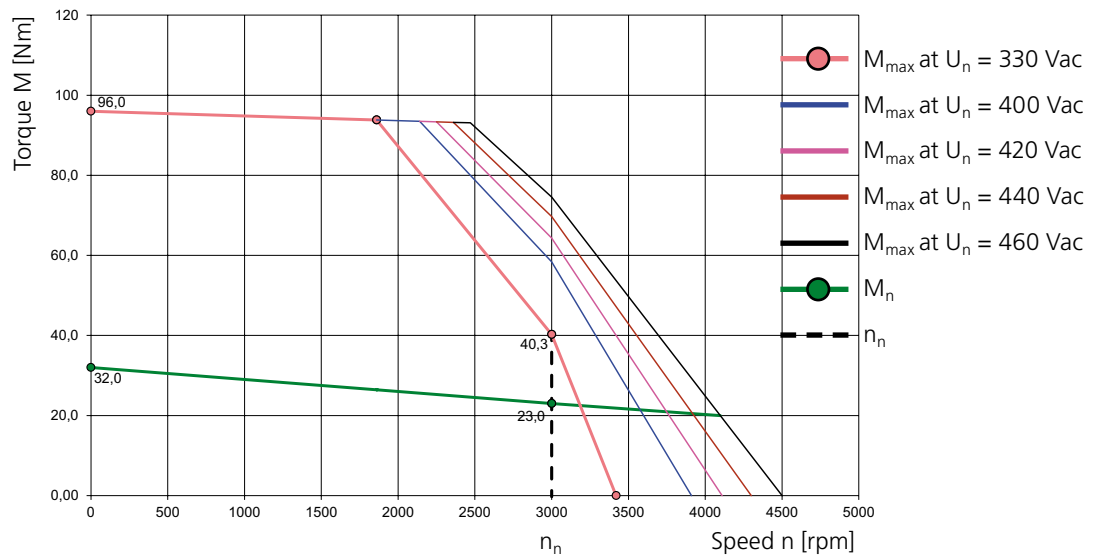

# LST-190-3-30-560

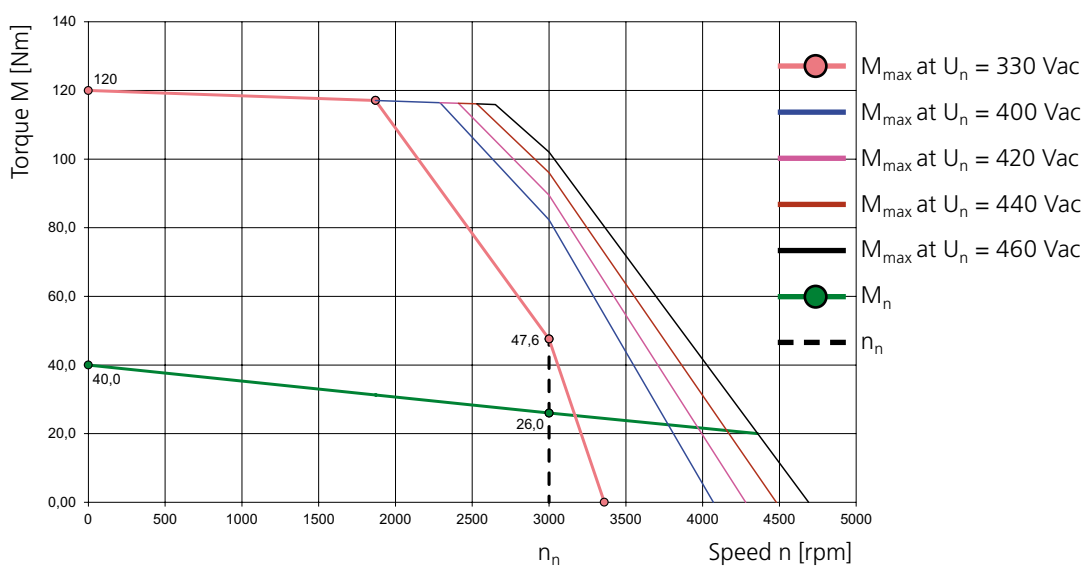

### 3.25 Motor type: LST-220 ( $U_{dc} = 560\text{ V}$ )

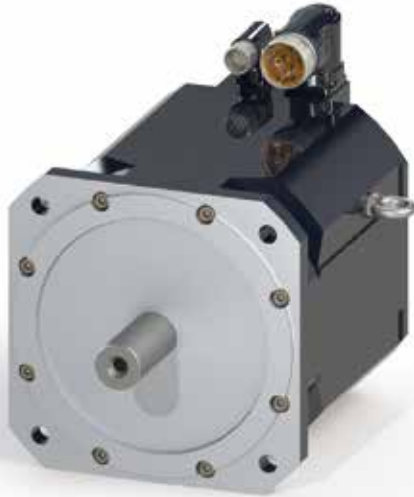

#### 3.25.1 Dimensional sketch and technical data

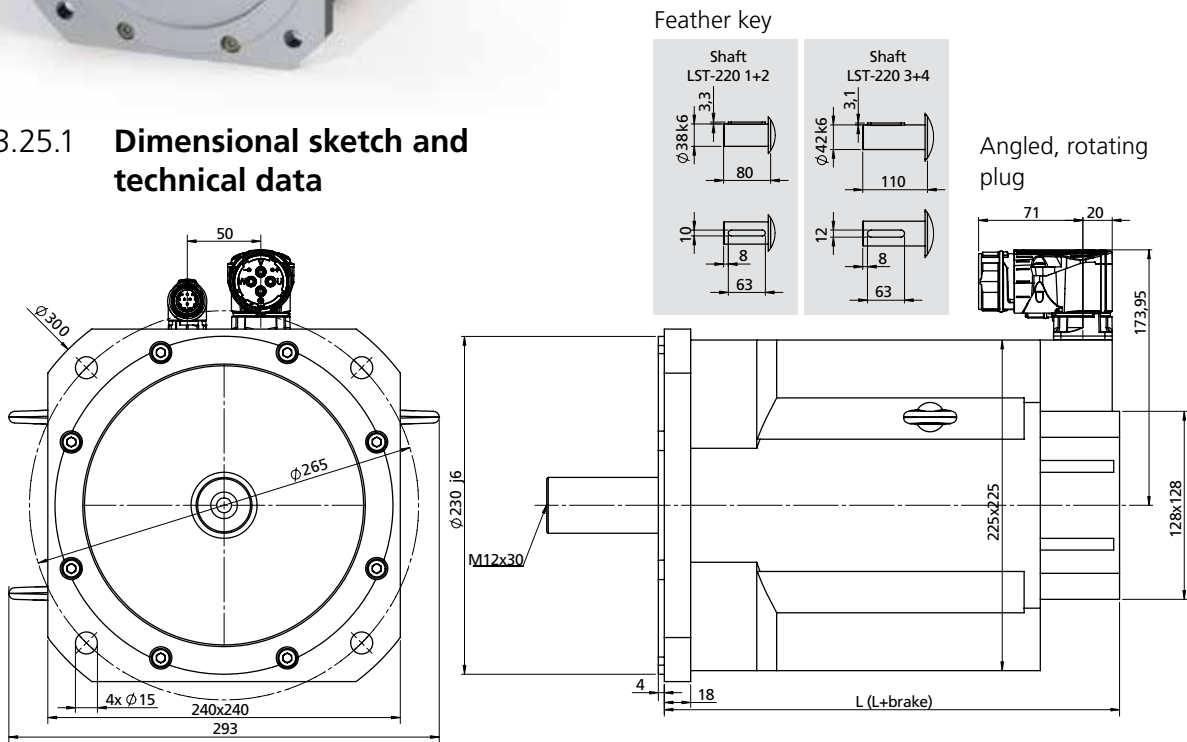

Motor type	L with resolver xR [mm]	L+brake with resolver xR [mm]	L with opt. encoder G12.xy [mm]	L+brake with opt. encoder G12.xy [mm]	L with opt. encoder G6.1x [mm]	L+brake with opt. encoder G6.1x [mm]
LST-220-1	310	378	322	390	312	381
LST-220-2	378	446	390	458	380	449
LST-220-3	446	514	458	526	448	517
LST-220-4	514	582	526	594	516	585

Motor type	L with opt. encoder G6.2x [mm]	L+brake with opt. encoder G6.2x [mm]	L with opt. encoder G6.3x [mm]	L+brake with opt. encoder G6.3x [mm]	L with opt. encoder G3/G5 [mm]	L+brake with opt. encoder G3/G5 [mm]
LST-220-1	In preparation	378	In preparation	In preparation	In preparation	In preparation
LST-220-2	In preparation	446	In preparation	In preparation	In preparation	In preparation
LST-220-3	In preparation	514	In preparation	In preparation	In preparation	In preparation
LST-220-4	In preparation	582	In preparation	In preparation	In preparation	In preparation

Table: Overview of motor lengths – for overview of encoder types see section 5.1



Technical data <sup>1)</sup>	Symbol	LST-220-1-30-560	LST-220-2-30-560	LST-220-3-30-560	LST-220-4-30-560
Rated speed	$n_n$	3000 rpm	3000 rpm	3000 rpm	3000 rpm
Rated frequency	$f_N$	150 Hz	150 Hz	150 Hz	150 Hz
DC link voltage (controller)	$U_{dc}$	560 V	560 V	560 V	560 V
Rated voltage	$U_n$	355 V	330 V	350 V	350 V
Rated torque	$M_n$	30 Nm	50 Nm	60 Nm	50 Nm
Rated current	$I_n$	17.8 A	31.1 A	34.9 A	29.3 A
Rated power	$P$	9.42 kW	15.7 kW	18.84 kW	15.7 kW
Stall torque	$M_0$	40 Nm	68 Nm	93 Nm	115 Nm
Stall current	$I_0$	21.8 A	39.9 A	53 A	63 A
Maximum permissible torque	$M_{max}$	120 Nm	204 Nm	279 Nm	345 Nm
Maximum permissible current	$I_{max}$	85 A	156 A	207 A	247 A
Maximum permissible speed	$n_{max}$	3600 rpm	3600 rpm	3600 rpm	3600 rpm
Voltage constant	$K_E$	111.0 V/1000 rpm	103.0 V/1000 rpm	106 V/1000 rpm	110.0 V/1000 rpm
Torque constant	$K_T$	1.84 Nm/A	1.7 Nm/A	1.75 Nm/A	1.82 Nm/A
Winding resistance (2 phases)	$R_{2ph}$	0.25 $\Omega$	0.10 $\Omega$	0.06 $\Omega$	0.05 $\Omega$
Winding inductance (2 phases)	$L_{2ph}$	5.7 mH	2.5 mH	1.88 mH	1.5 mH
No load speed	$n_0$	3190 rpm	3200 rpm	3300 rpm	3180 rpm
Electrical time constant	$T_{el}$	23 ms	25 ms	31 ms	30 ms
Thermal time constant	$T_{th}$	47 min.	65 min.	79 min.	90 min.
Moment of inertia of the motor	$J$	0.0076 kgm <sup>2</sup>	0.0114 kgm <sup>2</sup>	0.0153 kgm <sup>2</sup>	0.0190 kgm <sup>2</sup>
Mass	$m$	41 kg	56 kg	73 kg	89 kg

### Brake (optional)

Rated voltage	$U_N$	24 V $\pm$ 10 %
Rated current at 20 °C for venting	$I_N$	2.1 A
Permissible maximum speed	$n_{max}$	10000 rpm
Permissible friction energy	$W_R$	13 x 10 <sup>6</sup> Ws
Mass moment of inertia	$J_B$	0.0056 kgm <sup>2</sup>
Mass	$m$	9.5 kg
Braking torque	$M_H$	145 Nm

<sup>1)</sup> All values with a tolerance of  $\pm$  10%.

### 3.25.2 Characteristics

Explanations of characteristics:

The characteristic  $M_{max}$  describes the maximum possible short-time torque at corresponding speed. It is important for dynamic processes.

The characteristic  $M_n$  indicates the thermally permissible rated torque.

The characteristics are limited by the respective maximum permissible speed  $n_{max}$  (for  $n_{max}$  refer to the "Technical data" table).

3

#### LST-220-1-30-560

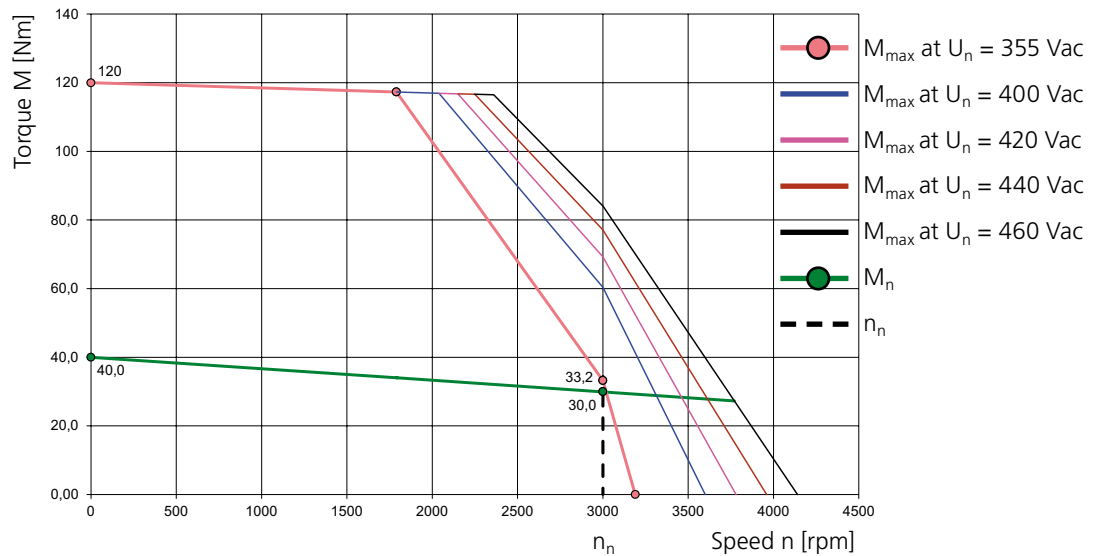

#### LST-220-2-30-560

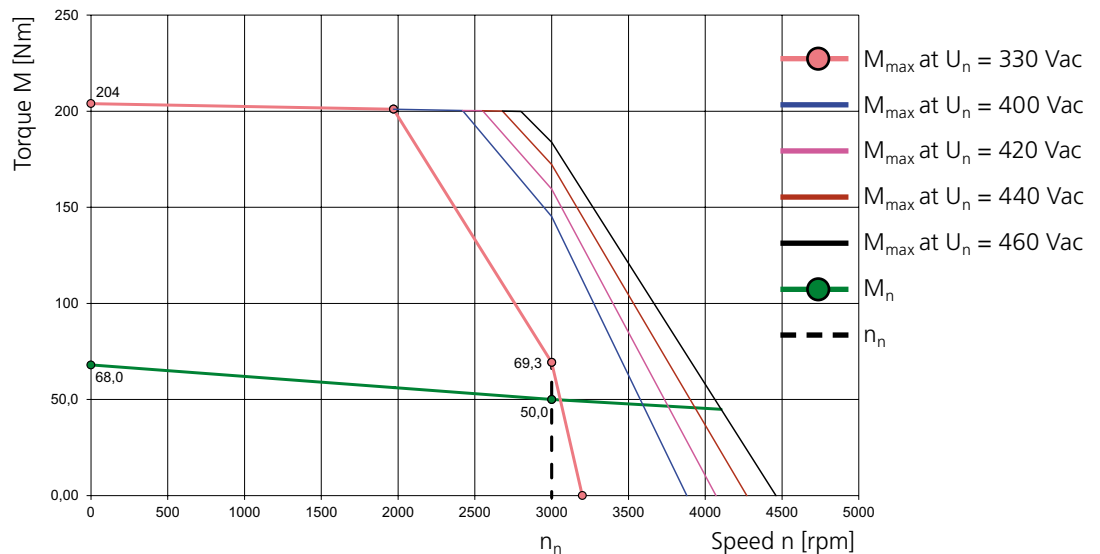

### LST-220-3-30-560

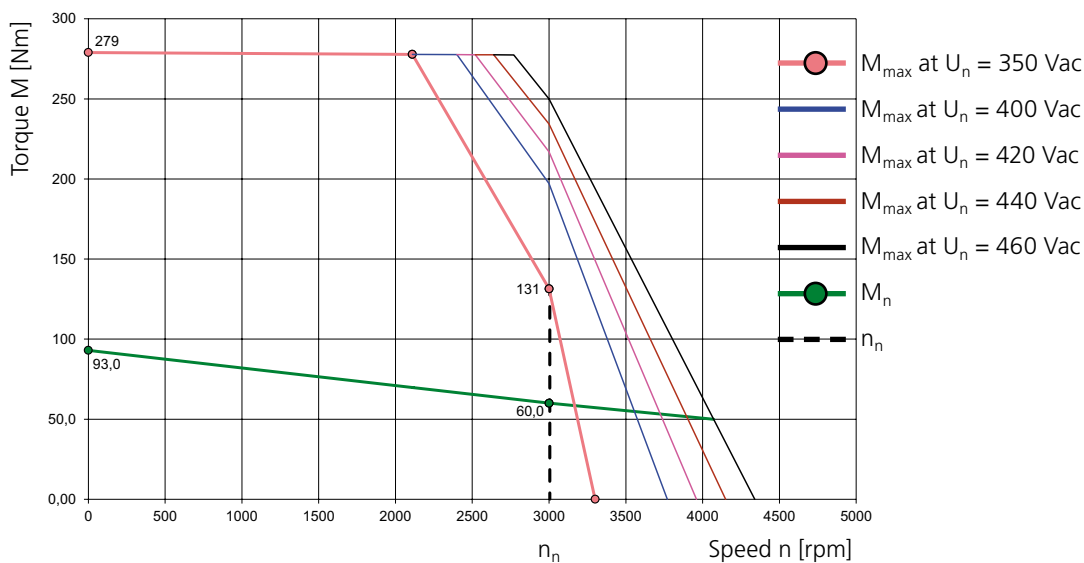

### LST-220-4-30-560

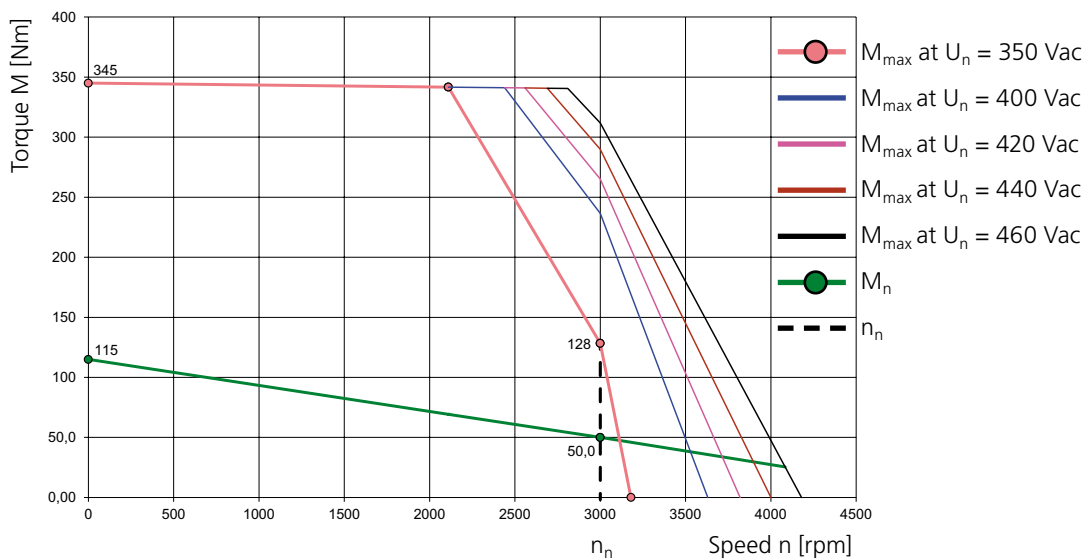



### 3.26 LST servomotors for functional extra-low voltage (24 V/48 V windings)



The servomotors of the LST series are also available with motor windings for functional extra-low voltage to IEC 364 (VDE0100, part 410). Together with the servocontroller CDF3000, they offer the optimum combination for this voltage range. LST servomotors can optionally be run with 24 V or 48 V DC link voltage.

#### Technical data

Motor type	Stall torque $M_0$ [Nm]	Rated torque $M_n$ [Nm]	Rated current at 24 V $I_n$ [A]	Rated current at 48 V $I_n$ [A]	Rated speed $n_n$ [rpm] at 24 V	Rated speed $n_n$ [rpm] at 48 V
LST-037-1-80-24/48	0.10	0.09	5.4	5.4	8000	8000
LST-037-2-60-24/48	0.20	0.18	6.9	6.9	6000	6000

Table: Technical data of the LST servomotor series for functional extra-low voltage – all values with a tolerance of  $\pm 5\%$

3.27 Motor type:  
LST-037  
( $U_{dc} = 24\text{ V}/48\text{ V}$ )



3.27.1 Dimensional sketch and technical data

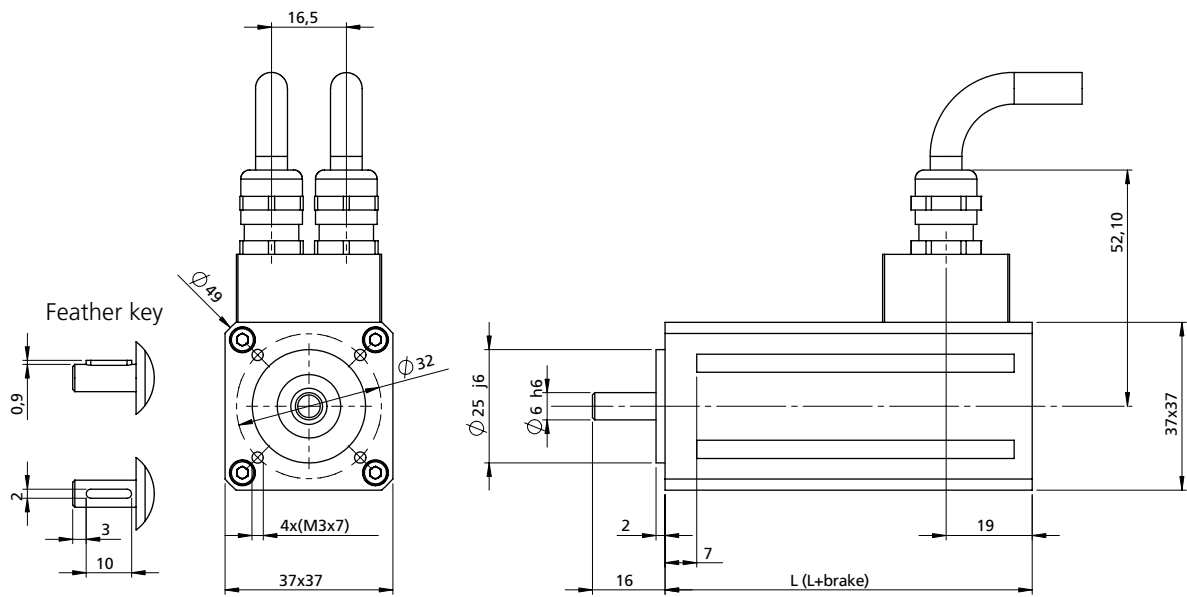

LST servomotors can optionally be run with 24 V or 48 V DC link voltage.

Motor type	L with resolver xR [mm]	L+brake with resolver xR [mm]
LST-037-1-80-24/48	81	111
LST-037-2-60-24/48	86	116

Table: Overview of motor lengths

Technical data <sup>1)</sup>	Symbol	LST-037-1-80-24/48		LST-037-2-60-24/48	
		at $U_{dc} = 24\text{ V}$	at $U_{dc} = 48\text{ V}$	at $U_{dc} = 24\text{ V}$	at $U_{dc} = 48\text{ V}$
Rated speed	$n_n$	8000 rpm	8000 rpm	6000 rpm	6000 rpm
Rated frequency	$f_N$	400 Hz	400 Hz	300 Hz	300 Hz
DC link voltage (controller)	$U_{dc}$	24 V	48 V	24 V	48 V
Rated voltage	$U_n$	15 V	30 V	15 V	30 V
Rated torque	$M_n$	0.09 Nm	0.09 Nm	0.18 Nm	0.18 Nm
Rated current	$I_n$	5.4 A	5.4 A	6.9 A	6.9 A
Rated power	P	0.075 kW	0.075 kW	0.11 kW	0.11 kW
Stall torque	$M_0$	0.10 Nm	0.10 Nm	0.20 Nm	0.20 Nm
Stall current	$I_0$	5.5 A	5.5 A	7.1 A	7.1 A
Maximum permissible torque	$M_{max}$	0.40 Nm	0.40 Nm	0.80 Nm	0.80 Nm
Maximum permissible current	$I_{max}$	24 A	24 A	31 A	31 A
Maximum permissible speed	$n_{max}$	12000 rpm	12000 rpm	12000 rpm	12000 rpm
Voltage constant	$K_E$	1.1 V/1000 rpm	1.1 V/1000 rpm	1.7 V/1000 rpm	1.7 V/1000 rpm
Torque constant	$K_T$	0.02 Nm/A	0.02 Nm/A	0.03 Nm/A	0.03 Nm/A
Winding resistance (2 phases)	$R_{2ph}$	0.42 $\Omega$	0.42 $\Omega$	0.34 $\Omega$	0.34 $\Omega$
Winding inductance (2 phases)	$L_{2ph}$	0.10 mH	0.10 mH	0.10 mH	0.10 mH
No load speed	$n_0$	13640 rpm	27520 rpm	8820 rpm	17700 rpm
Electrical time constant	$T_{el}$	0.24 ms	0.24 ms	0.29 ms	0.29 ms
Thermal time constant	$T_{th}$	18 min.	18 min.	20 min.	20 min.
Moment of inertia of the motor	J	0.000006 kgm <sup>2</sup>	0.000006 kgm <sup>2</sup>	0.000006 kgm <sup>2</sup>	0.000006 kgm <sup>2</sup>
Mass	m	0.37 kg	0.37 kg	0.45 kg	0.45 kg

### Brake (optional)

Rated voltage	$U_N$	24 V $\pm$ 10 %
Rated current at 20 °C for venting	$I_N$	0.33 A
Permissible maximum speed	$n_{max}$	10000 rpm
Permissible friction energy	$W_R$	0.20 x 10 <sup>6</sup> Ws
Mass moment of inertia	$J_B$	0.000013 kgm <sup>2</sup>
Mass	m	0.075 kg
Braking torque	$M_H$	0.4 Nm

1) All values with a tolerance of  $\pm$  10%.

### 3.27.2 Characteristics

Explanations of characteristics:

The characteristic  $M_{max}$  describes the maximum possible short-time torque at corresponding speed. It is important for dynamic processes.

The characteristic  $M_n$  indicates the thermally permissible rated torque.

The characteristics are limited by the respective maximum permissible speed  $n_{max}$  (for  $n_{max}$  refer to the "Technical data" table).



**NOTE:** LST servomotors for functional extra-low voltage can optionally be run with 24 V or 48 V DC link voltage.

3

#### LST-037-1-80-24

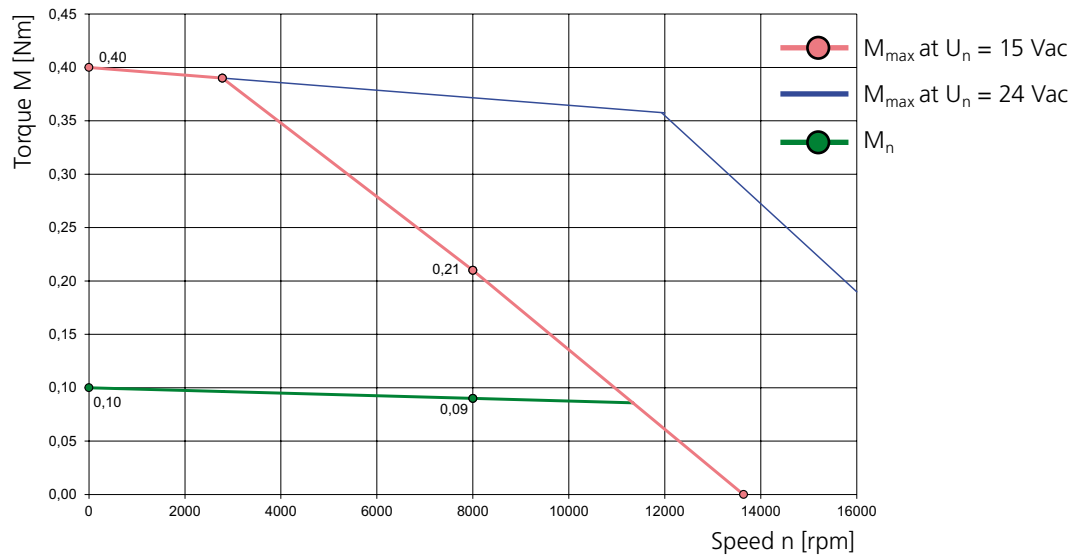

#### LST-037-2-60-24

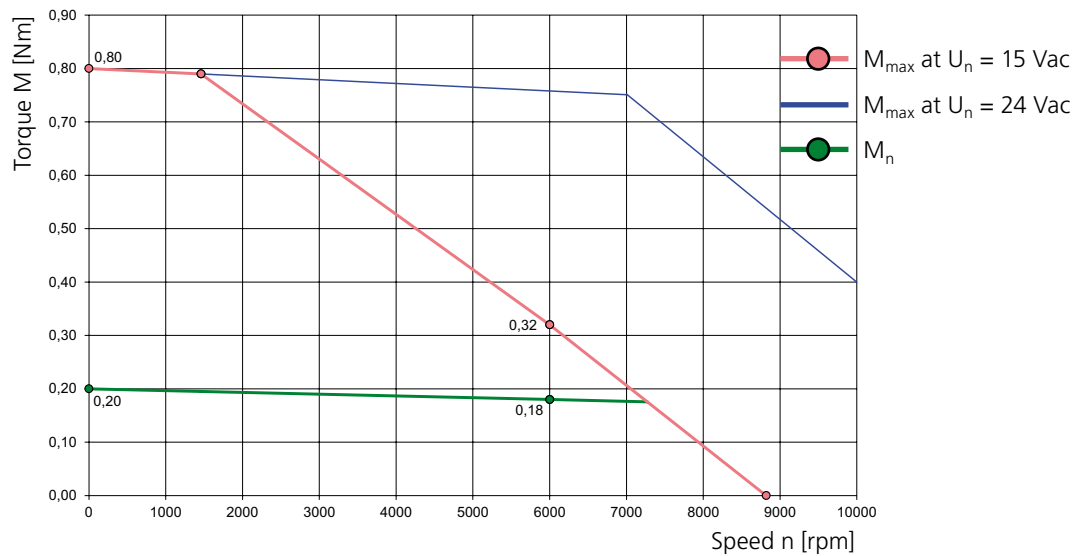

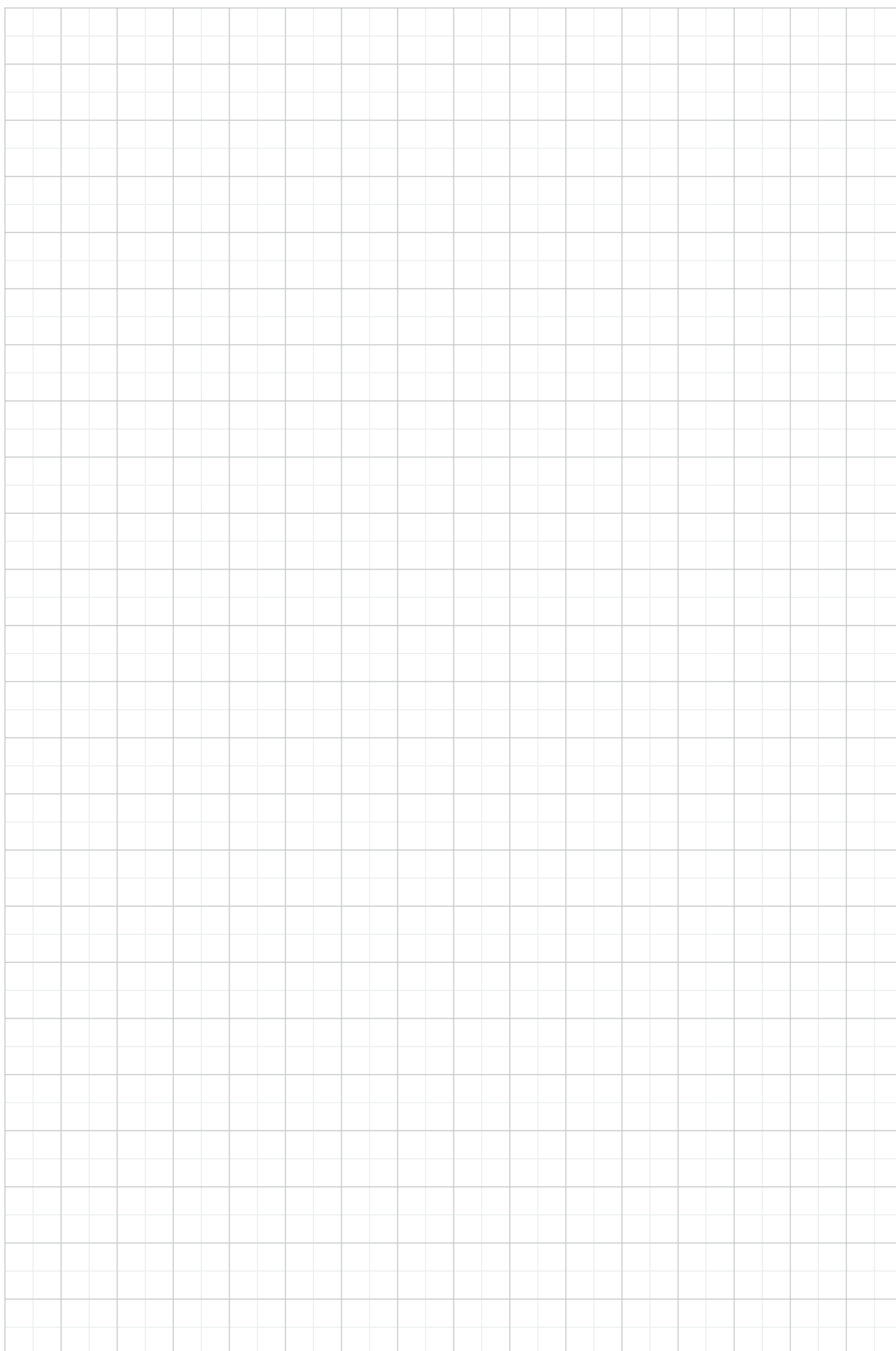

Space for notes

A large, empty grid of small squares, intended for taking notes. The grid is composed of 20 columns and 30 rows of squares.

Space for notes

A large grid of graph paper for taking notes, consisting of 20 columns and 30 rows of small squares.



## 4 The LSH servomotor – the power pack

### 4.1 Applications

LTI synchronous servomotors are brushless three-phase-current motors for high-end servo applications, available in all speed and voltage variants. They are particularly suitable for positioning tasks on machine tools, industrial robots, transfer lines, etc., as well as for applications entailing high dynamic and stability demands.

The standard versions of our servomotors are equipped to handle a wide range of applications. Available options include a holding brake, IP65 protection, a wide variety of temperature monitors, cable tails, high-resolution SSI encoders and Hiperface encoder, through to custom flanges and special shafts. We also optionally offer our servomotors in EX (explosion-proof) variants. Contact our drive specialists for details.

Because of its "concentrated winding" technique (also known as "pole winding"), the LSH series in the rated torque range ( $M_0$ ) from 0.2 Nm to 27 Nm (externally cooled up to 35 Nm) improves power density between 30% and 70% compared to conventional (distributed) winding technology.

For the user this means up 100% improvement in dynamism and significantly reduced space requirements combined with smooth running.

### 4.2 Features of LSH servomotors

- Increased dynamism
- Less space requirement
- Good smooth-running behaviour
- Well suited to low-voltage windings
- High availability of special windings

## 4.3 Declaration of conformity for LSH servomotors

### EG-Konformitätserklärung



#### EC Declaration of Conformity

Der Hersteller  
*The manufacturer* LTi DRIVES GmbH  
Gewerbestraße 5-9  
35633 Lahnau

erklärt hiermit, dass die folgenden Produkte  
*declares that the following products*

Produktbezeichnung:  
*Product designation:* Synchron-Servomotor  
*Synchronous Servomotor*

Produkttypen:  
*Product types:* LSH, LST, LSN  
*LSH, LST, LSN*

den Sicherheitsbestimmungen der nachstehenden EG-Richtlinie entsprechen:  
*comply with the essential requirements of the following EC Directive:*

2006/95/EG  
*2006/95/EC* [Niederspannungsrichtlinie]  
*[Low Voltage Directive]*

und dass folgende angeführte harmonisierte Norm angewandt wurde:  
*and that the following harmonised standard has been applied:*

EN 60034-1:2004  
Drehende elektrische Maschinen - Teil 1: Bemessung und Betriebsverhalten (IEC 60034-1:2004)  
*Rotating electrical machines - Part 1: Rating and performance (IEC 60034-1:2004)*

EN 60034-5:2001+A1:2007  
Drehende elektrische Maschinen - Teil 5: Schutzarten aufgrund der Gesamtkonstruktion von drehenden elektrischen Maschinen (IP-Code) - Einteilung (IEC 60034-5:2000)  
*Rotating electrical machines - Part 5: Degrees of protection provided by the integral design of rotating electrical machines (IP code); Classification (IEC 60034-5:2000)*

EN 60034-6:1993  
Drehende elektrische Maschinen - Teil 6: Einteilung der Kühlverfahren (IC-Code) (IEC 60034-6:1991)  
*Rotating electrical machines - Part 6: Methods of cooling (IC-Code) (IEC 60034-6:1991)*

EN 60034-9:2005+A1:2007  
Drehende elektrische Maschinen - Teil 9: Geräuschgrenzwerte (IEC 60034-9:2003)  
*Rotating electrical machines - Part 9: Noise limits (IEC 60034-9:2003)*

Jahr der CE-Kennzeichnung / *Year of CE-marking:* 2005

Unterschrift / *signature*

Name / *name:*

Stellung / *position:*

Datum / *date:*

  
Dr. Josef Wiesing

Geschäftsführer / *Managing Director*

04.12.2012

Dokument: 0970.0DK.2-04

## 4.4 Properties of LSH servomotors

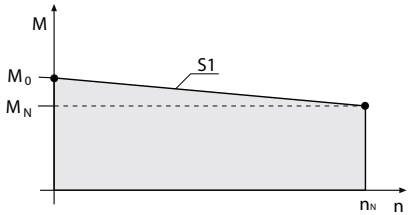
Machine type	Permanently excited 3-phase-current synchronous servomotor
Magnet material	Neodymium-iron-boron
Design (DIN 42948)	B5, V1, V3
Protection (DIN 40050)	IP64, IP54 to EN 60034-5 (circulating machines), IP65 optionally available
Insulating material class	Insulating material class F to VDE0530 , winding overtemperature $\Delta t = 100\text{ }^\circ\text{C}$ , ambient temperature $t_u = -20\text{ }^\circ\text{C}$ to $+40\text{ }^\circ\text{C}$ , no condensation!!!
Coating	RAL 9005 (matt black)
Shaft end on A-side	Smooth shaft (feather key and feather key way DIN 6885, tolerance band k6 as option)
Smooth running, coaxiality and axial run-out to DIN 42955	Tolerance N (normal), tolerance R (reduced) on request
Thermal motor monitoring	DIN-PTC in a stator winding
Torque load	To prevent thermal motor overloading, the effective load moment at medium RPM must not be above curve S1.
	
$M_{\text{eff}} = \sqrt{\frac{S (M_n^2 \times t_n)}{t_{\text{ges}}}} \quad \bar{n} = \frac{S (n_n \times t_n)}{t_{\text{ges}}}$	
Maximum pulse torque	Typically 2 to 4 times rated torque for max. 0.2 s, depending on controller assignment
Vibration severity to ISO 2373	Grade N, optionally R
Bearing service life	The average service life under nominal conditions ( $M_{\text{max}} \leq M_N$ ) is 20,000 h
Termination mode of motor, thermistor and holding brake	via plug-in terminals
Termination mode of encoder system	Signal plug (mating plug not supplied)

## 4.5 Cooling

The specified nominal data relate to a maximum ambient temperature of  $40\text{ }^\circ\text{C}$  and mounting of the motor on an aluminium plate with a maximum temperature of  $65\text{ }^\circ\text{C}$  and installed at an altitude of max. 1,000 m above MSL.

Minimum mounting area: 2.5 x area of motor flange

Thickness of mounting area: min. 10 mm

If the motor is mounted with insulation (no heat discharge via the flange) the nominal torque must be reduced. For installations above an altitude of  $> 1000\text{ m}$  above MSL the power output must be reduced by 1 % per 100 metres. The maximum installation altitude is 4000 metres. At ambient temperatures  $> 40\text{ }^\circ\text{C}$  the power output must be reduced by 1 % per  $1^\circ\text{C}$ . The maximum ambient temperature is  $50\text{ }^\circ\text{C}$ .

## 4.6 Order codes for LTi LSH series synchronous motors



### NOTE:

Preferential types are motors and options readily available ex stock. The wide range of variants means there are many combination options. The options marked with "\*" are preferential types and can be delivered more quickly.

Options (if available, sequence varying)	
<b>LSH-074-1-30-560/ D1 , B , P , X , K , S4 , G6.1S , W</b>	
<b>LTi synchronous motor series H</b>	
<b>Edge dimensions in mm (no flange dimensions)</b>	<b>050 074 097 127</b>
<b>Length</b> (1... shortest motor type, 5... longest motor type) Dependent on the selected encoder.	<b>1 2 3 4</b>
<b>Rated speed (x100) in rpm</b>	<b>15 30 20 45</b>
<b>DC link voltage of controller (VDC)</b>	<b>24 48 320 560</b>
<b>Options Thermal protection</b>	Thermoswitch / e.g. Klixon → <b>T0</b> (DIN-PTC double basic insulation) → <b>*T1</b> <b>Standard!</b> KTY84-130 → <b>T4</b>
<b>Brake option</b>	Holding brake 24 VDC <b>*B</b>
<b>Feather key option</b>	Feather key to DIN 6885, Sheet 1 <b>*P</b>
<b>Custom variant</b>	(e.g. special flange/shaft/housing/encoder, etc.) <b>X</b>
<b>Cable option</b>	Cable, 1 m, open ends <b>K</b>
<b>Termination option</b> (The A-side of the motor is the shaft face)	Angled plug, aligned to A-side <b>S1</b> Angled plug, aligned to B-side <b>S2</b> Angled plug, rotated 90° <b>S3</b> Angled/rotating plugs <b>*S4</b> from size LSN-127, angled, rotating plugs with raised body, rotation angle 270° <b>S7</b>
<b>Options Encoder system</b> (For details see following table)	Resolver with 1 pole pair → <b>*1R</b> Resolver with 1 pole pair Safety → <b>1RY</b> Resolver with 3 pole pair → <b>3R</b> Resolver with 5 pole pair → <b>5R</b> Multi-turn absolute value encoder EQN 1325 → <b>G3</b> Single-turn absolute value encoder ECN 1313 → <b>G5</b> Single-turn absolute value encoder SRS 50 → <b>G6.1S</b> Multi-turn absolute value encoder SRM 50 → <b>G6.1M</b> Single-turn absolute value encoder SKS 36 → <b>G6.2S</b> Single-turn absolute value encoder SKS 36 Safety → <b>G6.2SY</b> Multi-turn absolute value encoder SKM 36 → <b>G6.2M</b> Multi-turn absolute value encoder SKM 36 Safety → <b>G6.2MY</b> Single-turn absolute value encoder ECN 1313 → <b>G12.1S</b> Multi-turn absolute value encoder EQN 1325 → <b>G12.1M</b> Single-turn absolute value encoder ECN 1113 → <b>G12.2S</b> Multi-turn absolute value encoder EQN 1125 → <b>G12.2M</b>
<b>Options Shaft packing ring</b>	Protection IP65 with shaft packing ring (approx.10mm longer) → <b>W</b> Protection IP65 without shaft packing ring → <b>V</b>

Table: Order codes for LSH servomotors.

The options marked with "\*" are preferential types and can be delivered more quickly.



## 4.10 Encoder system options



### NOTE:

Preferential types are motors and options readily available ex stock. The wide range of variants means there are many combination options. The options marked with "\*" are preferential types and can be delivered more quickly.

Ordering options	Description	Interface	Oscillations analog	Multi-turn resolution	Compatible with
*1R	Resolver with 1 pole pair	Analog	1	-	<b>all LSH</b>
1RY	Resolver with 1 pole pair Safety	Analog	1	-	<b>all LSH <sup>1)</sup></b>
3R	Resolver with 3 pole pair	Analog	3	-	<b>only LSH-050</b>
5R	Resolver with 5 pole pair	Analog	5	-	<b>from LSH-074</b>
G3	Multi-turn absolute value encoder EQN 1325	Analog and SSI	2048	12-bit	<b>from LSH-074</b>
G5	Single-turn absolute value encoder ECN 1313	Analog and SSI	2048	-	<b>from LSH-074</b>
G6.1S	Single-turn absolute value encoder SRS 50	Analog and Hiperface	1024	-	<b>from LSH-074</b>
G6.1M	Multi-turn absolute value encoder SRM 50	Analog and Hiperface	1024	12-bit	<b>from LSH-074</b>
G6.2S	Single-turn absolute value encoder SKS 36	Analog and Hiperface	128	-	<b>all LSH</b>
G6.2SY	Single-turn absolute value encoder SKS 36 Safety	Analog and Hiperface	128	-	<b>all LSH <sup>1)</sup> (ServoOne safety)</b>
G6.2M	Multi-turn absolute value encoder SKM 36	Analog and Hiperface	128	12-bit	<b>all LSH</b>
G6.2MY	Multi-turn absolute value encoder SKM 36 Safety	Analog and Hiperface	128	12-bit	<b>all LSH <sup>1)</sup> (ServoOne safety)</b>
G12.1S	Single-turn absolute value encoder ECN 1313	Analog and Endat 2.1	2048	-	<b>from LSH-074</b>
G12.1M	Multi-turn absolute value encoder EQN 1325	Analog and Endat 2.1	2048	12-bit	<b>from LSH-074</b>
G12.2S	Single-turn absolute value encoder ECN 1113	Analog and Endat 2.1	512	-	<b>only LSH-050</b>
G12.2M	Multi-turn absolute value encoder EQN 1125	Analog and Endat 2.1	512	12-bit	<b>only LSH-050</b>

Table: Explanation of encoder systems

1) Suitable for safety applications to EN 62061 and IEC 61508 and to EN ISO 13849-1

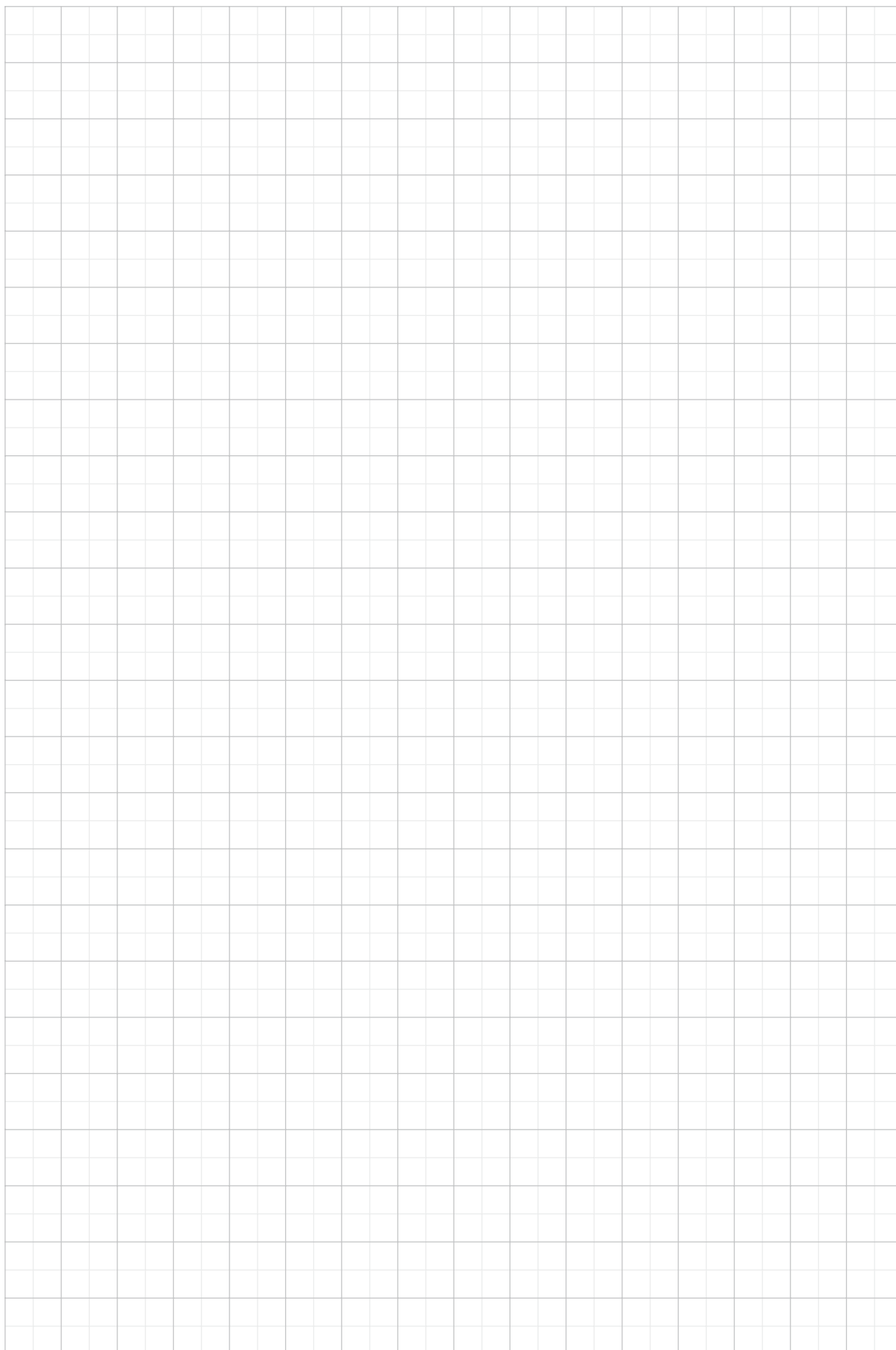

Space for notes

A large, empty grid of small squares, intended for taking notes. The grid is composed of 20 columns and 30 rows of squares.

## 4.11 Typical M-n characteristic of LSH servomotors

The characteristic indicates how the servomotor's speed responds to increasing load.

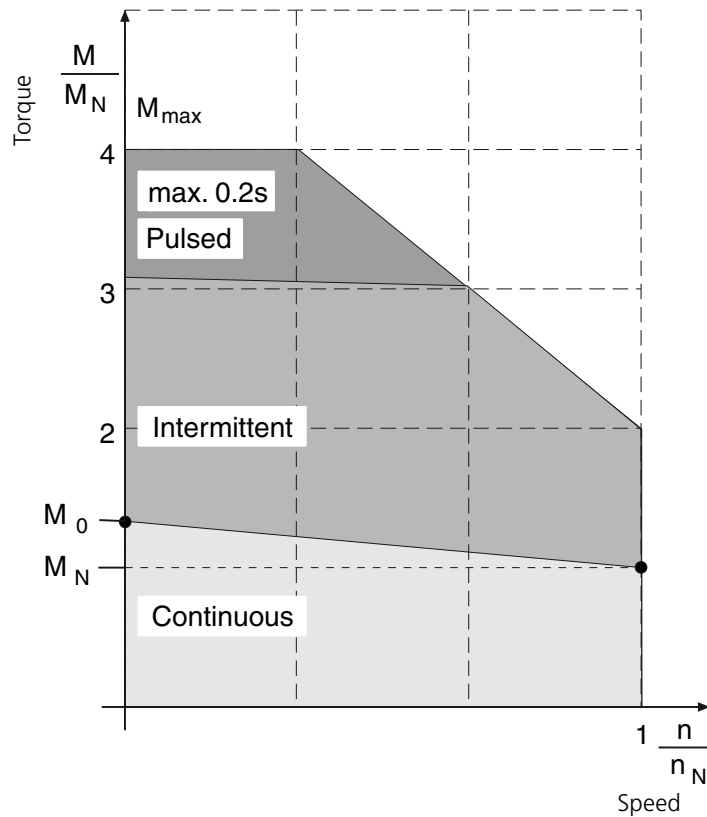

4

### M-n characteristic for synchronous motors

Term	Explanation
$n_N$ Rated speed	Speed at which a motor outputs the highest possible power (rated power) under full load.
$M_0$ Stall torque	Thermal limit torque of the motor at standstill. The motor can deliver this torque for an unlimited length of time.
$I_0$ Stall current	Effective value of the motor phase current required to generate the stall torque.
$M_n$ Rated torque	Thermal limit torque of the motor at rated speed $n_N$ .
$I_N$ Rated current	R.m.s. value of the motor phase current required to generate the nominal torque.
$P_N$ Rated power	Continuous power output of the motor at the nominal operation point ( $M_N, n_N$ ) at rated current $I_N$ and rated voltage $U_N$ .
$M_{MAX}, I_{MAX}$ Limit characteristic	A maximum of four times the rated current may be applied to the motors.

Table: Definition: M-n characteristic for synchronous motors

## 4.12 Permissible axial and lateral forces of LSH servomotors

Sizes	Radial force $F_{Rm}$ [N] at speed $n$ [rpm]					Axial force $F_{Am}$ [N] at speed $n$ [rpm]					$F_G$ [N]
	1000	2000	3000	4500	6000	1000	2000	3000	4500	6000	
LSH-050	310	250	220	190	170	60	50	42	36	32	2
LSH-074	480	380	330	290	260	90	70	63	55	50	6
LSH-097	850	680	600	520	470	160	130	115	100	90	15
LSH-127	970	770	670	590	530	185	145	125	110	100	34

Table: Permissible axial and lateral forces of LSH servomotors.  $F_G$  ... Force due to weight of rotor.

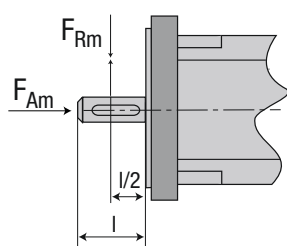

The table indicates the max. permissible lateral force  $F_{Rm}$  at the point of application  $l/2$  and the maximum permissible axial force  $F_{Am}$  for a service life of 20,000 h. A lateral force not applied in the middle of the shaft end can simply be translated to allow for the changed lever ratios.

Either the permissible radial force or the axial force may act on the motor shaft!

### Technical data – design

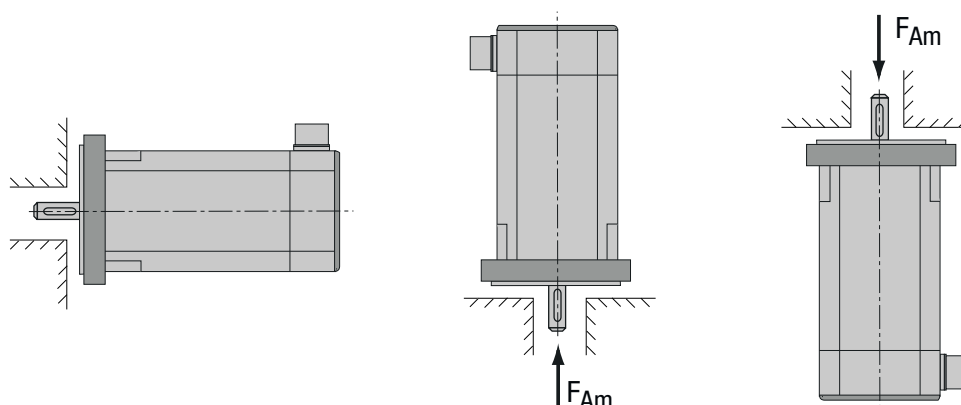

Design	B5	V1	V3
Shaft	Free shaft end	Free shaft end at bottom	Free shaft end at top
Attachment	Flange mounting Access from housing side	Flange mounting at bottom Access from housing side	Flange mounting at top Access from housing side



**NOTE:** With vertical mounting (V1) the permissible axial forces ( $F_{A\Delta}$ ) apply. With vertical upward mounting (V3) the permissible axial forces are reduced by the force due to weight of the rotor ( $F_G$ ).

## 4.13 Connections



LSH-074-1-30-560/S4\*, G3\*

Plug alignment

Plug configuration

\*Example

Standard version

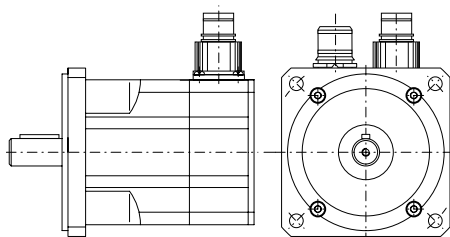

Straight plug

Version S4

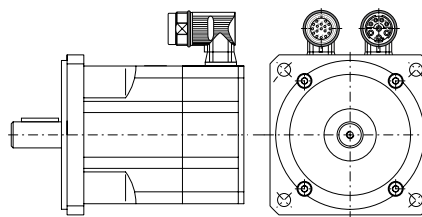

Angled/rotating plug

Version S7



Angled plug rotating 270°

As from size LSN-127, raised bodies are used for angled, rotating plugs with a rotation angle of 270°.

## Encoder connections

### Encoder connection xR (resolver)

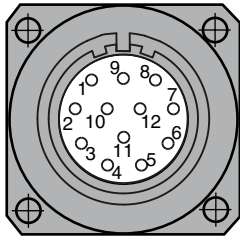

12-pin socket Junction box  
Contact pins Ø 1 mm

Pin	term	term
1	Cos +	(S1)
2	COS-	(S3)
3	SIN+	(S2)
4	SIN-	(S4)
6	REF+	(R1)
7	REF-	(R2)
11	PTC+	Motor PTC
12	PTC-	Motor PTC
5, 8, 9, 10	n. c.	Not used

Table: Encoder connection xR (resolver)

### Encoder connection Gx (optical encoder)

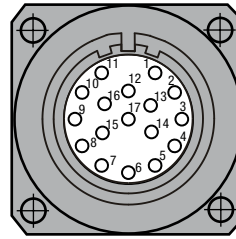

17-pin socket Junction box  
Contact pins Ø 1 mm

Pin	term G3, G5, G12.x	term G6.x
1	A+	A+
2	A-	A-
3	B+	B+
4	B -	B -
7	GND / 0V	GND / 0V
8	VCC +5 V/150 mA	-
9	-	VCC 7-12V/100mA
10	DATA+	DATA+
11	DATA-	DATA-
12	CLK+	-
13	CLK-	-
16	VCC-Sense	-
17	GND-Sense	-
5, 6, 14, 15	n. c.	n. c.

Table: Encoder connection Gx (optical encoder)

## Power connections

### Power connection

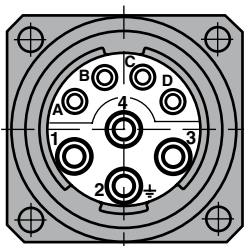

8-pin socket Junction box  
Contact pins  
for contact 1 ... 4 Ø 2 mm  
for contact A ... D Ø 1 mm

Pin	Des.	Designation
1	U	Motor phase U
2	PE	PE
3	W	Motor phase W
4	V	Motor phase V
A	Brake +	Brake+
B	Brake -	Brake -
C	PTC+	Motor PTC <sup>1)</sup>
D	PTC-	Motor PTC <sup>1)</sup>

<sup>1)</sup> For motors with resolver, not assigned

Table: Power connection of LST servomotors

## 4.14 Key definitions

<b>Stall torque</b> <b><math>M_0</math> [Nm]</b>	The stall torque can be outputted for an unlimited time at speed $n=0$ rpm and under nominal ambient conditions.
<b>Rated torque <math>M_n</math> [Nm]</b>	The rated torque is outputted when the motor is drawing rated current at rated speed. The rated torque can be outputted for an unlimited time at rated speed in continuous operation.
<b>Stall current <math>I_0</math> [A]</b>	The stall current is the sine-effective current value which the motor draws at standstill in order to output the stall torque.
<b>Rated current <math>I_n</math> [A]</b>	The rated current is the sine-effective current value which the motor draws at rated speed in order to output the rated torque.
<b>Maximum permissible current (peak current) <math>I_{max}</math> [A]</b>	The peak current (sine-effective value) should not be more than 4 times the rated current. The actual value is determined by the peak current of the inverter being used.
<b>Torque constant</b> <b><math>K_T</math> [Nm/A]</b>	The torque constant indicates how much torque in Nm the motor generates with 1A sine-effective current. The equation is $M=I \times K_T$
<b>Voltage constant <math>K_E</math> [V/1000 rpm]</b>	The voltage constant indicates the induced motor EMF as a sine peak value between two terminals, referred to 1000 rpm.
<b>Moment of inertia of rotor <math>J</math> [kgcm<sup>2</sup>]</b>	The constant $J$ is a measure of the mass inertia of the motor.
<b>Thermal time constant</b> <b><math>T_{th}</math> [min]</b>	The constant $T_{th}$ indicates the warm-up time of the cold motor under $I_0$ load until $0.63 \times 105$ Kelvin overtemperature is reached. Under peak current the warm-up time is much shorter.
<b>Rated speed <math>n_n</math> [rpm]</b>	The rated speed is the speed at which a servomotor outputs the highest possible power – the so-called rated power –under full load.

Table: Key definitions

## 4.15 Overview of LSH servomotors



### Technical data

Motor type	DC link voltage [V]	Stall torque $M_0$ [Nm]	Rated torque $M_n$ [Nm]	Rated current at 560 V $I_n$ [A]	Rated current at 320 V $I_n$ [A]	Rated speed $n_n$ [rpm]
LSH-050-1	320	0.26	0.24	-	0.68	4500
LSH-050-2	320	0.53	0.45	-	1.11	4500
LSH-050-3	320	0.74	0.67	-	1.55	4500
LSH-050-4	320	0.95	0.84	-	1.90	4500
LSH-074-1	320/560	0.95	0.86	1.28	1.43	3000
LSH-074-2	320/560	1.90	1.60	1.46	2.40	3000
LSH-074-3	320/560	3.30	2.90	2.30	4.00	3000
LSH-074-4	320/560	4.20	3.10	2.30	3.70	3000
LSH-097-1	320/560	4.10	3.20	2.80	5.00	3000
LSH-097-2	320/560	6.30	4.60	3.60	7.00	3000
LSH-097-3	320/560	8.60	6.10	4.80	8.3	3000
LSH-127-1	560	11.60	8.40	7.90	-	3000
LSH-127-2	560	14.90	10.90	9.60	-	3000
LSH-127-3	560	18.70	14.30	13.10	-	3000
LSH-127-4	560	27.30	21.00	14.90	-	3000

Table: Technical data of the LSH servomotor series - all values with a tolerance of  $\pm 5\%$

## 4.16 Motor type: LSH-050 ( $U_{dc} = 320\text{ V}$ )



### 4.16.1 Dimensional sketch and technical data

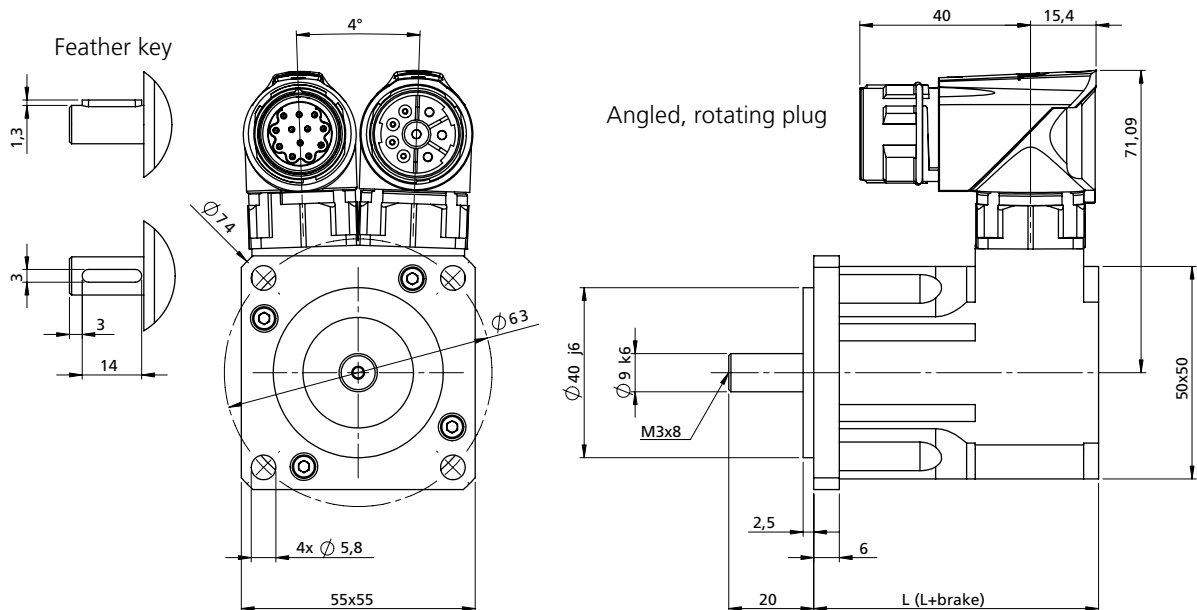

Motor type	L with resolver xR [mm]	L+brake with resolver xR [mm]	L with opt. encoder G12.xy [mm]	L+brake with opt. encoder G12.xy [mm]	L with opt. encoder G6.1x [mm]	L+brake with opt. encoder G6.1x [mm]
LSH-050-1	67	105	130.5	168.5	In preparation	In preparation
LSH-050-2	82	120	145.5	183.5	In preparation	In preparation
LSH-050-3	97	135	160.5	198.5	In preparation	In preparation
LSH-050-4	112	150	175.5	213.5	In preparation	In preparation

Motor type	L with opt. encoder G6.2x [mm]	L+brake with opt. encoder G6.2x [mm]	L with opt. encoder G6.3x [mm]	L+brake with opt. encoder G6.3x [mm]	L with opt. encoder G3/G5 [mm]	L+brake with opt. encoder G3/G5 [mm]
LSH-050-1	98	133	In preparation	In preparation	106.5	144.5
LSH-050-2	113	148	In preparation	In preparation	121.5	159.5
LSH-050-3	128	163	In preparation	In preparation	136.5	174.5
LSH-050-4	143	178	In preparation	In preparation	151.5	189.5

Table: Overview of motor lengths – for overview of encoder types see section 5.1



Technical data <sup>1)</sup>	Symbol	LSH-050-1-45-320	LSH-050-2-45-320	LST-050-3-45-320	LST-050-4-45-320
Rated speed	$n_n$	4500 rpm	4500 rpm	4500 rpm	4500 rpm
Rated frequency	$f_N$	225 Hz	225 Hz	225 Hz	225 Hz
DC link voltage (controller)	$U_{dc}$	320 V	320 V	320 V	320 V
Rated voltage	$U_n$	200 V	200 V	200 V	200 V
Rated torque	$M_n$	0.24 Nm	0.45 Nm	0.67 Nm	0.84 Nm
Rated current	$I_n$	0.68 A	1.11 A	1.55 A	1.90 A
Rated power	P	0.11 kW	0.21 kW	0.31 kW	0.40 kW
Stall torque	$M_0$	0.26 Nm	0.53 Nm	0.74 Nm	0.95 Nm
Stall current	$I_0$	0.70 A	1.26 A	1.66 A	2.1 A
Maximum permissible torque	$M_{max}$	1.0 Nm	2.0 Nm	2.8 Nm	3.6 Nm
Maximum permissible current	$I_{max}$	2.9 A	5.1 A	6.7 A	8.5 A
Maximum permissible speed	$n_{max}$	12000 rpm	12000 rpm	12000 rpm	12000 rpm
Voltage constant	$K_E$	22.5 V/1000 rpm	25.5 V/1000 rpm	27.0 V/1000 rpm	27.5 V/1000 rpm
Torque constant	$K_T$	0.37 Nm/A	0.42 Nm/A	0.45 Nm/A	0.45 Nm/A
Winding resistance (2 phases)	$R_{2ph}$	33.1 $\Omega$	16.4 $\Omega$	11.1 $\Omega$	8.4 $\Omega$
Winding inductance (2 phases)	$L_{2ph}$	51 mH	32.7 mH	24.5 mH	19.4 mH
No load speed	$n_0$	8890 rpm	7840 rpm	7410 rpm	7250 rpm
Electrical time constant	$T_{el}$	1.5 ms	2.0 ms	2.2 ms	2.3 ms
Thermal time constant	$T_{th}$	13 min.	15 min.	20 min.	22 min.
Moment of inertia of the motor	J	0.000006 kgm <sup>2</sup>	0.000008 kgm <sup>2</sup>	0.00001 kgm <sup>2</sup>	0.000012 kgm <sup>2</sup>
Mass	m	0.75 kg	0.92 kg	1.1 kg	1.26 kg

#### Brake (optional)

Rated voltage	$U_N$	24 V $\pm$ 10 %
Rated current at 20 °C for venting	$I_N$	0.46 A
Permissible maximum speed	$n_{max}$	10000 rpm
Permissible friction energy	$W_R$	0.41 x 10 <sup>6</sup> Ws
Mass moment of inertia	$J_B$	0.000007 kgm <sup>2</sup>
Mass	m	0.15 kg
Braking torque	$M_H$	2 Nm

<sup>1)</sup> All values with a tolerance of  $\pm$  10%.

## 4.16.2 Characteristics

Explanations of characteristics:

The characteristic  $M_{\max}$  describes the maximum possible short-time torque at corresponding speed. It is important for dynamic processes.

The characteristic  $M_n$  indicates the thermally permissible rated torque.

The characteristics are limited by the respective maximum permissible speed  $n_{\max}$  (for  $n_{\max}$  refer to the "Technical data" table).

### LSH-050-1-45-320

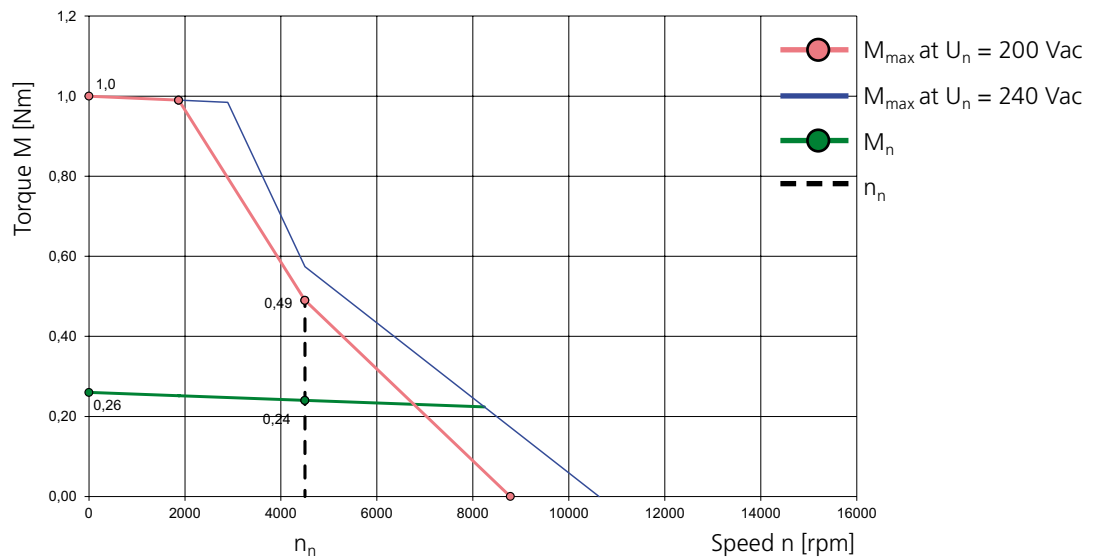

### LSH-050-2-45-320

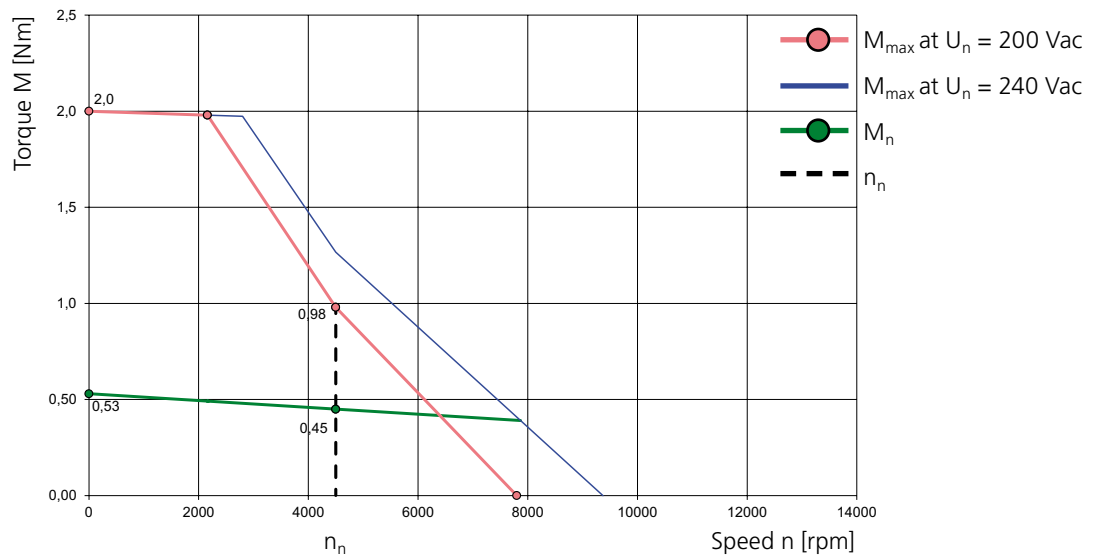

### LSH-050-3-45-320

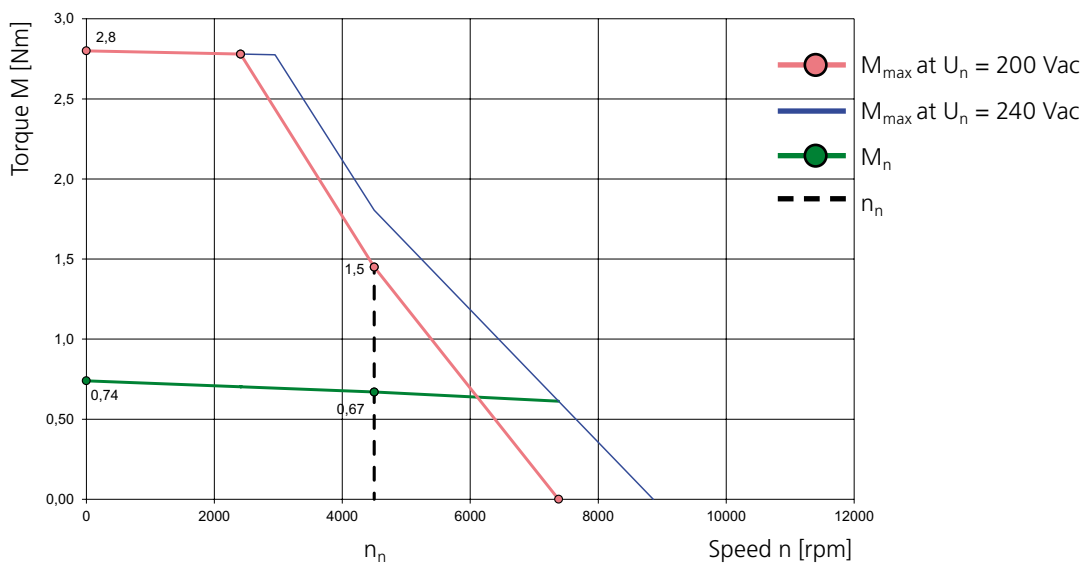

### LSH-050-4-45-320

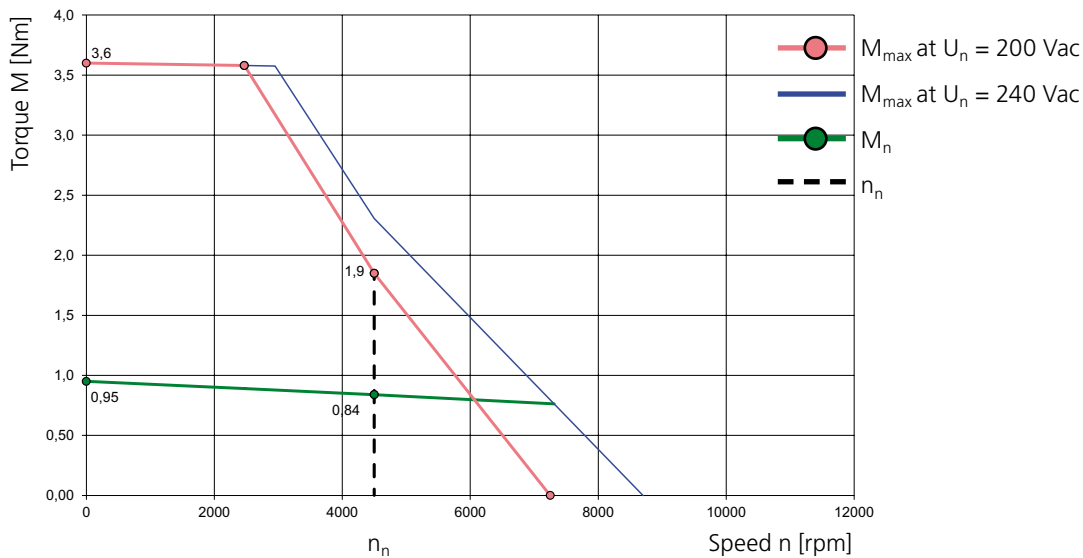

## 4.17 Motor type: LSH-074 ( $U_{dc} = 320\text{ V}$ )



### 4.17.1 Dimensional sketch and technical data

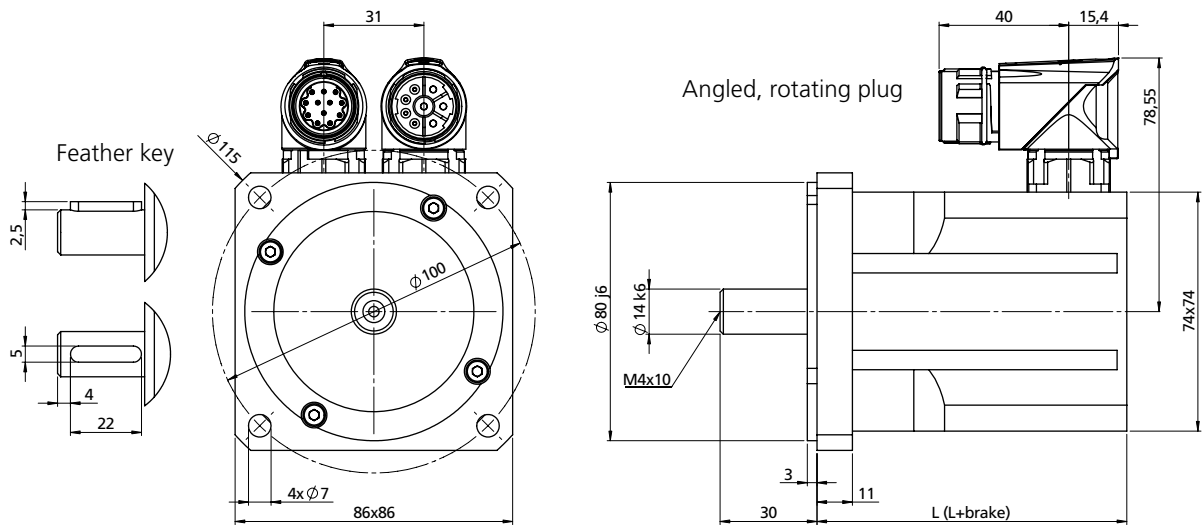

Motor type	L with resolver xR [mm]	L+brake with resolver xR [mm]	L with opt. encoder G12.xy [mm]	L+brake with opt. encoder G12.xy [mm]	L with opt. encoder G6.1x [mm]	L+brake with opt. encoder G6.1x [mm]
LSH-074-1	96	138	137	179	115.5	157.5
LSH-074-2	114	156	155	197	133.5	175.5
LSH-074-3	150	192	191	233	169.5	211.5
LSH-074-4	186	228	227	269	205.5	247.5

Motor type	L with opt. encoder G6.2x [mm]	L+brake with opt. encoder G6.2x [mm]	L with opt. encoder G6.3x [mm]	L+brake with opt. encoder G6.3x [mm]	L with opt. encoder G3/G5 [mm]	L+brake with opt. encoder G3/G5 [mm]
LSH-074-1	113	155	In preparation	In preparation	126	168
LSH-074-2	131	173	In preparation	In preparation	144	186
LSH-074-3	167	209	In preparation	In preparation	180	222
LSH-074-4	203	245	In preparation	In preparation	226	268

Table: Overview of motor lengths – for overview of encoder types see section 5.1

Technical data <sup>1)</sup>	Symbol	LSH-074-1-30-320	LSH-074-2-30-320	LSH-074-3-30-320	LSH-074-4-30-320
Rated speed	$n_n$	3000 rpm	3000 rpm	3000 rpm	3000 rpm
Rated frequency	$f_N$	250 Hz	250 Hz	250 Hz	250 Hz
DC link voltage (controller)	$U_{dc}$	320 V	320 V	320 V	320 V
Rated voltage	$U_n$	200 V	200 V	200 V	200 V
Rated torque	$M_n$	0.86 Nm	1.6 Nm	2.9 Nm	3.1 Nm
Rated current	$I_n$	1.43 A	2.4 A	4.0 A	3.7 A
Rated power	$P$	0.27 kW	0.5 kW	0.91 kW	0.97 kW
Stall torque	$M_0$	0.95 Nm	1.9 Nm	3.3 Nm	4.2 Nm
Stall current	$I_0$	1.47 A	2.8 A	4.3 A	4.8 A
Maximum permissible torque	$M_{max}$	2.4 Nm	5.2 Nm	9.5 Nm	12.3 Nm
Maximum permissible current	$I_{max}$	5.4 A	11.1 A	18.6 A	21.0 A
Maximum permissible speed	$n_{max}$	12000 rpm	12000 rpm	12000 rpm	12000 rpm
Voltage constant	$K_E$	39.0 V/1000 rpm	41.5 V/1000 rpm	46.0 V/1000 rpm	53.0 V/1000 rpm
Torque constant	$K_T$	0.65 Nm/A	0.69 Nm/A	0.76 Nm/A	0.88 Nm/A
Winding resistance (2 phases)	$R_{2ph}$	9.9 $\Omega$	4.0 $\Omega$	2.2 $\Omega$	1.77 $\Omega$
Winding inductance (2 phases)	$L_{2ph}$	30.6 mH	15.4 mH	9.8 mH	10.0 mH
No load speed	$n_0$	5080 rpm	4800 rpm	4340 rpm	3760 rpm
Electrical time constant	$T_{el}$	3.1 ms	3.9 ms	4.5 ms	5.6 ms
Thermal time constant	$T_{th}$	25 min.	30 min.	33 min.	36 min.
Moment of inertia of the motor	$J$	0.000050 kgm <sup>2</sup>	0.000070 kgm <sup>2</sup>	0.00011 kgm <sup>2</sup>	0.00015 kgm <sup>2</sup>
Mass	$m$	1.52 kg	2.09 kg	3.22 kg	4.35 kg

#### Brake (optional)

Rated voltage	$U_N$	24 V $\pm$ 10 %
Rated current at 20 °C for venting	$I_N$	0.5 A
Permissible maximum speed	$n_{max}$	10000 rpm
Permissible friction energy	$W_R$	0.58 x 10 <sup>6</sup> Ws
Mass moment of inertia	$J_B$	0.000018 kgm <sup>2</sup>
Mass	$m$	0.3 kg
Braking torque	$M_H$	4.5 Nm

<sup>1)</sup> All values with a tolerance of  $\pm$  10%.

## 4.17.2 Characteristics

Explanations of characteristics:

The characteristic  $M_{\max}$  describes the maximum possible short-time torque at corresponding speed. It is important for dynamic processes.

The characteristic  $M_n$  indicates the thermally permissible rated torque.

The characteristics are limited by the respective maximum permissible speed  $n_{\max}$  (for  $n_{\max}$  refer to the "Technical data" table).

### LSH-074-1-30-320

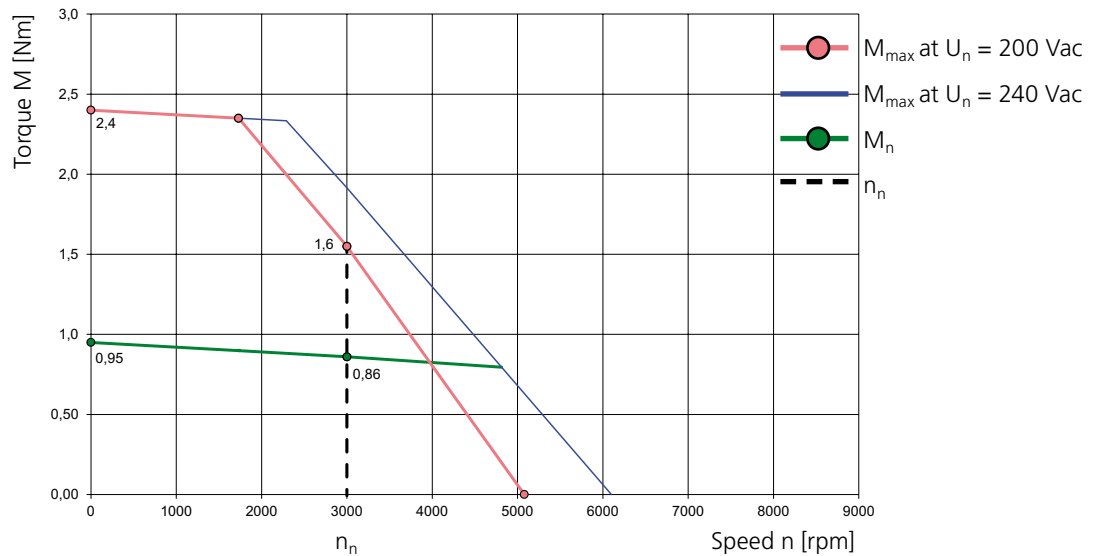

### LSH-074-2-30-320

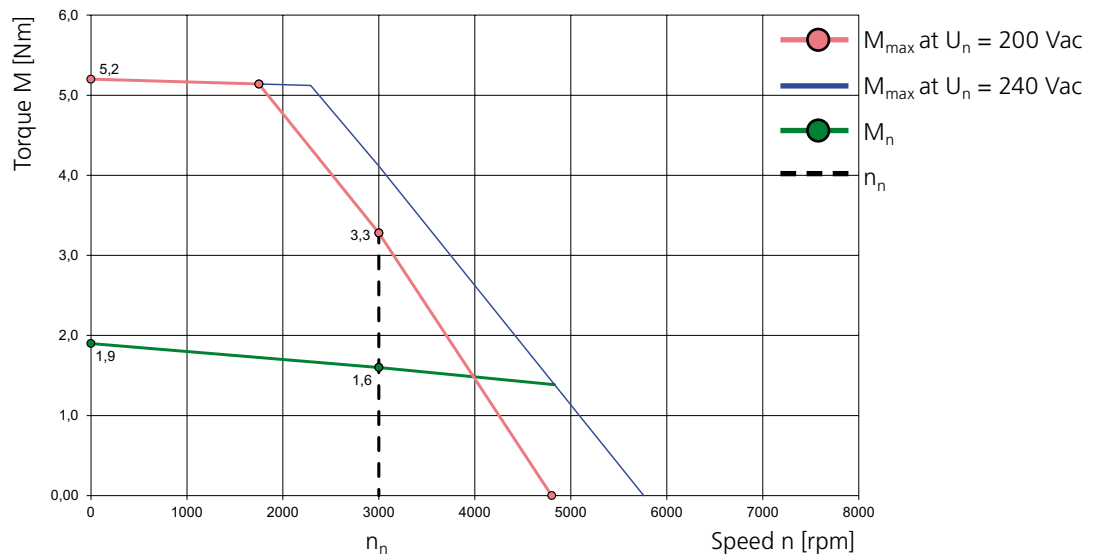

### LSH-074-3-30-320

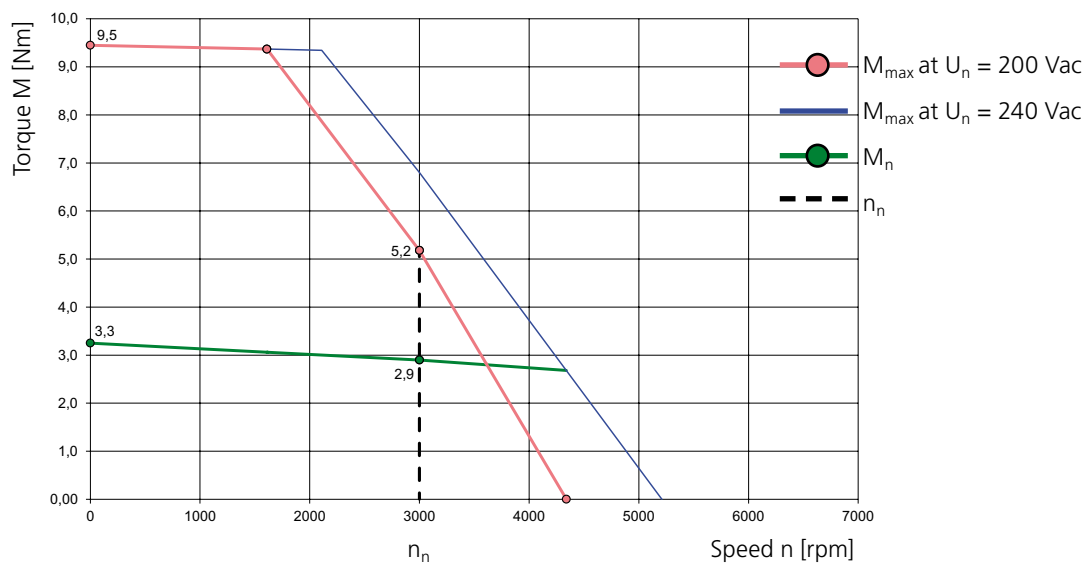

### LSH-074-4-30-320

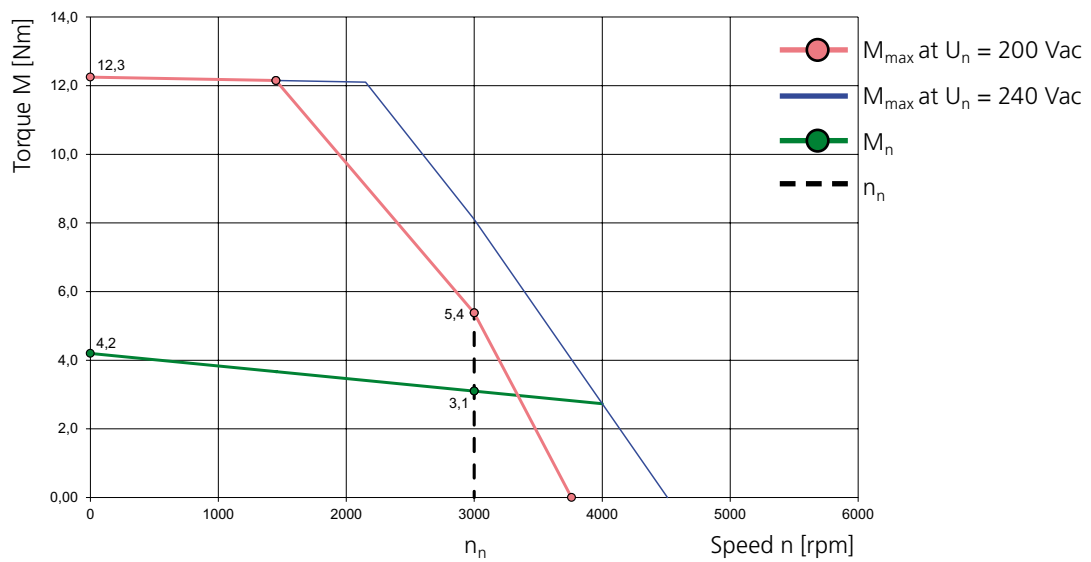

## 4.18 Motor type: LSH-074 ( $U_{dc} = 560 \text{ V}$ )



### 4.18.1 Dimensional sketch and technical data

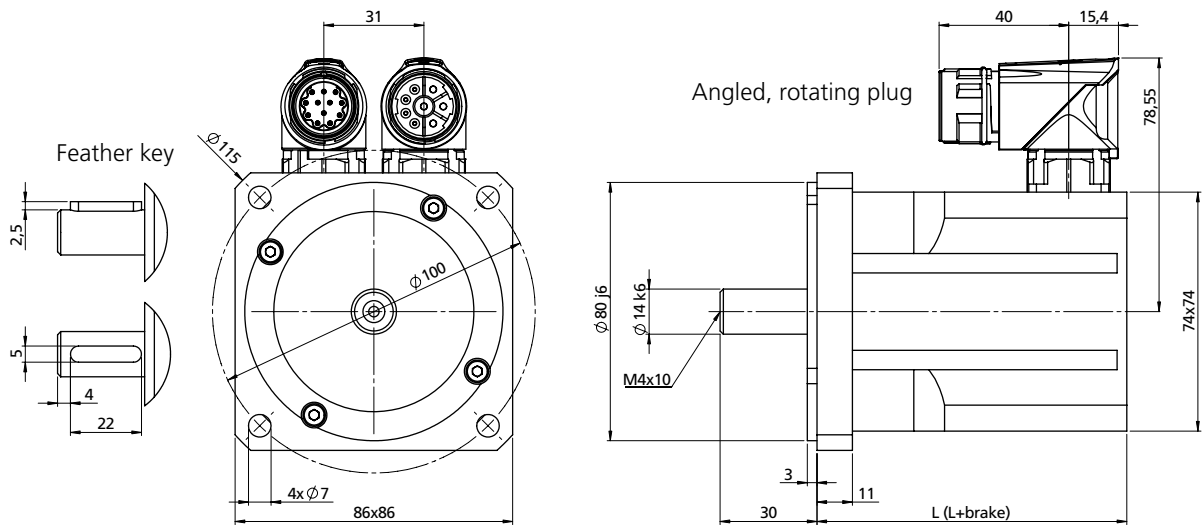

Motor type	L with resolver xR [mm]	L+brake with resolver xR [mm]	L with opt. encoder G12.xy [mm]	L+brake with opt. encoder G12.xy [mm]	L with opt. encoder G6.1x [mm]	L+brake with opt. encoder G6.1x [mm]
LSH-074-1	96	138	137	179	115.5	157.5
LSH-074-2	114	156	155	197	133.5	175.5
LSH-074-3	150	192	191	233	169.5	211.5
LSH-074-4	186	228	227	269	205.5	247.5

Motor type	L with opt. encoder G6.2x [mm]	L+brake with opt. encoder G6.2x [mm]	L with opt. encoder G6.3x [mm]	L+brake with opt. encoder G6.3x [mm]	L with opt. encoder G3/G5 [mm]	L+brake with opt. encoder G3/G5 [mm]
LSH-074-1	113	155	In preparation	In preparation	126	168
LSH-074-2	131	173	In preparation	In preparation	144	186
LSH-074-3	167	209	In preparation	In preparation	180	222
LSH-074-4	203	245	In preparation	In preparation	226	268

Table: Overview of motor lengths – for overview of encoder types see section 5.1



Technical data <sup>1)</sup>	Symbol	LSH-074-1-30-560	LSH-074-2-30-560	LSH-074-3-30-560	LSH-074-4-30-560
Rated speed	$n_n$	3000 rpm	3000 rpm	3000 rpm	3000 rpm
Rated frequency	$f_N$	250 Hz	250 Hz	250 Hz	250 Hz
DC link voltage (controller)	$U_{dc}$	560 V	560 V	560 V	560 V
Rated voltage	$U_n$	330 V	330 V	330 V	330 V
Rated torque	$M_n$	0.86 Nm	1.6 Nm	2.9 Nm	3.1 Nm
Rated current	$I_n$	1.28 A	1.46 A	2.3 A	2.3 A
Rated power	P	0.27 kW	0.5 kW	0.91 kW	0.97 kW
Stall torque	$M_0$	0.95 Nm	1.9 Nm	3.3 Nm	4.2 Nm
Stall current	$I_0$	1.32 A	1.66 A	2.4 A	3.0 A
Maximum permissible torque	$M_{max}$	2.4 Nm	5.2 Nm	9.5 Nm	12.3 Nm
Maximum permissible current	$I_{max}$	4.9 A	6.7 A	10.6 A	12.9 A
Maximum permissible speed	$n_{max}$	12000 rpm	12000 rpm	12000 rpm	12000 rpm
Voltage constant	$K_E$	43.5V/1000 rpm	69.0 V/1000 rpm	81.0 V/1000 rpm	86.0 V/1000 rpm
Torque constant	$K_T$	0.72 Nm/A	1.14 Nm/A	1.34 Nm/A	1.42 Nm/A
Winding resistance (2 phases)	$R_{2ph}$	12.6 $\Omega$	11.6 $\Omega$	6.5 $\Omega$	4.6 $\Omega$
Winding inductance (2 phases)	$L_{2ph}$	38.0 mH	42.3 mH	30.6 mH	26.1 mH
No load speed	$n_0$	7520 rpm	4770 rpm	4060 rpm	3830 rpm
Electrical time constant	$T_{el}$	3.0 ms	3.6 ms	4.7 ms	5.7 ms
Thermal time constant	$T_{th}$	25 min.	30 min.	33 min.	36 min.
Moment of inertia of the motor	J	0.000050 kgm <sup>2</sup>	0.000070 kgm <sup>2</sup>	0.00011 kgm <sup>2</sup>	0.00015 kgm <sup>2</sup>
Mass	m	1.52 kg	2.09 kg	3.22 kg	4.35 kg

#### Brake (optional)

Rated voltage	$U_N$	24 V $\pm$ 10 %
Rated current at 20 °C for venting	$I_N$	0.5 A
Permissible maximum speed	$n_{max}$	10000 rpm
Permissible friction energy	$W_R$	0.58 x 10 <sup>6</sup> Ws
Mass moment of inertia	$J_B$	0.000018 kgm <sup>2</sup>
Mass	m	0.3 kg
Braking torque	$M_H$	4.5 Nm

<sup>1)</sup> All values with a tolerance of  $\pm$  10%.

## 4.18.2 Characteristics

Explanations of characteristics:

The characteristic  $M_{\max}$  describes the maximum possible short-time torque at corresponding speed. It is important for dynamic processes.

The characteristic  $M_n$  indicates the thermally permissible rated torque.

The characteristics are limited by the respective maximum permissible speed  $n_{\max}$  (for  $n_{\max}$  refer to the "Technical data" table).

### LSH-074-1-30-560

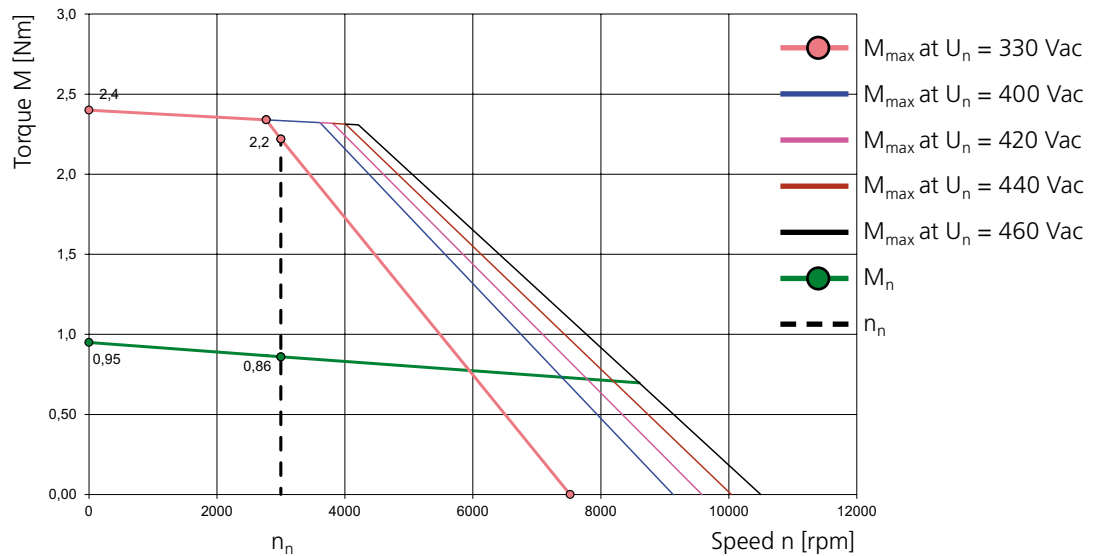

### LSH-074-2-30-560

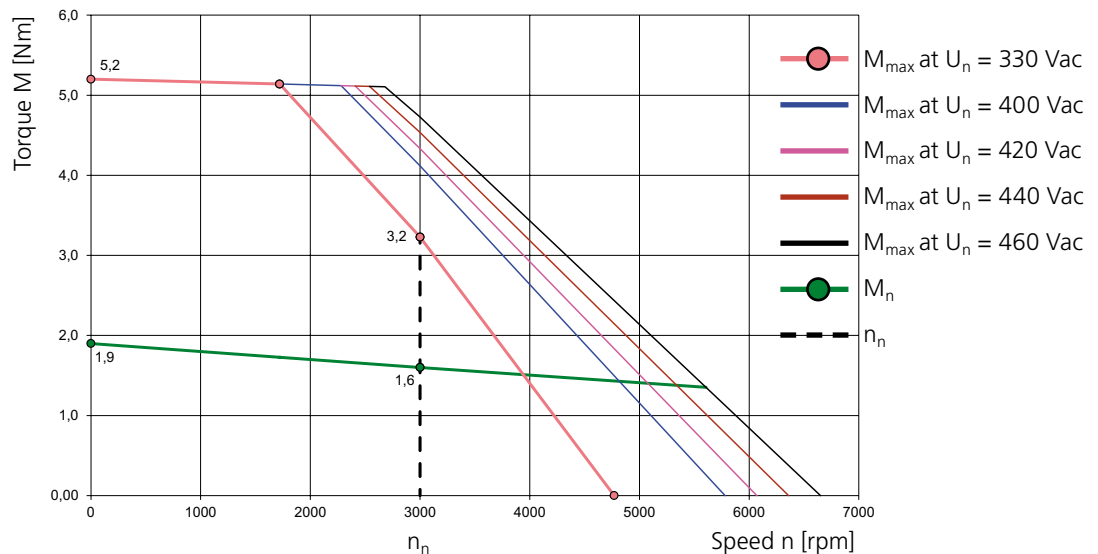

### LSH-074-3-30-560

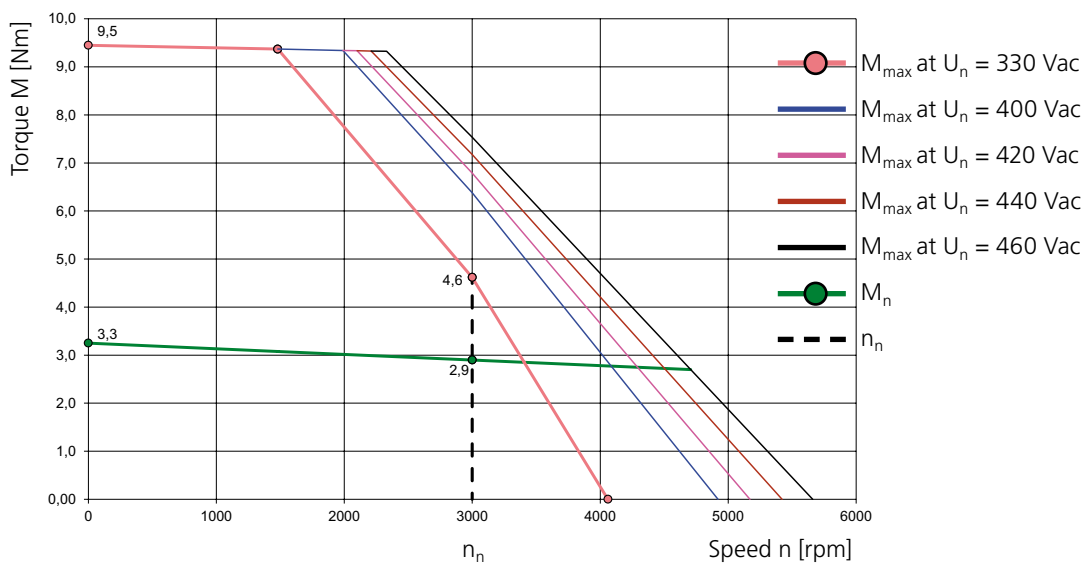

### LSH-074-4-30-560

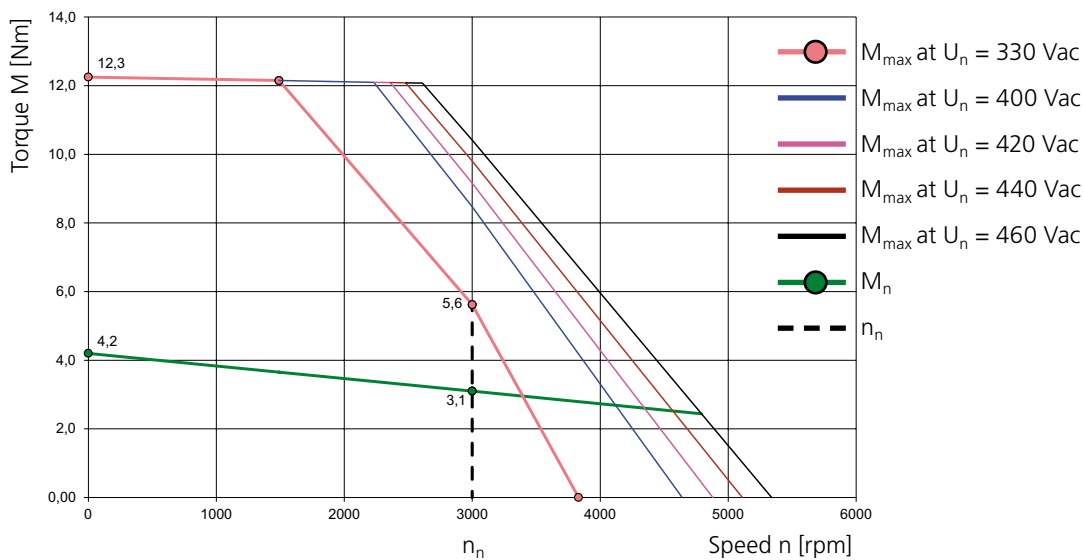

## 4.19 Motor type: LSH-097 ( $U_{dc} = 320\text{ V}$ )



### 4.19.1 Dimensional sketch and technical data

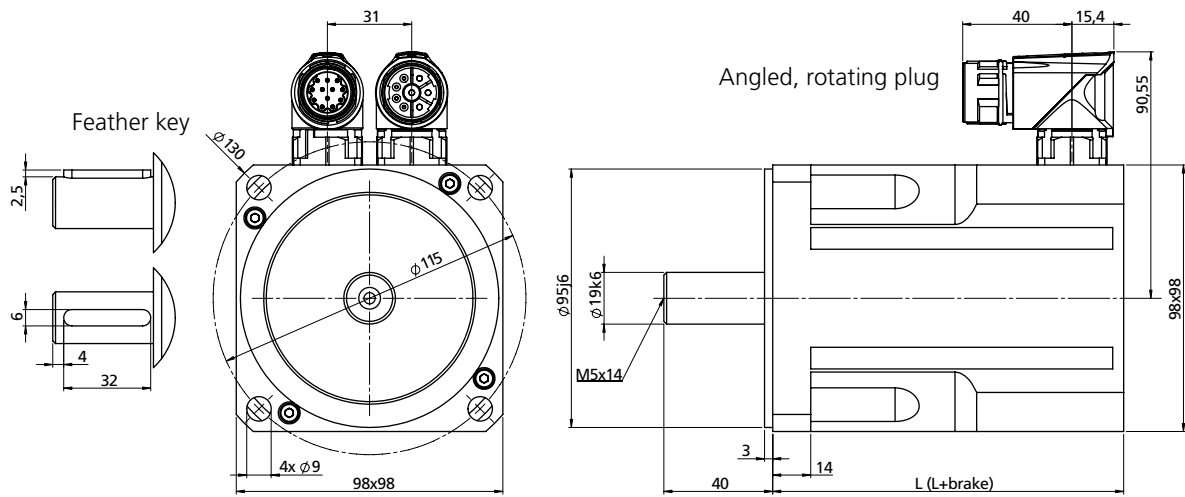

Motor type	L with resolver xR [mm]	L+brake with resolver xR [mm]	L with opt. encoder G12.xy [mm]	L+brake with opt. encoder G12.xy [mm]	L with opt. encoder G6.1x [mm]	L+brake with opt. encoder G6.1x [mm]
LSH-097-1	129	170	166	207	150	191
LSH-097-2	159	200	196	237	180	221
LSH-097-3	189	230	226	267	210	251

Motor type	L with opt. encoder G6.2x [mm]	L+brake with opt. encoder G6.2x [mm]	L with opt. encoder G6.3x [mm]	L+brake with opt. encoder G6.3x [mm]	L with opt. encoder G3/G5 [mm]	L+brake with opt. encoder G3/G5 [mm]
LSH-097-1	148	189	In preparation	In preparation	159	200
LSH-097-2	178	219	In preparation	In preparation	189	230
LSH-097-3	208	249	In preparation	In preparation	219	260

Table: Overview of motor lengths – for overview of encoder types see section 5.1

Technical data <sup>1)</sup>	Symbol	LSH-097-1-30-320	LSH-097-2-30-320	LSH-097-3-30-320
Rated speed	$n_n$	3000 rpm	3000 rpm	3000 rpm
Rated frequency	$f_N$	250 Hz	250 Hz	250 Hz
DC link voltage (controller)	$U_{dc}$	320 V	320 V	320 V
Rated voltage	$U_n$	200 V	200 V	200 V
Rated torque	$M_n$	3.2 Nm	4.6 Nm	6.1 Nm
Rated current	$I_n$	5.0 A	7.0 A	8.3 A
Rated power	$P$	1.0 kW	1.44 kW	1.9 kW
Stall torque	$M_0$	4.1 Nm	6.3 Nm	8.6 Nm
Stall current	$I_0$	6.0 A	9.2 A	11.2 A
Maximum permissible torque	$M_{max}$	11.1 Nm	18.5 Nm	27.0 Nm
Maximum permissible current	$I_{max}$	24.0 A	40.0 A	53.0 A
Maximum permissible speed	$n_{max}$	9000 rpm	9000 rpm	9000 rpm
Voltage constant	$K_E$	40.5 V/1000 rpm	41.5 V/1000 rpm	46.5 V/1000 rpm
Torque constant	$K_T$	0.67 Nm/A	0.69 Nm/A	0.77 Nm/A
Winding resistance (2 phases)	$R_{2ph}$	1.24 $\Omega$	0.7 $\Omega$	0.59 $\Omega$
Winding inductance (2 phases)	$L_{2ph}$	10.6 mH	6.9 mH	6.2 mH
No load speed	$n_0$	4920 rpm	4810 rpm	4290 rpm
Electrical time constant	$T_{el}$	8.5 ms	9.9 ms	10.5 ms
Thermal time constant	$T_{th}$	29 min.	31 min.	33 min.
Moment of inertia of the motor	$J$	0.00017 kgm <sup>2</sup>	0.00026 kgm <sup>2</sup>	0.00035 kgm <sup>2</sup>
Mass	$m$	4.28 kg	5.34 kg	6.96 kg

#### Brake (optional)

Rated voltage	$U_N$	24 V $\pm$ 10 %
Rated current at 20 °C for venting	$I_N$	0.75 A
Permissible maximum speed	$n_{max}$	10000 rpm
Permissible friction energy	$W_R$	0.89 x 10 <sup>6</sup> Ws
Mass moment of inertia	$J_B$	0.000054 kgm <sup>2</sup>
Mass	$m$	0.46 kg
Braking torque	$M_H$	9.0 Nm

<sup>1)</sup> All values with a tolerance of  $\pm$  10%.

## 4.19.2 Characteristics

Explanations of characteristics:

The characteristic  $M_{\max}$  describes the maximum possible short-time torque at corresponding speed. It is important for dynamic processes.

The characteristic  $M_n$  indicates the thermally permissible rated torque.

The characteristics are limited by the respective maximum permissible speed  $n_{\max}$  (for  $n_{\max}$  refer to the "Technical data" table).

### LSH-097-1-30-320

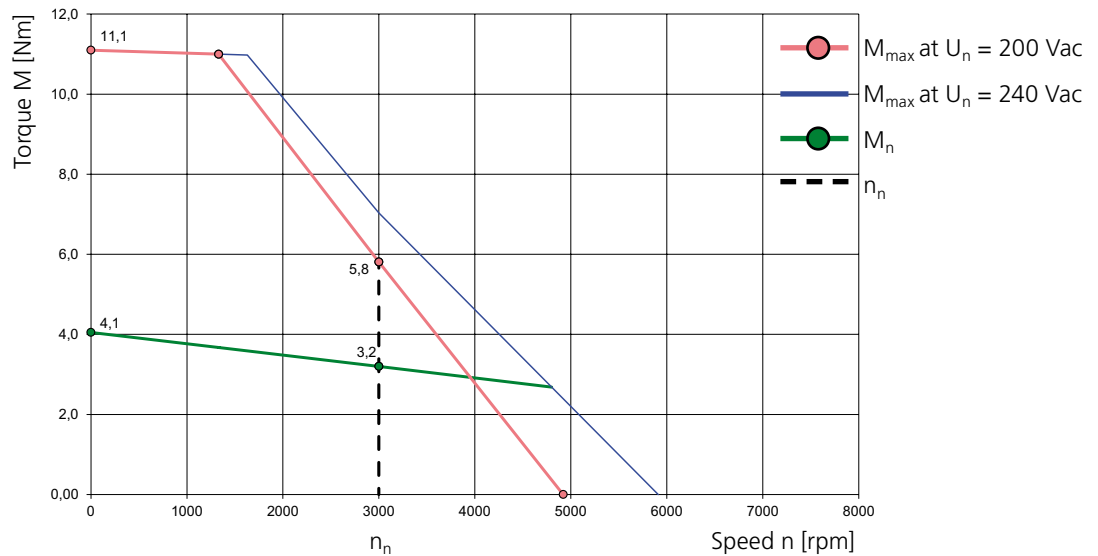

### LSH-097-2-30-320

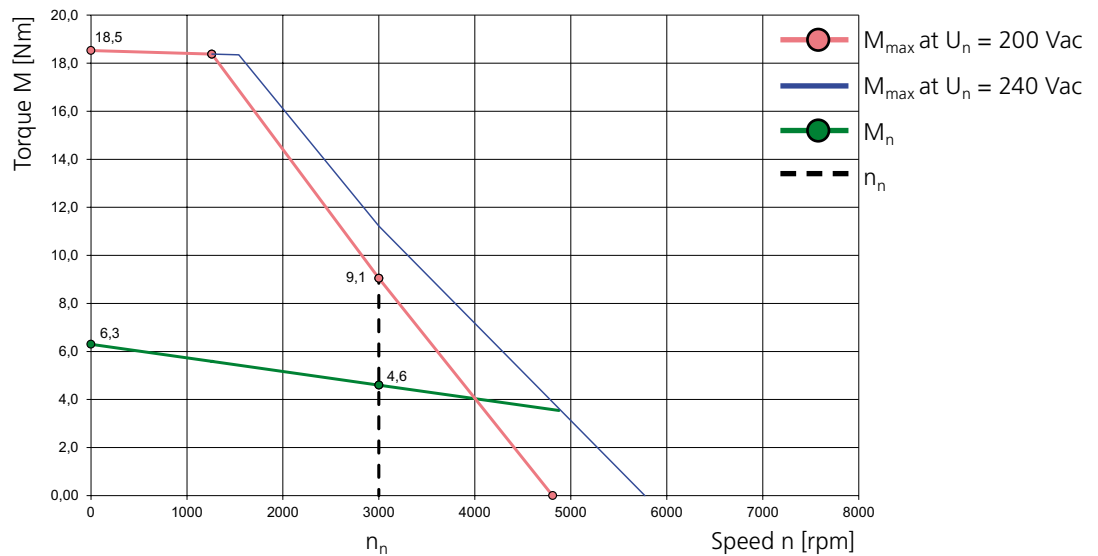

# LSH-097-3-30-320

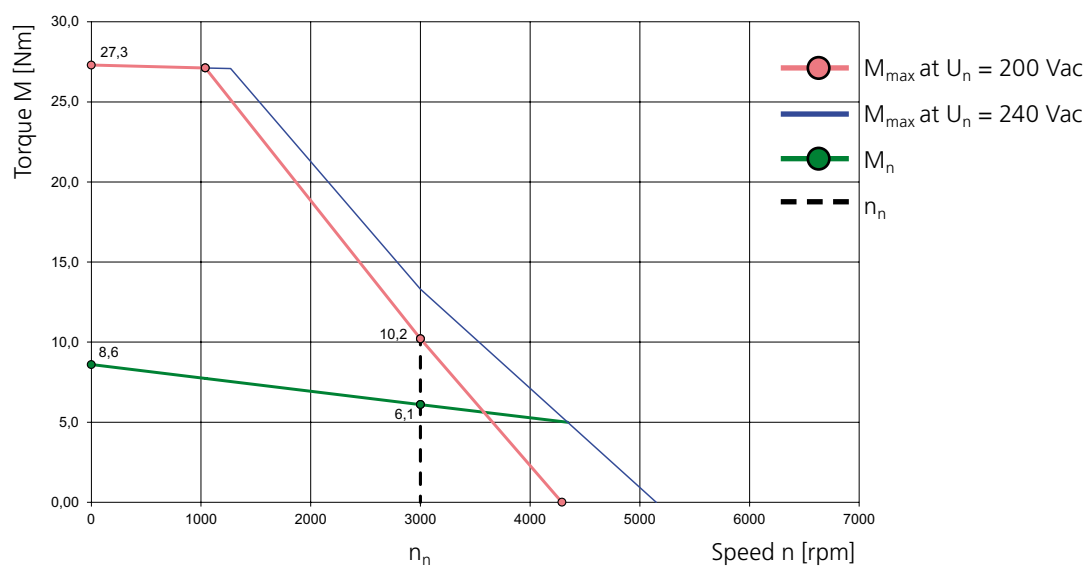

## 4.20 Motor type: LSH-097 ( $U_{dc} = 560\text{ V}$ )



### 4.20.1 Dimensional sketch and technical data

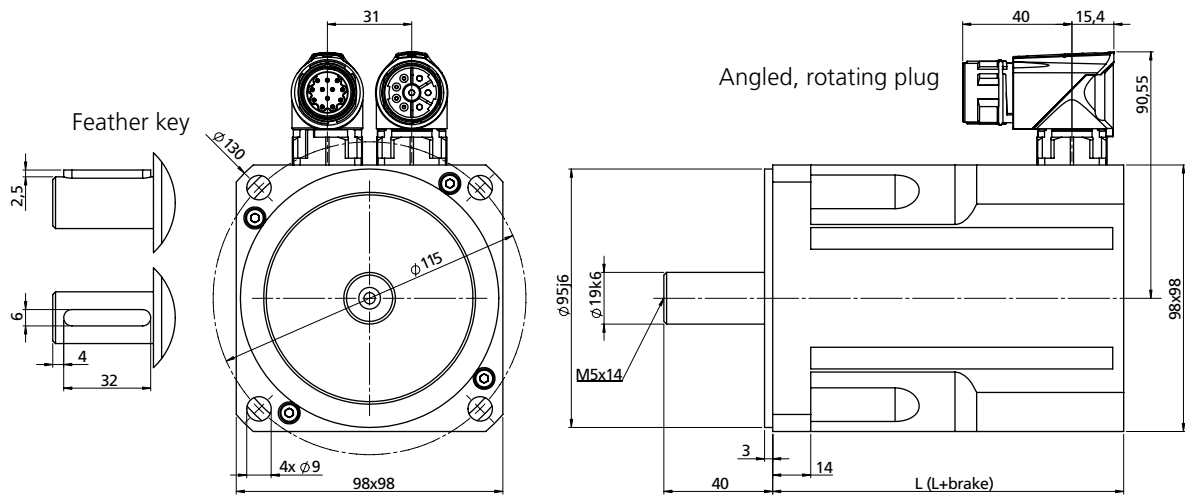

Motor type	L with resolver xR [mm]	L+brake with resolver xR [mm]	L with opt. encoder G12.xy [mm]	L+brake with opt. encoder G12.xy [mm]	L with opt. encoder G6.1x [mm]	L+brake with opt. encoder G6.1x [mm]
LSH-097-1	129	170	166	207	150	191
LSH-097-2	159	200	196	237	180	221
LSH-097-3	189	230	226	267	210	251

Motor type	L with opt. encoder G6.2x [mm]	L+brake with opt. encoder G6.2x [mm]	L with opt. encoder G6.3x [mm]	L+brake with opt. encoder G6.3x [mm]	L with opt. encoder G3/G5 [mm]	L+brake with opt. encoder G3/G5 [mm]
LSH-097-1	148	189	In preparation	In preparation	159	200
LSH-097-2	178	219	In preparation	In preparation	189	230
LSH-097-3	208	249	In preparation	In preparation	219	260

Table: Overview of motor lengths – for overview of encoder types see section 5.1



Technical data <sup>1)</sup>	Symbol	LSH-097-1-30-560	LSH-097-2-30-560	LSH-097-3-30-560
Rated speed	$n_n$	3000 rpm	3000 rpm	3000 rpm
Rated frequency	$f_N$	250 Hz	250 Hz	250 Hz
DC link voltage (controller)	$U_{dc}$	560 V	560 V	560 V
Rated voltage	$U_n$	330 V	330 V	330 V
Rated torque	$M_n$	3.2 Nm	4.6 Nm	6.1 Nm
Rated current	$I_n$	2.8 A	3.6 A	4.8 A
Rated power	$P$	1.0 kW	1.44 kW	1.9 kW
Stall torque	$M_0$	4.1 Nm	6.3 Nm	8.6 Nm
Stall current	$I_0$	3.4 A	4.8 A	6.4 A
Maximum permissible torque	$M_{max}$	11.1 Nm	18.5 Nm	27.0 Nm
Maximum permissible current	$I_{max}$	13.6 A	21.0 A	31.0 A
Maximum permissible speed	$n_{max}$	6000 rpm	6000 rpm	6000 rpm
Voltage constant	$K_E$	72.0 V/1000 rpm	80.0 V/1000 rpm	81.0 V/1000 rpm
Torque constant	$K_T$	1.19 Nm/A	1.32 Nm/A	1.34 Nm/A
Winding resistance (2 phases)	$R_{2ph}$	4.0 $\Omega$	2.7 $\Omega$	1.81 $\Omega$
Winding inductance (2 phases)	$L_{2ph}$	34.0 mH	25.5 mH	18.6 mH
No load speed	$n_0$	4570 rpm	4120 rpm	4070 rpm
Electrical time constant	$T_{el}$	8.5 ms	9.5 ms	10.3 ms
Thermal time constant	$T_{th}$	29 min.	31 min.	33 min.
Moment of inertia of the motor	$J$	0.00017 kgm <sup>2</sup>	0.00026 kgm <sup>2</sup>	0.00035 kgm <sup>2</sup>
Mass	$m$	4.28 kg	5.34 kg	6.96 kg

#### Brake (optional)

Rated voltage	$U_N$	24 V $\pm$ 10 %
Rated current at 20 °C for venting	$I_N$	0.75 A
Permissible maximum speed	$n_{max}$	10000 rpm
Permissible friction energy	$W_R$	0.89 x 10 <sup>6</sup> Ws
Mass moment of inertia	$J_B$	0.000054 kgm <sup>2</sup>
Mass	$m$	0.46 kg
Braking torque	$M_H$	9.0 Nm

<sup>1)</sup> All values with a tolerance of  $\pm$  10%.

## 4.20.2 Characteristics

Explanations of characteristics:

The characteristic  $M_{max}$  describes the maximum possible short-time torque at corresponding speed. It is important for dynamic processes.

The characteristic  $M_n$  indicates the thermally permissible rated torque.

The characteristics are limited by the respective maximum permissible speed  $n_{max}$  (for  $n_{max}$  refer to the "Technical data" table).

### LSH-097-1-30-560

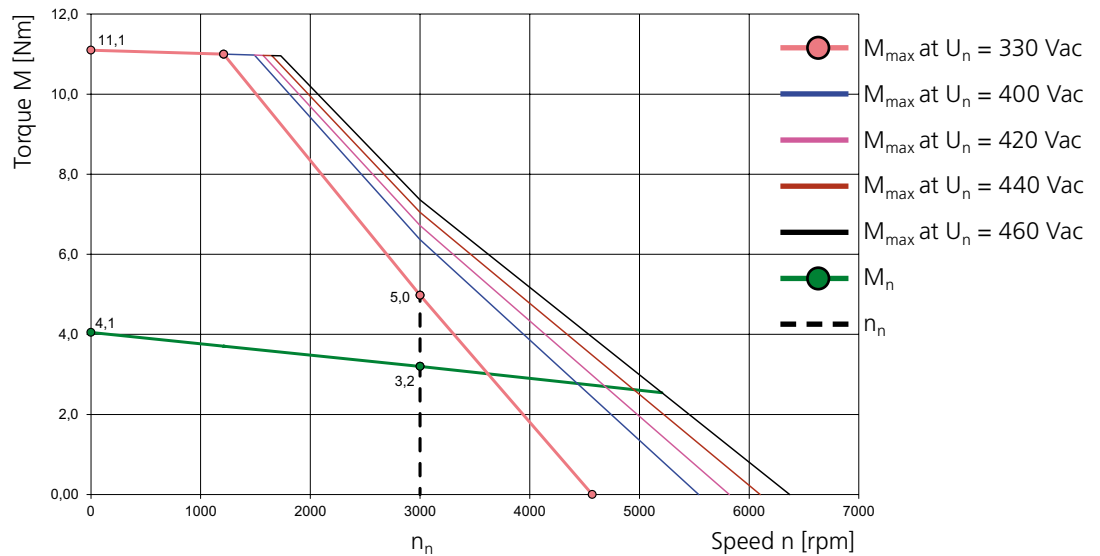

### LSH-097-2-30-560

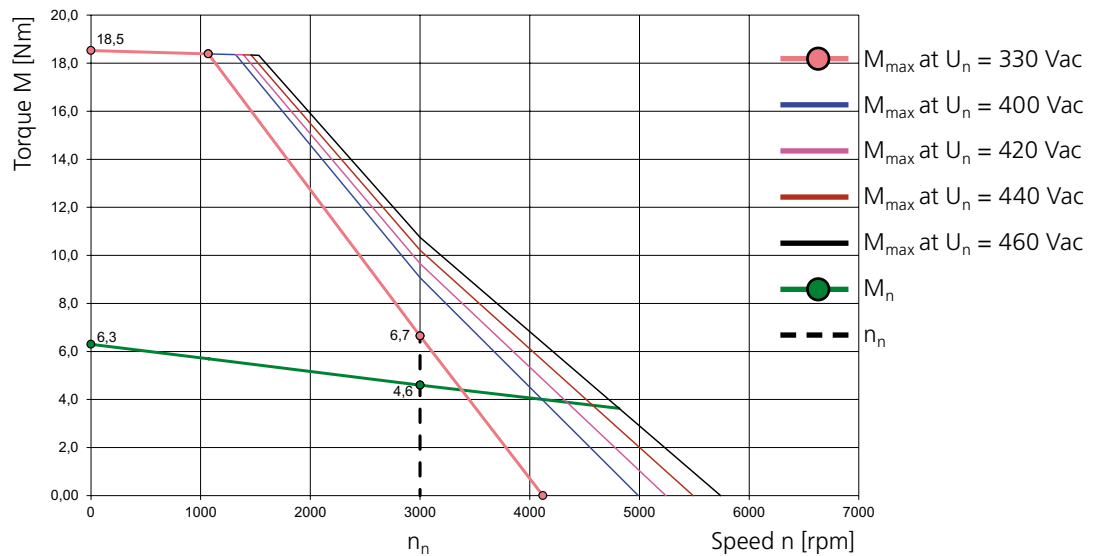

# LSH-097-3-30-560

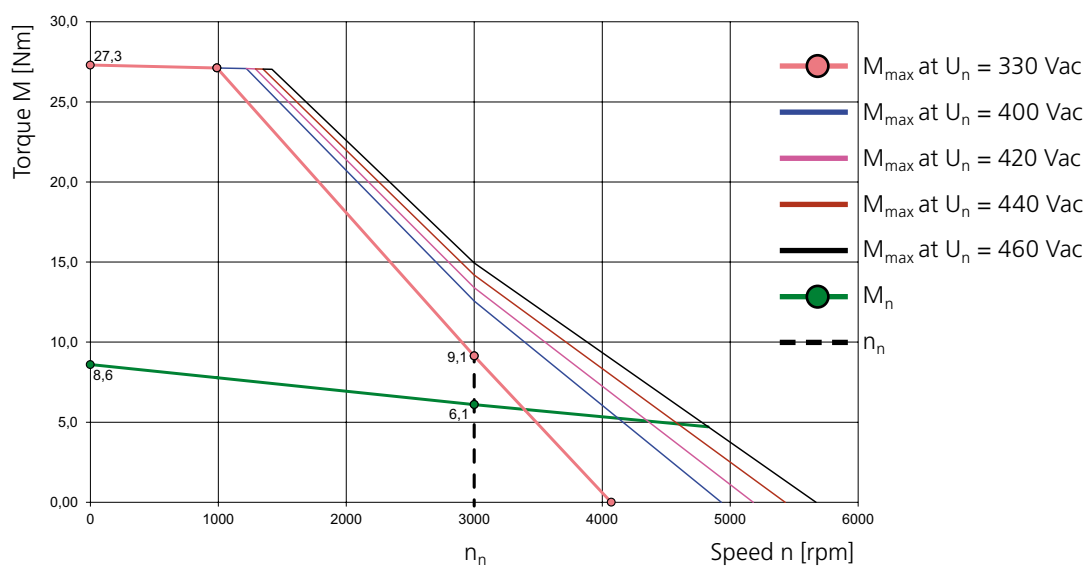

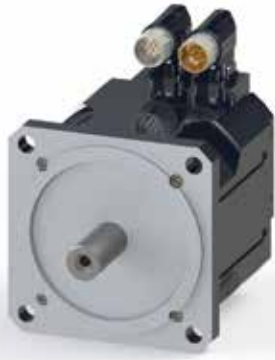

## 4.21 Motor type: LSH-127 ( $U_{dc} = 560\text{ V}$ )

### 4.21.1 Dimensional sketch and technical data

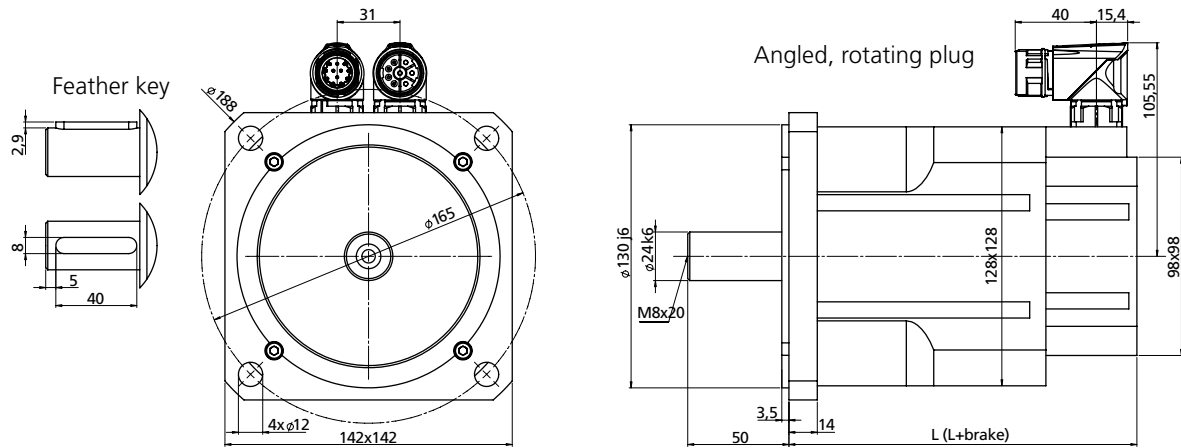

Motor type	L with resolver xR [mm]	L+brake with resolver xR [mm]	L with opt. encoder G12.xy [mm]	L+brake with opt. encoder G12.xy [mm]	L with opt. encoder G6.1x [mm]	L+brake with opt. encoder G6.1x [mm]
LSH-127-1	172	224	192	244	175	226
LSH-127-2	200	252	220	272	203	254
LSH-127-3	230	282	250	302	233	284
LSH-127-4	290	342	310	362	293	344

Motor type	L with opt. encoder G6.2x [mm]	L+brake with opt. encoder G6.2x [mm]	L with opt. encoder G6.3x [mm]	L+brake with opt. encoder G6.3x [mm]	L with opt. encoder G3/G5 [mm]	L+brake with opt. encoder G3/G5 [mm]
LSH-127-1	172	224	In preparation	In preparation	185	237
LSH-127-2	200	252	In preparation	In preparation	213	265
LSH-127-3	230	282	In preparation	In preparation	243	295
LSH-127-4	290	342	In preparation	In preparation	303	355

Table: Overview of motor lengths – for overview of encoder types see section 5.1

Technical data <sup>1)</sup>	Symbol	LSH-127-1-30-560	LSH-127-2-30-560	LSH-127-3-30-560	LSH-127-4-30-560
Rated speed	$n_n$	3000 rpm	3000 rpm	3000 rpm	3000 rpm
Rated frequency	$f_N$	250 Hz	250 Hz	250 Hz	250 Hz
DC link voltage (controller)	$U_{dc}$	560 V	560 V	560 V	560 V
Rated voltage	$U_n$	330 V	330 V	330 V	330 V
Rated torque	$M_n$	8.4 Nm	10.9 Nm	14.3 Nm	21.0 Nm
Rated current	$I_n$	7.9 A	9.6 A	13.1 A	14.9 A
Rated power	P	2.63 kW	3.42 kW	4.11 kW	6.60 kW
Stall torque	$M_0$	11.6 Nm	14.9 Nm	18.7 Nm	27.3 Nm
Stall current	$I_0$	10.3 A	12.5 A	16.4 A	19.0 A
Maximum permissible torque	$M_{max}$	32 Nm	41.0 Nm	51.0 Nm	75.0 Nm
Maximum permissible current	$I_{max}$	49.0 A	49.0 A	61.0 A	68.0 A
Maximum permissible speed	$n_{max}$	9000 rpm	9000 rpm	9000 rpm	9000 rpm
Voltage constant	$K_E$	68.0 V/1000 rpm	72.0 V/1000 rpm	74.0 V/1000 rpm	87.0 V/1000 rpm
Torque constant	$K_T$	1.12 Nm/A	1.19 Nm/A	1.14 Nm/A	1.44 Nm/A
Winding resistance (2 phases)	$R_{2ph}$	0.71 $\Omega$	0.48 $\Omega$	0.35 $\Omega$	0.32 $\Omega$
Winding inductance (2 phases)	$L_{2ph}$	11.4 mH	8.5 mH	6.4 mH	6.8 mH
No load speed	$n_0$	4840 rpm	4580 rpm	4780 rpm	3790 rpm
Electrical time constant	$T_{el}$	16.1 ms	17.7 ms	18.3 ms	21 ms
Thermal time constant	$T_{th}$	50 min.	55 min.	60 min.	75 min.
Moment of inertia of the motor	J	0.00068 kgm <sup>2</sup>	0.00083 kgm <sup>2</sup>	0.00110 kgm <sup>2</sup>	0.00153 kgm <sup>2</sup>
Mass	m	8.1 kg	10.1 kg	12.1 kg	16.1 kg

#### Brake (optional)

Rated voltage	$U_N$	24 V $\pm$ 10 %
Rated current at 20 °C for venting	$I_N$	1.0 A
Permissible maximum speed	$n_{max}$	10000 rpm
Permissible friction energy	$W_R$	1.29 x 10 <sup>6</sup> Ws
Mass moment of inertia	$J_B$	0.000166 kgm <sup>2</sup>
Mass	m	0.9 kg
Braking torque	$M_H$	18 Nm

<sup>1)</sup> All values with a tolerance of  $\pm$  10%.

## 4.21.2 Characteristics

Explanations of characteristics:

The characteristic  $M_{\max}$  describes the maximum possible short-time torque at corresponding speed. It is important for dynamic processes.

The characteristic  $M_n$  indicates the thermally permissible rated torque.

The characteristics are limited by the respective maximum permissible speed  $n_{\max}$  (for  $n_{\max}$  refer to the "Technical data" table).

### LSH-127-1-30-560

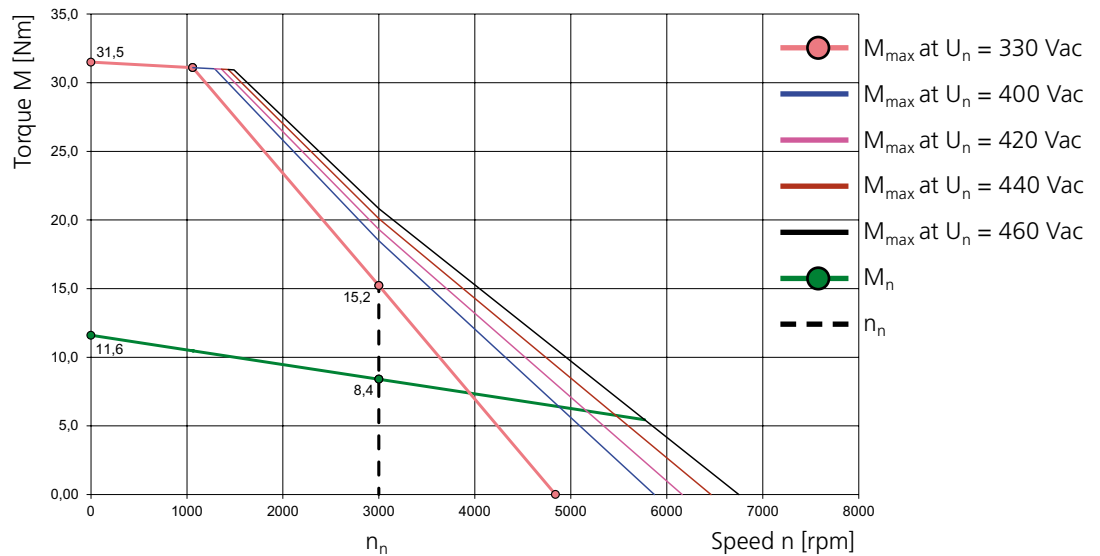

### LSH-127-2-30-560

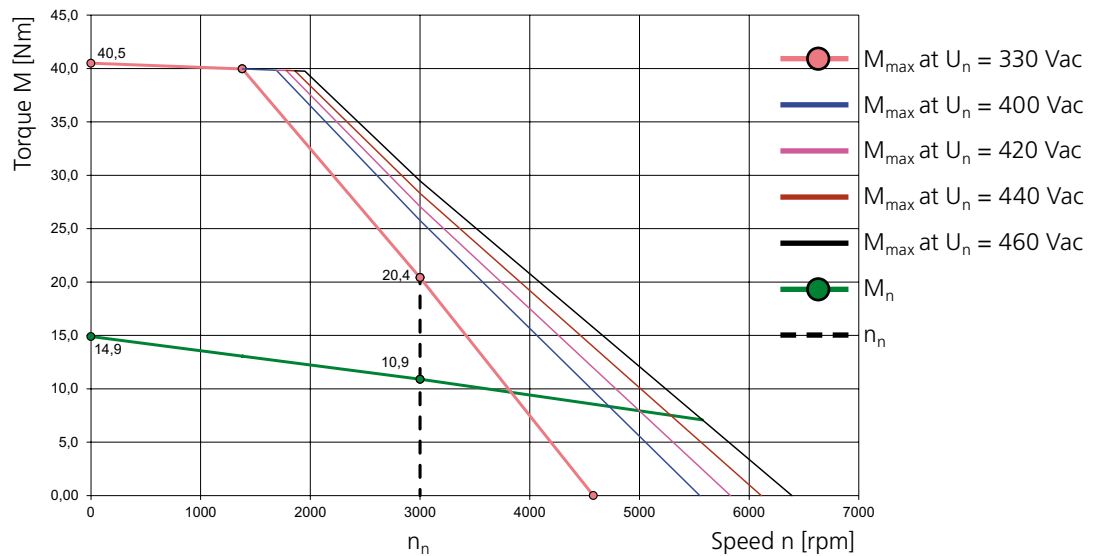

### LSH-127-3-30-560

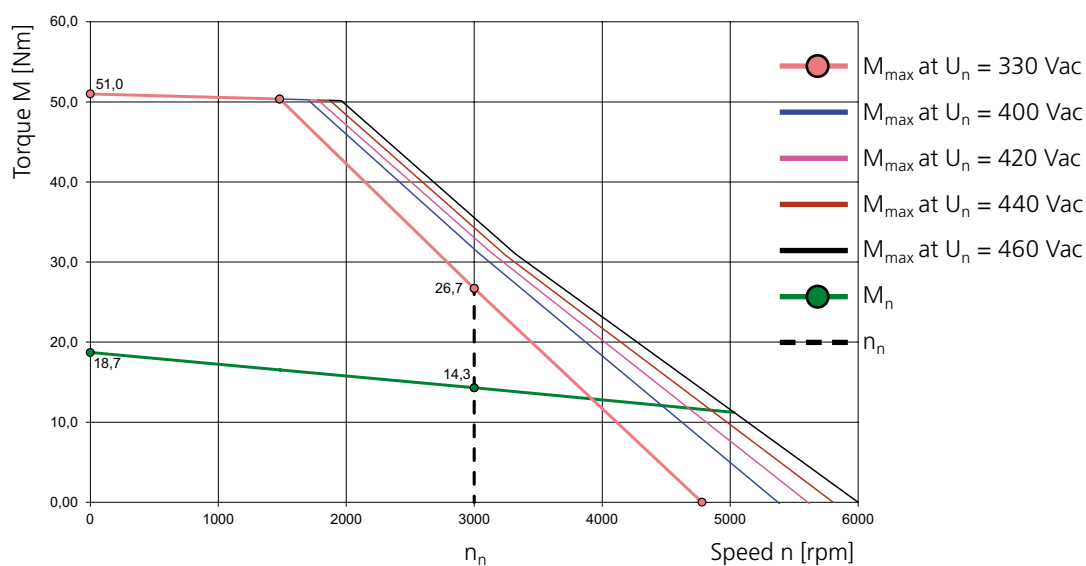

### LSH-127-4-30-560

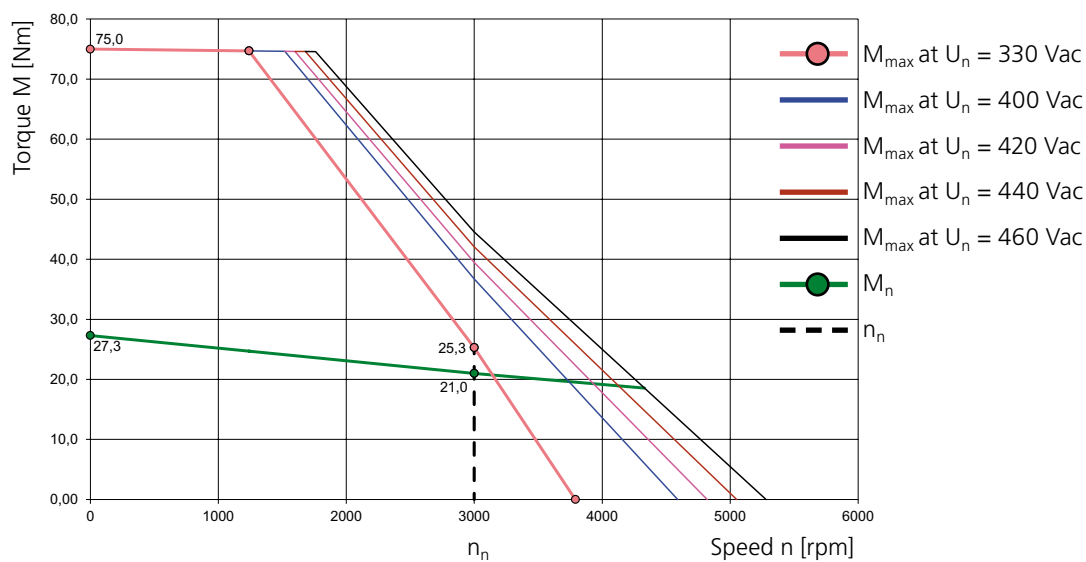

Space for notes

A large grid of graph paper for taking notes, consisting of 20 columns and 30 rows of small squares.



## 4.22 LSH servomotors for functional extra-low voltage (24 V/48 V windings)



The servomotors of the LSH series are also available with motor windings for functional extra-low voltage to IEC 364 (VDE0100, part 410). Together with the servocontroller CDF3000, they offer the optimum combination for this voltage range. LSH servomotors can optionally be run with 24 V or 48 V DC link voltage.

### Technical data

Motor type	Stall torque $M_0$ [Nm]	Rated torque $M_n$ [Nm]	Rated current at 24 V $I_n$ [A]	Rated current at 48 V $I_n$ [A]	Rated speed $n_n$ [rpm] at 24 V	Rated speed $n_n$ [rpm] at 48 V
LSH-050-1-30-24	0.26	0.25	7.54	-	3000	-
LSH-050-2-30-24	0.53	0.49	11.90	-	3000	-
LSH-050-3-30-24	0.74	0.70	16.83	-	3000	-
LSH-050-1-30-48	0.26	0.25	-	3.2	-	3000
LSH-050-2-30-48	0.53	0.49	-	5.6	-	3000
LSH-050-3-30-48	0.74	0.70	-	7.3	-	3000
LSH-074-1-15-24	0.95	0.91	10.6	-	1500	-
LSH-074-1-20-48	0.95	0.90	-	7.6	-	2000

Table: Technical data of the LST servomotor series for functional extra-low voltage – all values with a tolerance of  $\pm 5\%$

## 4.23 Motor type: LSH-050 ( $U_{dc} = 24\text{ V}$ )



### 4.23.1 Dimensional sketch and technical data

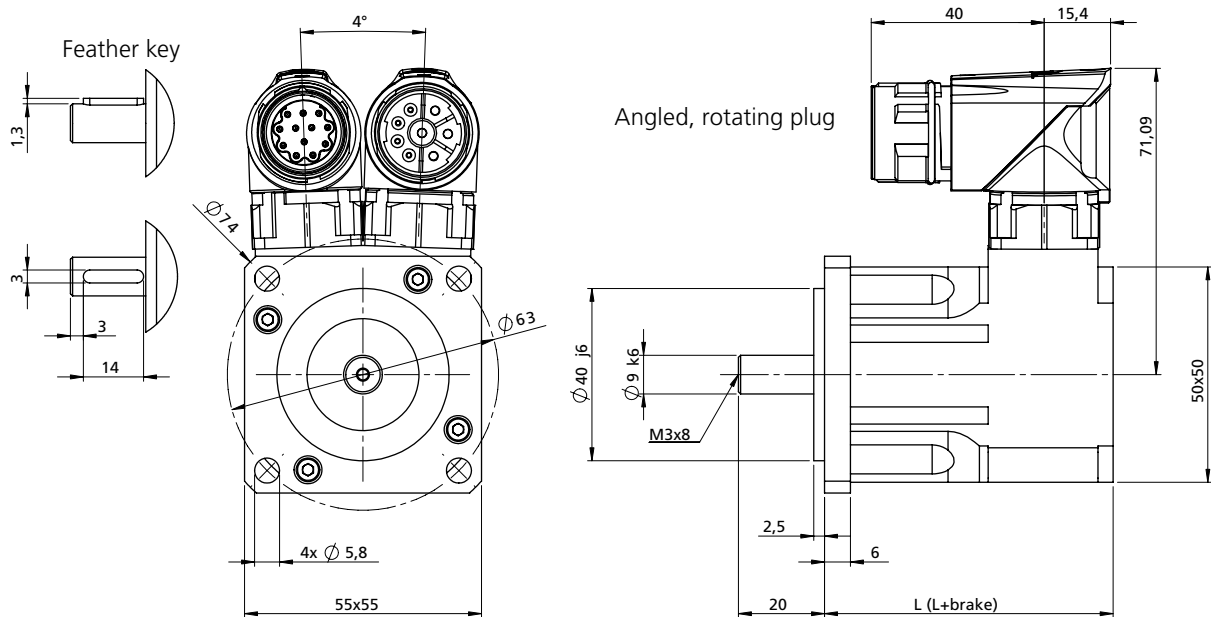

LST servomotors can optionally be run with 24 V or 48 V DC link voltage.

Motor type	L with resolver xR [mm]	L+brake with resolver xR [mm]	L with opt. encoder G12.xy [mm]	L+brake with opt. encoder G12.xy [mm]	L with opt. encoder G6.1x [mm]	L+brake with opt. encoder G6.1x [mm]
LSH-050-1-30-24	67	105	130.5	168.5	In preparation	In preparation
LSH-050-2-30-24	82	120	145.5	183.5	In preparation	In preparation
LSH-050-3-30-24	97	135	160.5	198.5	In preparation	In preparation

Motor type	L with opt. encoder G6.2x [mm]	L+brake with opt. encoder G6.2x [mm]	L with opt. encoder G6.3x [mm]	L+brake with opt. encoder G6.3x [mm]	L with opt. encoder G3/G5 [mm]	L+brake with opt. encoder G3/G5 [mm]
LSH-050-1-30-24	98	133	In preparation	In preparation	106.5	144.5
LSH-050-2-30-24	113	148	In preparation	In preparation	121.5	159.5
LSH-050-3-30-24	128	163	In preparation	In preparation	136.5	174.5

Table: Overview of motor lengths – for overview of encoder types see section 5.1

Technical data <sup>1)</sup>	Symbol	LSH-050-1-30-24	LSH-050-2-30-24	LSH-050-3-30-24
Rated speed	$n_n$	3000 rpm	3000 rpm	3000 rpm
Rated frequency	$f_N$	50 Hz	50 Hz	50 Hz
DC link voltage (controller)	$U_{dc}$	24 V	24 V	24 V
Rated voltage	$U_n$	15 V	15 V	15 V
Rated torque	$M_n$	0.25 Nm	0.49 Nm	0.70 Nm
Rated current	$I_n$	7.54 A	11.9 A	16.83 A
Rated power	P	0.079 kW	0.154 kW	0.220 kW
Stall torque	$M_0$	0.26 Nm	0.53 Nm	0.74 Nm
Stall current	$I_0$	7.5 A	12.4 A	17.3 A
Maximum permissible torque	$M_{max}$	1.0 Nm	2.0 Nm	2.8 Nm
Maximum permissible current	$I_{max}$	30.8 A	50.4 A	70.3 A
Maximum permissible speed	$n_{max}$	12000 rpm	12000 rpm	12000 rpm
Voltage constant	$K_E$	2.1 V/1000 rpm	2.6 V/1000 rpm	2.6 V/1000 rpm
Torque constant	$K_T$	0.03 Nm/A	0.04 Nm/A	0.04 Nm/A
Winding resistance (2 phases)	$R_{2ph}$	0.37 $\Omega$	0.18 $\Omega$	0.11 $\Omega$
Winding inductance (2 phases)	$L_{2ph}$	0.60 mH	0.37 mH	0.25 mH
No load speed	$n_0$	7000 rpm	5770 rpm	5760 rpm
Electrical time constant	$T_{el}$	1.62 ms	2.06 ms	2.27 ms
Thermal time constant	$T_{th}$	13 min.	15 min.	20 min.
Moment of inertia of the motor	J	0.000006 kgm <sup>2</sup>	0.000008 kgm <sup>2</sup>	0.00001 kgm <sup>2</sup>
Mass	m	0.75 kg	0.92 kg	1.09 kg

#### Brake (optional)

Rated voltage	$U_N$	24 V $\pm$ 10 %
Rated current at 20 °C for venting	$I_N$	0.46 A
Permissible maximum speed	$n_{max}$	10000 rpm
Permissible friction energy	$W_R$	0.41 x 10 <sup>6</sup> Ws
Mass moment of inertia	$J_B$	0.000007 kgm <sup>2</sup>
Mass	m	0.15 kg
Braking torque	$M_H$	2 Nm

1) All values with a tolerance of  $\pm$  10%.

## 4.23.2 Characteristics

Explanations of characteristics:

The characteristic  $M_{\max}$  describes the maximum possible short-time torque at corresponding speed. It is important for dynamic processes.

The characteristic  $M_n$  indicates the thermally permissible rated torque.

The characteristics are limited by the respective maximum permissible speed  $n_{\max}$  (for  $n_{\max}$  refer to the "Technical data" table).



**NOTE:** LSH servomotors for functional extra-low voltage can optionally be run with 24 V or 48 V DC link voltage.

### LSH-050-1-30-24

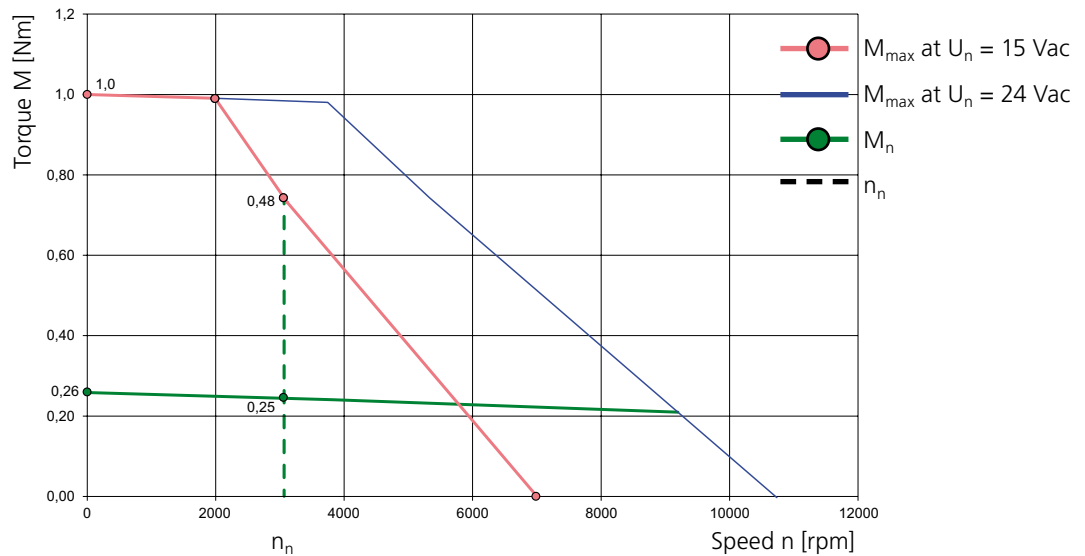

### LSH-050-2-30-24

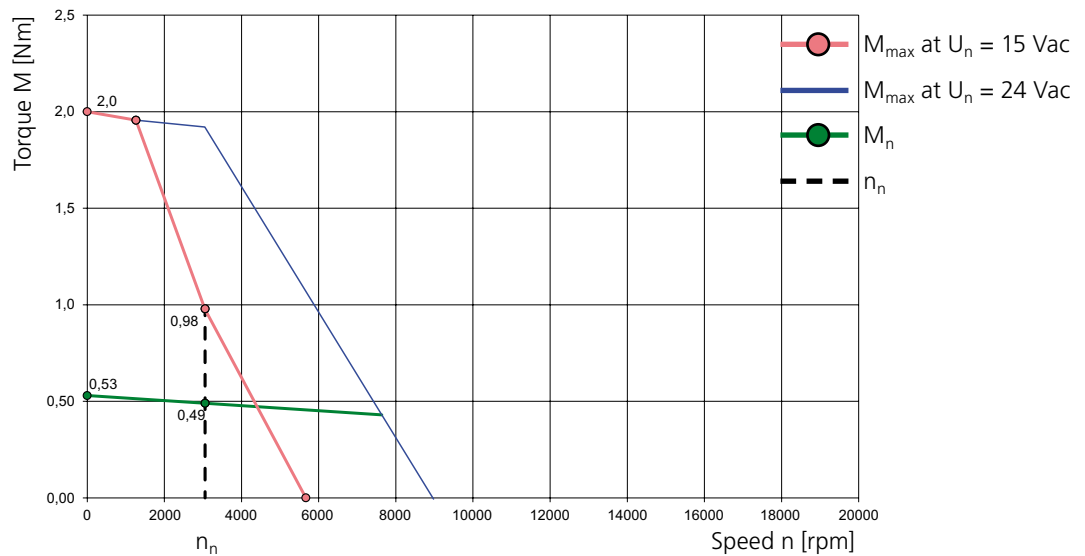

# LSH-050-3-30-24

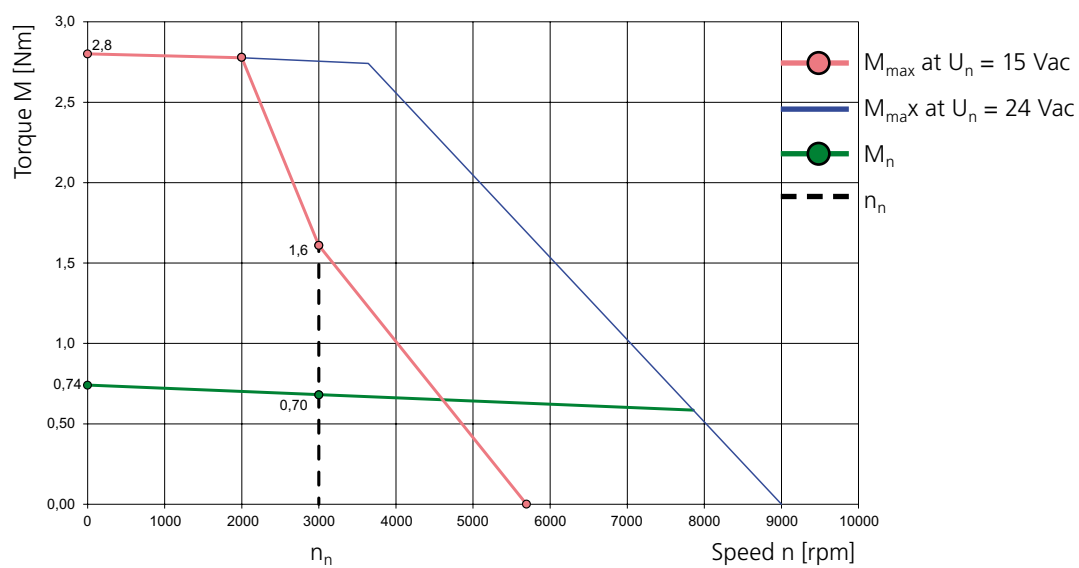

## 4.24 Motor type: LSH-050 ( $U_{dc} = 48\text{ V}$ )



### 4.24.1 Dimensional sketch and technical data

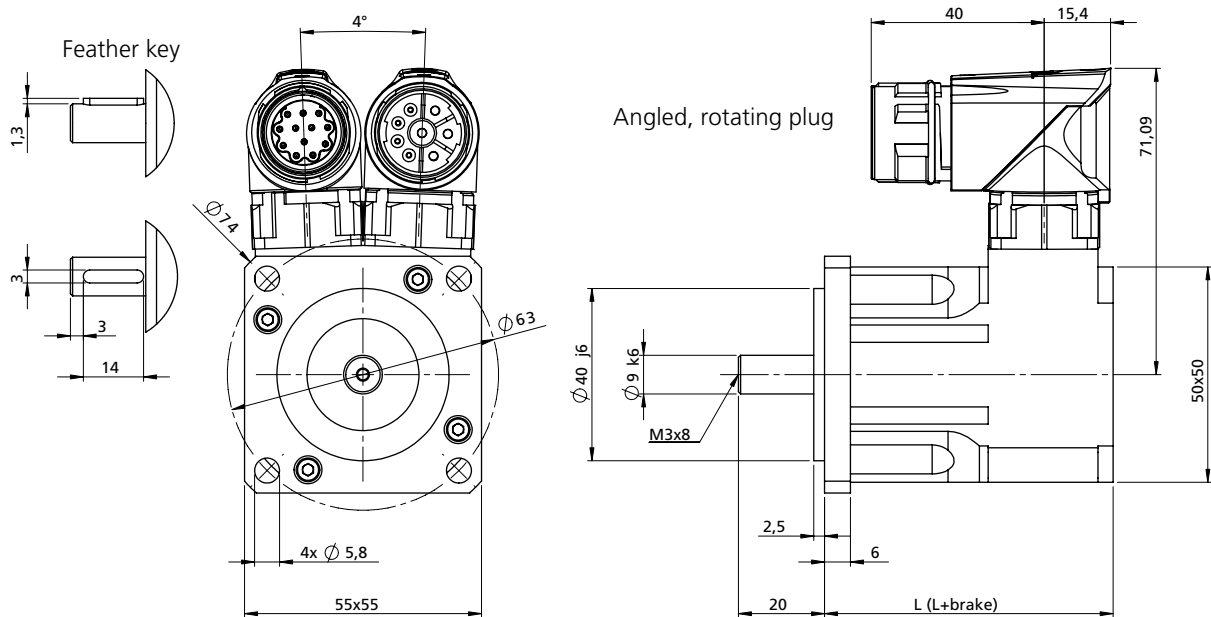

LST servomotors can optionally be run with 24 V or 48 V DC link voltage.

Motor type	L with resolver xR [mm]	L+brake with resolver xR [mm]	L with opt. encoder G12.xy [mm]	L+brake with opt. encoder G12.xy [mm]	L with opt. encoder G6.1x [mm]	L+brake with opt. encoder G6.1x [mm]
LSH-050-1-30-48	67	105	130.5	168.5	In preparation	In preparation
LSH-050-2-30-48	82	120	145.5	183.5	In preparation	In preparation
LSH-050-3-30-48	97	135	160.5	198.5	In preparation	In preparation

Motor type	L with opt. encoder G6.2x [mm]	L+brake with opt. encoder G6.2x [mm]	L with opt. encoder G6.3x [mm]	L+brake with opt. encoder G6.3x [mm]	L with opt. encoder G3/G5 [mm]	L+brake with opt. encoder G3/G5 [mm]
LSH-050-1-30-48	98	133	In preparation	In preparation	106.5	144.5
LSH-050-2-30-48	113	148	In preparation	In preparation	121.5	159.5
LSH-050-3-30-48	128	163	In preparation	In preparation	136.5	174.5

Table: Overview of motor lengths – for overview of encoder types see section 5.1

Technical data <sup>1)</sup>	Symbol	LSH-050-1-30-48	LSH-050-2-30-48	LSH-050-3-30-48
Rated speed	$n_n$	3000 rpm	3000 rpm	3000 rpm
Rated frequency	$f_N$	150 Hz	150 Hz	150 Hz
DC link voltage (controller)	$U_{dc}$	48 V	48 V	48 V
Rated voltage	$U_n$	30 V	30 V	30 V
Rated torque	$M_n$	0.25 Nm	0.49 Nm	0.70 Nm
Rated current	$I_n$	3.2 A	5.6 A	7.3 A
Rated power	P	0.078 kW	0.154 kW	0.220 kW
Stall torque	$M_0$	0.26 Nm	0.53 Nm	0.74 Nm
Stall current	$I_0$	3.1 A	5.8 A	7.5 A
Maximum permissible torque	$M_{max}$	1.0 Nm	2.0 Nm	2.8 Nm
Maximum permissible current	$I_{max}$	13.0 A	24.0 A	31.0 A
Maximum permissible speed	$n_{max}$	12000 rpm	12000 rpm	12000 rpm
Voltage constant	$K_E$	5.0 V/1000 rpm	5.5 V/1000 rpm	6.0 V/1000 rpm
Torque constant	$K_T$	0.08 Nm/A	0.09 Nm/A	0.10 Nm/A
Winding resistance (2 phases)	$R_{2ph}$	1.83 $\Omega$	0.83 $\Omega$	0.6 $\Omega$
Winding inductance (2 phases)	$L_{2ph}$	3.10 mH	1.70 mH	1.32 mH
No load speed	$n_0$	5910 rpm	5400 rpm	5010 rpm
Electrical time constant	$T_{el}$	1.7 ms	2.0 ms	2.2 ms
Thermal time constant	$T_{th}$	13 min.	15 min.	20 min.
Moment of inertia of the motor	J	0.000006 kgm <sup>2</sup>	0.000008 kgm <sup>2</sup>	0.00001 kgm <sup>2</sup>
Mass	m	0.75 kg	0.92 kg	1.09 kg

#### Brake (optional)

Rated voltage	$U_N$	24 V $\pm$ 10 %
Rated current at 20 °C for venting	$I_N$	0.46 A
Permissible maximum speed	$n_{max}$	10000 rpm
Permissible friction energy	$W_R$	0.41 x 10 <sup>6</sup> Ws
Mass moment of inertia	$J_B$	0.000007 kgm <sup>2</sup>
Mass	m	0.15 kg
Braking torque	$M_H$	2 Nm

1) All values with a tolerance of  $\pm$  10%.

## 4.24.2 Characteristics

Explanations of characteristics:

The characteristic  $M_{\max}$  describes the maximum possible short-time torque at corresponding speed. It is important for dynamic processes.

The characteristic  $M_n$  indicates the thermally permissible rated torque.

The characteristics are limited by the respective maximum permissible speed  $n_{\max}$  (for  $n_{\max}$  refer to the "Technical data" table).



**NOTE:** LSH servomotors for functional extra-low voltage can optionally be run with 24 V or 48 V DC link voltage.

### LSH-050-1-30-48

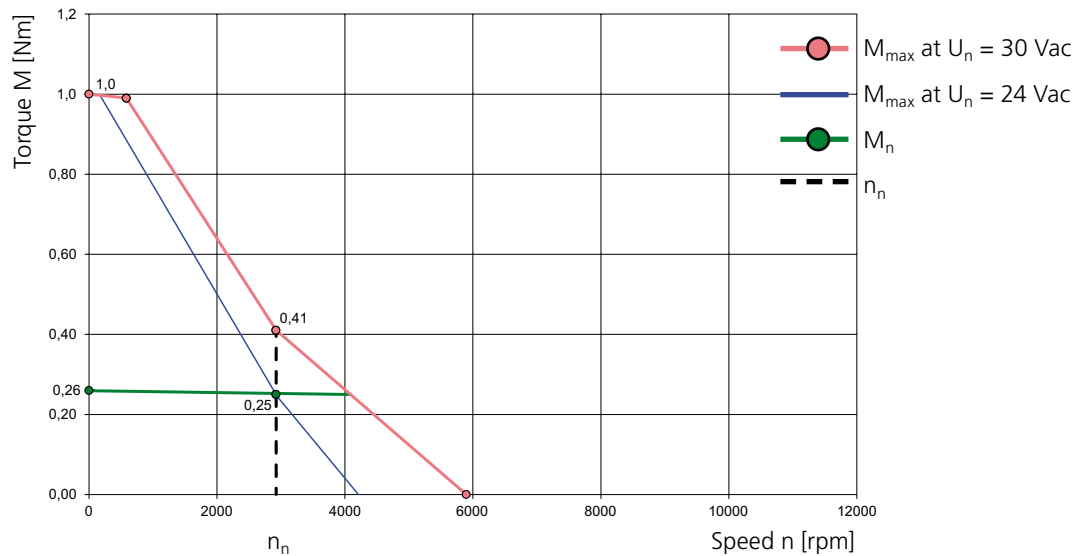

### LSH-050-2-30-48

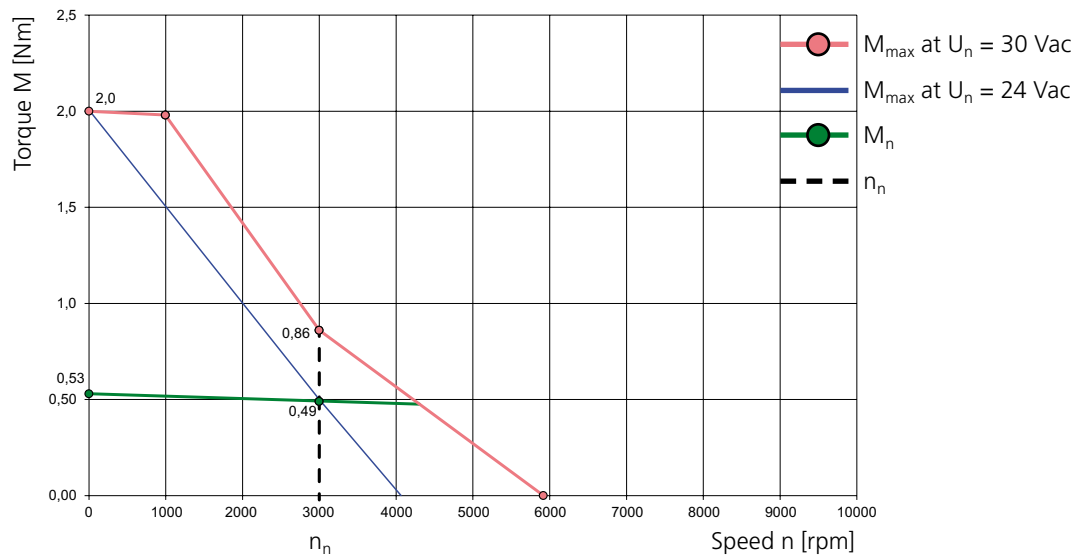



# LSH-050-3-30-48

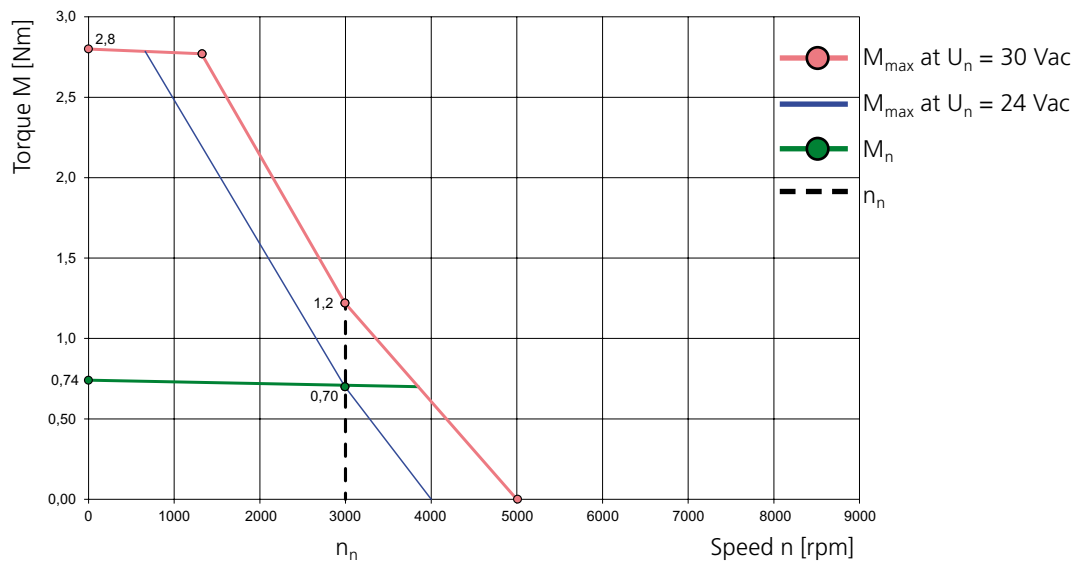

4.25 Motor type:  
LSH-074  
( $U_{dc} = 24\text{ V}/48\text{ V}$ )



4.25.1 Dimensional sketch and technical data

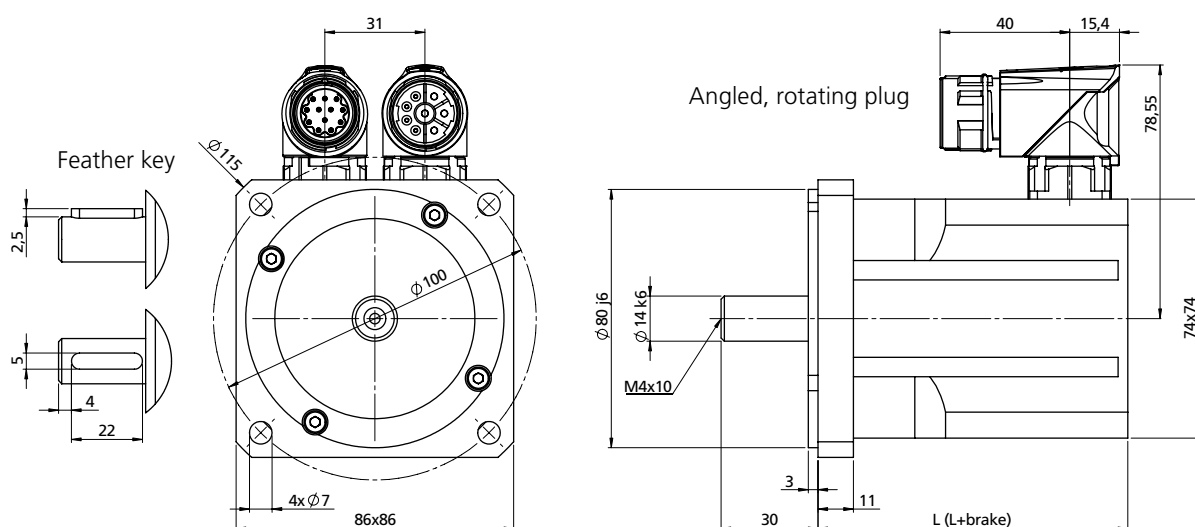

LST servomotors can optionally be run with 24 V or 48 V DC link voltage.

Motor type	L with resolver xR [mm]	L+brake with resolver xR [mm]	L with opt. encoder G12.xy [mm]	L+brake with opt. encoder G12.xy [mm]	L with opt. encoder G6.1x [mm]	L+brake with opt. encoder G6.1x [mm]
LSH-074-1-15-24	96	138	137	179	115.5	157.5
LSH-074-1-20-48	96	138	137	179	115.5	157.5

Motor type	L with opt. encoder G6.2x [mm]	L+brake with opt. encoder G6.2x [mm]	L with opt. encoder G6.3x [mm]	L+brake with opt. encoder G6.3x [mm]	L with opt. encoder G3/G5 [mm]	L+brake with opt. encoder G3/G5 [mm]
LSH-074-1-15-24	113	155	In preparation	In preparation	126	168
LSH-074-1-20-48	113	155	In preparation	In preparation	126	168

Table: Overview of motor lengths – for overview of encoder types see section 5.1

Technical data <sup>1)</sup>	Symbol	LSH-074-1-15-24	LSH-074-1-20-48
Rated speed	$n_n$	1500 rpm	2000 rpm
Rated frequency	$f_N$	125 Hz	166.7 Hz
DC link voltage (controller)	$U_{dc}$	24 V	48 V
Rated voltage	$U_n$	15 V	30 V
Rated torque	$M_n$	0.91 Nm	0.90 Nm
Rated current	$I_n$	10.6 A	7.6 A
Rated power	$P$	0.14 kW	0.18 kW
Stall torque	$M_0$	0.95 Nm	0.95 Nm
Stall current	$I_0$	10.5 A	7.6 A
Maximum permissible torque	$M_{max}$	2.4 Nm	2.4 Nm
Maximum permissible current	$I_{max}$	39 A	28 A
Maximum permissible speed	$n_{max}$	12000 rpm	12000 rpm
Voltage constant	$K_E$	5.5 V/1000 rpm	7.6 V/1000 rpm
Torque constant	$K_T$	0.09 Nm/A	0.13 Nm/A
Winding resistance (2 phases)	$R_{2ph}$	0.20 $\Omega$	0.39 $\Omega$
Winding inductance (2 phases)	$L_{2ph}$	0.60 mH	1.10 mH
No load speed	$n_0$	2720 rpm	3930 rpm
Electrical time constant	$T_{el}$	3.0 ms	2.8 ms
Thermal time constant	$T_{th}$	25 min.	25 min.
Moment of inertia of the motor	$J$	0.00005 kgm <sup>2</sup>	0.00005 kgm <sup>2</sup>
Mass	$m$	1.52 kg	1.52 kg

#### Brake (optional)

Rated voltage	$U_N$	24 V $\pm$ 10 %
Rated current at 20 °C for venting	$I_N$	0.5 A
Permissible maximum speed	$n_{max}$	10000 rpm
Permissible friction energy	$W_R$	0.58 x 10 <sup>6</sup> Ws
Mass moment of inertia	$J_B$	0.000018 kgm <sup>2</sup>
Mass	$m$	0.3 kg
Braking torque	$M_H$	4.5 Nm

1) All values with a tolerance of  $\pm$  10%.

## 4.25.2 Characteristics

Explanations of characteristics:

The characteristic  $M_{\max}$  describes the maximum possible short-time torque at corresponding speed. It is important for dynamic processes.

The characteristic  $M_n$  indicates the thermally permissible rated torque.

The characteristics are limited by the respective maximum permissible speed  $n_{\max}$  (for  $n_{\max}$  refer to the "Technical data" table).



**NOTE:** LSH servomotors for functional extra-low voltage can optionally be run with 24 V or 48 V DC link voltage.

### LSH-074-1-15-24

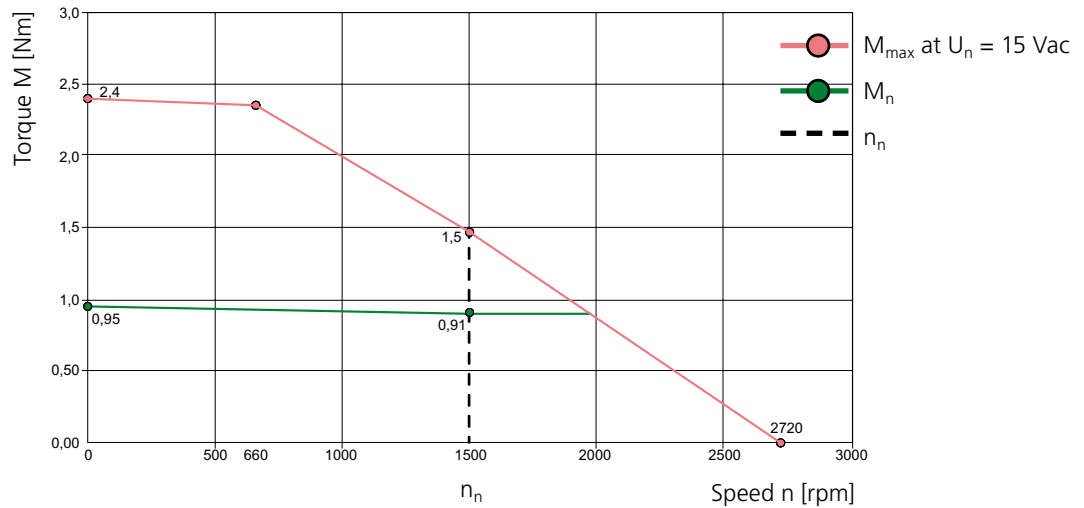

### LSH-074-1-20-48

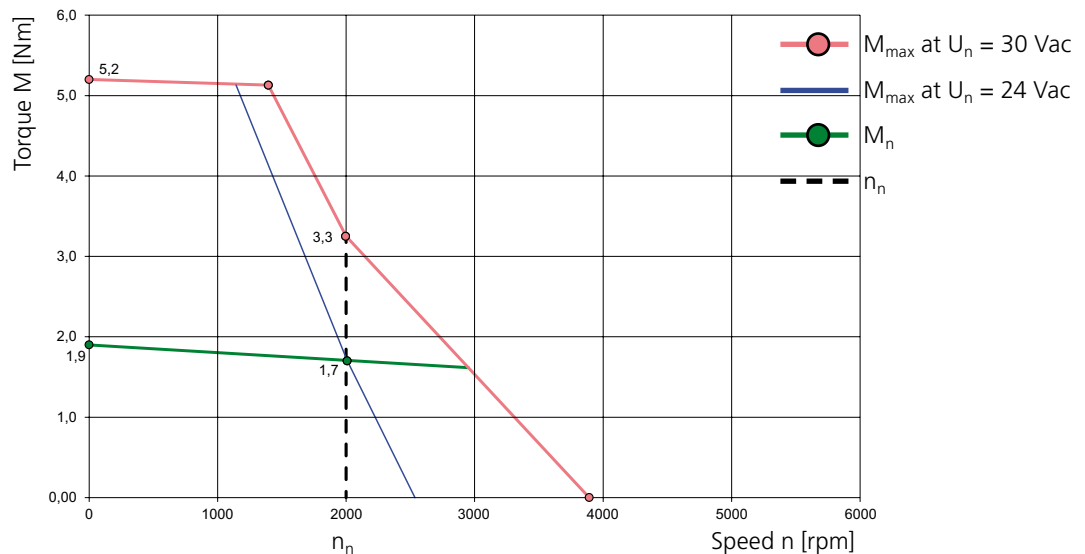

Space for notes

A large, empty grid of small squares, intended for taking notes. The grid is composed of 20 columns and 30 rows of squares.

Space for notes

A large grid of graph paper for taking notes, consisting of 20 columns and 30 rows of small squares.

# 5 Servomotor encoders

## 5.1 Overview of encoder types

Ordering option	Encoder designation	Compatible with								Encoder property		System property		
	Description	sin/cos periods/revolution	LSN-050	LSN-074 to LSN-190	LST 037	LST-050	LST 074 to LST-220	LSH-050	LSH-074 to LSH-127	Typ. absolute accuracy Encoder (encoder manufacturer's data sheet)	Typ. encoder repeat accuracy (encoder manufacturer's data sheet)	ServoOne position resolution for positioning Speed control	c-line position resolution for positioning control	c-line position resolution for speed control
1R	Resolver with 1 pole pair	1	X	X	X	X	X	X	X	+/- 10'	+/- 1'	14-bit +/-1'	14-bit +/-1'	14-bit +/-1'
1RY <sup>2)</sup>	Resolver with 1 pole pair Safety	1	X	X	X	X	X	X	X	+/- 10'	+/- 1'	14-bit +/-1'	14-bit +/-1'	14-bit +/-1'
3R	Resolver with 3 pole pairs	3	X			X	X	X		+/- 5'	+/- 1'	3x14 bit +/- 0.3'	3x14 bit +/- 0.3'	3x14 bit +/- 0.3'
5R	Resolver with 5 pole pairs	5		X					X	+/- 5'	+/- 1'	5x14 bit +/- 0.2'	5x14 bit +/- 0.2'	5x14 bit +/- 0.2'
G3	Multi-turn absolute value encoder EQN 1325 SSI	2048		X			X		X	+/- 20"	+/- 6"	25-bit +/- 0.04"	16-bit (CDD)	25-bit +/- 0.04"
G5	Single-turn absolute value encoder ECN 1313 SSI	2048		X			X		X	+/- 20"	+/- 6"	25-bit +/- 0.04"	16-bit (CDD)	25-bit +/- 0.04"
G6.1S <sup>1)</sup>	Single-turn absolute value encoder SRS 50	1024		X			X		X	+/-45"	+/- 7"	24-bit +/- 0.08"	16-bit (CDD)	24-bit +/- 0.08"
G6.1M <sup>1)</sup>	Multi-turn absolute value encoder SRM 50	1024		X			X		X	+/-45"	+/- 7"	24-bit +/- 0.08"	16-bit (CDD)	24-bit +/- 0.08"
G6.2S <sup>1)</sup>	Single-turn absolute value encoder SKS 36	128	X	X		X	X	X	X	+/- 80"	+/- 40"	21-bit +/- 0.6"	16-bit (CDD)	21-bit +/- 0.6"
G6.2SY <sup>1) 2)</sup>	Single-turn absolute value encoder SKS 36 Safety	128	X	X		X	X	X	X	+/- 80"	+/- 40"	21-bit +/- 0.6"	16-bit (CDD)	21-bit +/- 0.6"
G6.2M <sup>1)</sup>	Multi-turn absolute value encoder SKM 36	128	X	X		X	X	X	X	+/- 80"	+/- 40"	21-bit +/- 0.6"	16-bit (CDD)	21-bit +/- 0.6"

Table: 1) Not usable on CDF3000

Table: 2) Suitable for safety applications to EN 62061 and IEC 61508 and to EN ISO 13849-1

Ordering option	Encoder designation		Compatible with							Encoder property		System property		
	Description	sin/cos periods/revolution	LSN-050	LSN-074 to LSN-190	LST 037	LST-050	LST 074 to LST-220	LSH-050	LSH-074 to LSH-127	Typ. absolute accuracy Encoder (encoder manufacturer's data sheet)	Typ. encoder repeat accuracy (encoder manufacturer's data sheet)	ServoOne position resolution for positioning Speed control	c-line position resolution for positioning control	c-line position resolution for speed control
G6.2MY <sup>1) 2)</sup>	Multi-turn absolute value encoder SKM 36 Safety	128	X	X		X	X	X	X	+/- 80"	+/- 40"	21-bit +/- 0.6"	16-bit (CDD)	21-bit +/- 0.6"
G6.3S	Single-turn absolute value encoder SEK 37	16	X	X						+/- 288"	+/- 144"	18-bit	1)	1)
G6.3M	Multi-turn absolute value encoder SEL 37	16	X	X						+/- 288"	+/- 144"	18-bit	1)	1)
G12.1S <sup>1)</sup>	Single-turn absolute value encoder ECN 1313 Endat 2.1	2048		X			X		X	+/- 20"	+/- 6"	25-bit +/- 0.04"	16-bit (CDD)	25-bit +/- 0.04"
G12.1M <sup>1)</sup>	Multi-turn absolute value encoder EQN 1325 Endat 2.1	2048		X			X		X	+/- 20"	+/- 6"	25-bit +/- 0.04"	16-bit (CDD)	25-bit +/- 0.04"
G12.2S <sup>1)</sup>	Single-turn absolute value encoder ECN 1113 Endat 2.1	512	X			X		X		+/-60"	+/- 25"	23-bit +/-0.16"	16-bit (CDD)	23-bit +/-0.16"
G12.2M <sup>1)</sup>	Multi-turn absolute value encoder EQN 1125 Endat 2.1	512	X			X		X		+/-60"	+/- 25"	23-bit +/-0.16"	16-bit (CDD)	23-bit +/-0.16"

Table: 1) Not usable on CDF3000

Table: 2) Suitable for safety applications to EN 62061 and IEC 61508 and to EN ISO 13849-1



## 6 Servomotor accessories

### 6.1 Overview of encoder and motor cables

Cable types	Views	Types	Page
Encoder cables		KRY2-KSxxx KGS2-KSxxx KGH2-KSxxx KGH3-KSxxx KRY2-CDF-KSxxx	from 6-2
Motor cables		KM3-KSxxx-24A KM3-KSxxx-63A KM2-KSxxx KM3-KSxxx	from 6-4

Table: Overview of encoder and motor cables

## 6.2 Ready-made encoder cables

### 6.2.1 Order codes for encoder cables

K - RY2 - KS - 005	
<b>Ready-made cable</b>	
<b>Encoder system</b>	Resolver cable → <b>RY2</b> Encoder cable SSI, G3, G5, EnDat 2.1, G12.x → <b>GS2</b> Encoder cable Hiperface (G6.x) CDD3000 → <b>GH2</b> Encoder cable Hiperface (G6.x) ServoOne → <b>GH3</b>
<b>Festoon-compatible</b>	
<b>Cable length</b>	2 m → <b>002</b> 3 m → <b>003</b> 5 m → <b>005</b> 8 m → <b>008</b> 10 m → <b>010</b> 15 m → <b>015</b> 20 m → <b>020</b>

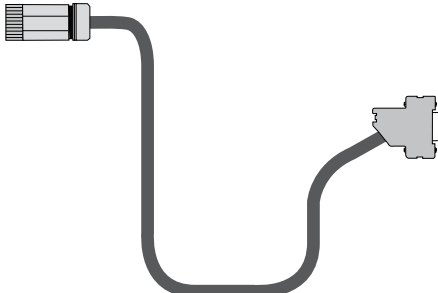
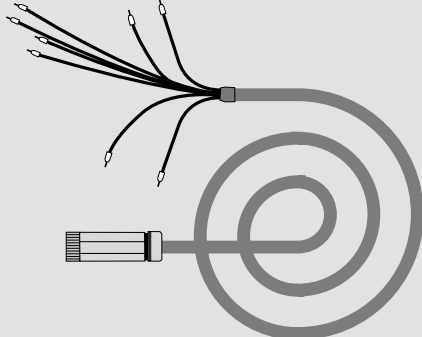
### 6.2.2 Technical data of encoder cables

	KRY2-KSxxx	KGS2-KSxxx
Controller type	CDD, CDE, ServoOne, ServoOne junior	CDD, CDE, ServoOne, ServoOne junior
Motors with encoder system	Resolver	G3, G5, G12.x (single/multi-turn encoder with SSI/Endat interface)
Controller-end assignment (sub-D connector)	1 = S2 2 = S4 3 = S1 4 = n.c. 5 = PTC+ 6 = R1 7 = R2 8 = S3 9 = PTC-	1 = A- 2 = A+ 3 = VCC (+5 V) 4 = DATA+ 5 = DATA 6 = B- 8 = GND 11 = B+ 12 = VCC (Sense) 13 = GND (Sense) 14 = CLK+ 15 = CLK- 7, 9, 10 = n.c.
Minimum bend radius	90 mm	100 mm
Temperature range:	in fixed installation	-35 ... +80 °C
	in flexible use	-40 ... +85 °C
Cable diameter approx.	8.8 mm	
Festoon-compatible	Yes	
Material of outer sheath	PUR	
Resistance	Resistant to oil, hydrolysis and microbic attack (VDE0472)	
Approvals	UL-Style 20233, 80 °C - 300 V, CSA-C22.2N.210 -M90, 75 °C - 300 V FT1	

Table: Technical data of encoder cables



	KGH2-KSxxx	KGH3-KSxxx	KGH4-KSxxx	KRY2-CDF-KSxxx
	CDD	ServoOne, ServoOne junior	ServoOne junior	CDF
	G6, G6.x (single/multi-turn encoder with Hiperface interface)			Resolver
	1 = REFCOS 2 = +COS 4 = DATA+ RS485 5 = DATA- RS485 6 = REFSIN 7 = U <sub>s</sub> 7-12 V 8 = GND 11 = +SIN 3, 9, 10, 12, 13, 14, 15 = n.c.	1 = REFCOS 2 = +COS 3 = U <sub>s</sub> 7-12 V 4 = Data+ RS485 5 = Data- RS485 6 = REFSIN 7 = Jumper to pin 12 8 = GND 11 = +SIN 12 = Jumper to pin 7 9, 10, 13, 14, 15 = n.c.	1 = REFCOS 2 = +COS 3 = U <sub>s</sub> 7-12 V 4 = Data+ RS485 5 = Data- RS485 6 = REFSIN 7 = Jumper to pin 12 8 = GND 9 = PTC- 10 = PTC+ 11 = +SIN 12 = Jumper to pin 7 13, 14, 15 = n.c.	1 = SIN- (S4) 2 = SIN+ (S2) 6 = COS- (S3) 7 = REF- (R2) 9 = PTC- 10 = PTC+ 11 = COS+ (S1) 12 = REF+ (R1) 3, 4, 5, 8, 13, 14, 15 = n.c.
	90 mm			
	-40 ... +85 °C	-40 ... +85 °C	-40 ... +85 °C	-40 ... +85 °C
	8.8 mm			
	Yes			
	PUR			
	Resistant to oil, hydrolysis and microbic attack (VDE0472)			
	UL-Style 20233, 80 °C - 300 V, CSA-C22.2N.210 -M90, 75 °C - 300 V FT1			

## 6.3 Ready-made motor cables

### 6.3.1 Order codes for motor cables

		KM2	-	KS	-	005	-	XXX
<b>Ready-made cable</b>		<i>C-Line</i> → <b>KM2</b>						
		<i>ServoOne</i> → <b>KM3</b>						
		<i>C-Line / ServoOne / ServoOne junior</i> → <b>KM4</b>						
		<i>ServoOne junior</i> → <b>KM5</b>						
<b>Festoon-compatible</b>								
<b>Cable length</b>		2 m → <b>002</b>						
		3 m → <b>003</b>						
		5 m → <b>005</b>						
		8 m → <b>008</b>						
		10 m → <b>010</b>						
		15 m → <b>015</b>						
		20 m → <b>020</b>						
<b>Motor cable</b>		to $I_0 = 16\text{ A}$ → -						
		to $I_0 = 24\text{ A}$ → <b>24 A</b>						
		to $I_0 = 63\text{ A}$ (only LSx-220) → <b>63 A</b>						

### 6.3.2 Technical data of motor cables

		KM2/3-KSxxx	KM3-KSxxx-24A
Motor type		Motors up to $I_0 = 16\text{ A}$ with plug-in power connection	Motors up to $I_0 = 24\text{ A}$ with plug-in power connection
Minimum bend radius:	in fixed installation	90 mm	115 mm
	in flexible use	120 mm	150 mm
Temperature range		-30 ... +80 °C	-30 ... +80 °C
Cable diameter approx.		ø 12 mm	ø 15 mm
Cable cross-section		4G1.5+ 2 x 2 x 0.75 mm <sup>2</sup>	4G2.5+ 2 x 2 x 1 mm <sup>2</sup>
Material of outer sheath		PUR	PUR
Resistance		Resistant to oil, hydrolysis and microbic attack (VDE 0472)	
Wiring		U = 1 V = 2 W = 3 Earth = ye/gn PTC = 5 PTC = 6 Brake + = 7 Brake - = 8	U = 1 V = 2 W = 3 Earth = ye/gn PTC = 5 PTC = 6 Brake + = 7 Brake - = 8
Approval		UL AWM 80 °C - 600 V/1000 rpm V; CSA AWM 80 °C - 600 V/1000 rpm V FT1	

Table: Technical data of motor cables



	KM3-KSxxx-63A	KM4	KM5
	Motors up to $I_o = 63$ A with plug-in power connection	Motors up to $I_o = 16$ A with plug-in power connection	Motors up to $I_o = 16$ A with plug-in power connection
	165 mm	65 mm	90 mm
	220 mm	85 mm	120 mm
	-30 ... +80 °C	-30 ... +80 °C	-30 ... +80 °C
	ø 22 mm	ø 8.5 mm	ø 12 mm
	4G10 + 2 x 1.5 mm <sup>2</sup> + 2 x 1 mm <sup>2</sup>	4G1.5	4G1.5+ 2 x 2 x 0.75 mm <sup>2</sup>
	PUR	PUR	PUR
Resistant to oil, hydrolysis and microbic attack (VDE 0472)			
	U = 1 V = 2 W = 3 Earth = ye/gn PTC = 5 PTC = 6 Brake + = 7 Brake - = 8	U = 1 V = 2 W = 3 Earth = ye/gn	U = 1 V = 2 W = 3 Earth = ye/gn PTC = 5 PTC = 6 Brake + = 7 Brake - = 8
UL AWM 80 °C - 600 V/1000 rpm V; CSA AWM 80 °C - 600 V/1000 rpm V FT1			

Space for notes

A large grid of graph paper for taking notes, consisting of 20 columns and 30 rows of small squares.

## 7 Appendix

### 7.1 Holding brake



The backlash-free, permanent-field single-disc holding brake works on the closed circuit principle, meaning that current needs to be applied to the brake to release it.

For optimum holding torque and lowest possible circumferential backlash, on all LSx motors the holding brake is attached directly behind the flange (on the drive side).

The holding brake is always activated and deactivated at standstill. When the holding brake is deployed as an emergency stop brake, you need to pay attention to the maximum permissible friction energy ( $W_R$ ).

**LTI DRIVES**

D-35633 Lahnau 8 5 5 1 6 5

Typ	LSN-127-1600-30-560/T1,B,P,S4,G6.3S			37/11
SN	855165	Art.Nr.	11779004	
$M_0$	16 Nm	$U_{dc}$	560 V	Iso.-Kl. F
$N_n$	3000 r/min	$I_n$	9,89 A	IP64

Made in EU

An LSP servomotor with holding brake is identifiable by the name plate.

Example:

**LSN-127-1600-30-560/T1,B,P,S4,G6.3S**



**NOTE:** When the holding brake is deployed as an emergency stop brake, the braking torque may be substantially lower than the holding torque.

#### 7.1.1 Holding brake response times

If DC-side switching takes place between the rectifier and coil, an extremely short run-on is attained. For drives requiring precise braking, in particular for lifting gear, DC-side switching of the brake is essential.

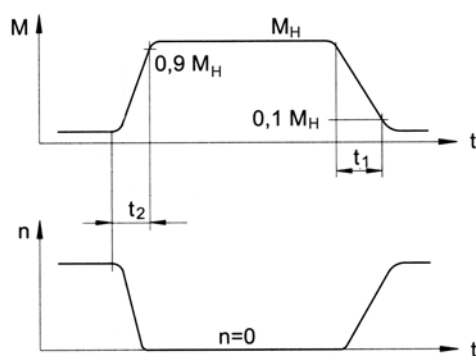

Letter	Meaning
M	Braking torque
$M_H$	Holding torque of spring-operated brake
N	Speed
t	Time
$t_1$	Switch-on time
$t_2$	Switch-off time

## 7.1.2 Technical data of holding brake

Letter	Meaning
$t_1$	Switch-on time
$t_2$	Switch-off time
$M_H$	Holding torque, or adhesion torque, of spring-operated brake (break-away torque)
$I_N$	Excitation current at 20° C for venting
$U_N$	DC voltage for venting

Letter	Meaning
$n_{max}$	Maximum speed (unbraked)
$m$	Mass (weight)
$W_R$	Permissible friction energy up to 0.1 mm abrasion (for emergency stop)
$J_B$	Moment of inertia of holding brake

Size	$t_1$ [ms]	$t_2$ [ms]	$M_H$ [Nm]	$I_N$ [A] at 24 V	$U_N$ [V]	$n_{max}$ [rpm]	$m$ [kg]	$W_R$ [10 <sup>6</sup> Ws]	$J_B$ [kgcm <sup>2</sup> ]
LST-037	6	10	0.4	0.33	24 V ± 10 %	10.000	0.075	0.20	0.013
LSx-050	6	25	2.0	0.46	24 V ± 10 %	10.000	0.15	0.41	0.07
LSx-074	7	35	4.5	0.5	24 V ± 10 %	10.000	0.3	0.58	0.18
LSx-097	7	40	9.0	0.75	24 V ± 10 %	10.000	0.82	0.89	0.54
LSx-127	10	50	18.0	1.0	24 V ± 10 %	10.000	1.8	1.29	1.66
LSx-158	22	90	36	1.1	24 V ± 10 %	10.000	2.85	2.90	5.56
LSx-190	22	90	36	1.1	24 V ± 10 %	8.000	3.25	2.9	6.2
LST-220	65	105	145	2.1	24 V ± 10 %	8.000	9.5	13	56

Table: Technical data of holding brake



**NOTE:** The values  $m$  and  $J_B$  are purely brake data values. They take no account of the mass and moment of inertia of the motor shaft.

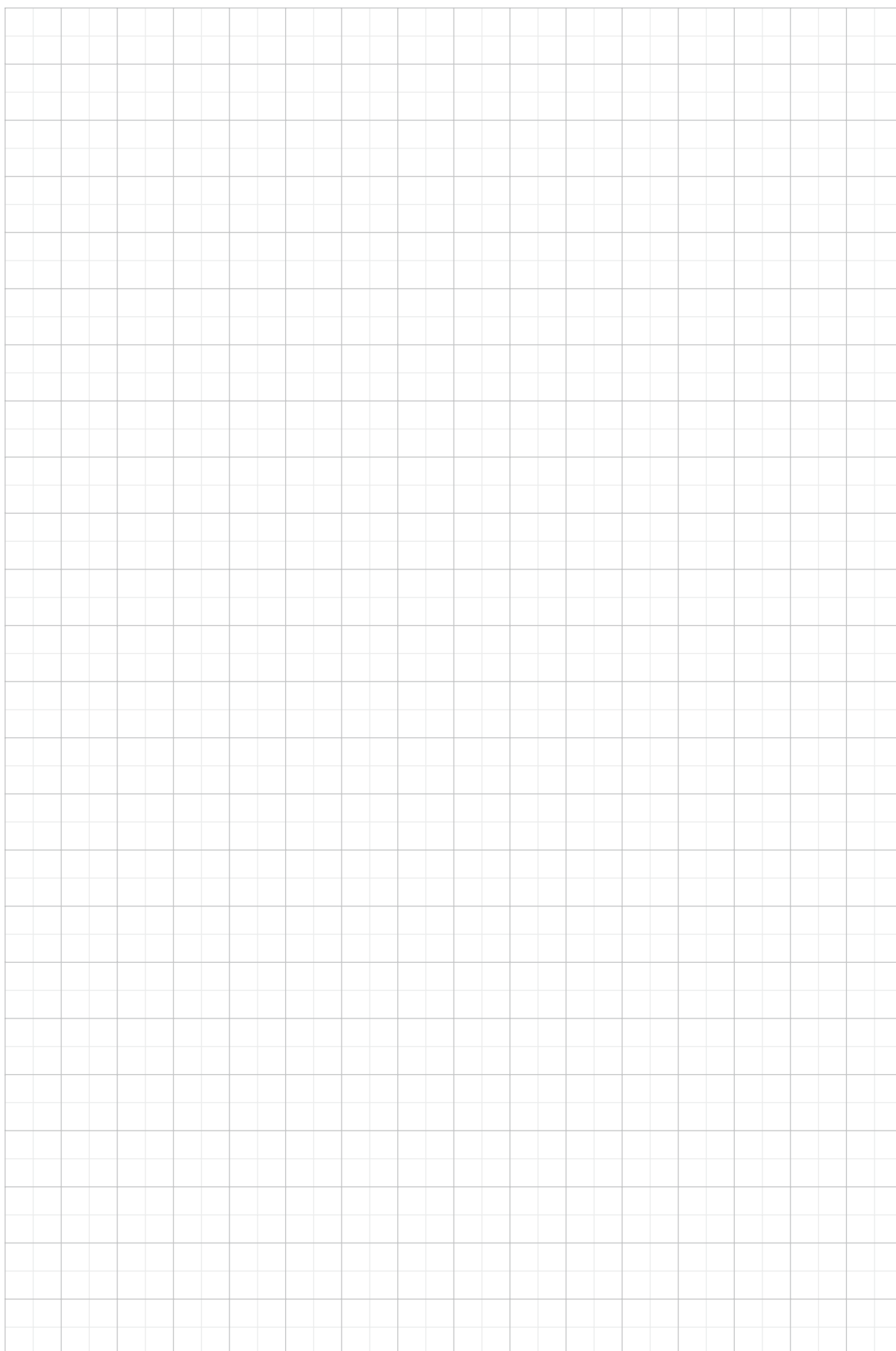

Space for notes

A large, empty grid of small squares, intended for taking notes. The grid is composed of 20 columns and 30 rows of squares.

Space for notes

A large grid of graph paper for taking notes, consisting of 20 columns and 30 rows of small squares.





**LTI DRIVES GmbH**

Gewerbestraße 5-9  
35633 Lahnau  
Germany  
Phone +49 (0) 6441 / 966-0

Heinrich-Hertz-Straße 18  
59423 Unna  
Germany  
Phone +49 (0) 2303 / 779-0

[www.lt-i.com](http://www.lt-i.com)  
[info@lt-i.com](mailto:info@lt-i.com)

**Subject to technical change  
without notice.**

*The content of our Order Catalogue was compiled with the greatest care and attention, and based on the latest information available to us.*

*We should nevertheless point out that this document cannot always be updated in line with ongoing technical developments in our products.*

*Information and specifications may be subject to change at any time. For information on the latest version please visit <http://drives.lt-i.com>.*

*The German version is the original of this Order Catalogue.*

Order Catalogue: LSx Servomotors

ID no.: 0814.258.6-01 Date: 07/2014